



DRAGONSKIN

The coatings for
the highest performance

For more information:



cutting.tools/en/dragonskin

TEAM CUTTING TOOLS



CERATIZIT is a high-technology engineering group specialised in cutting tools and hard material solutions.

Tooling the Future

www.ceratizit.com

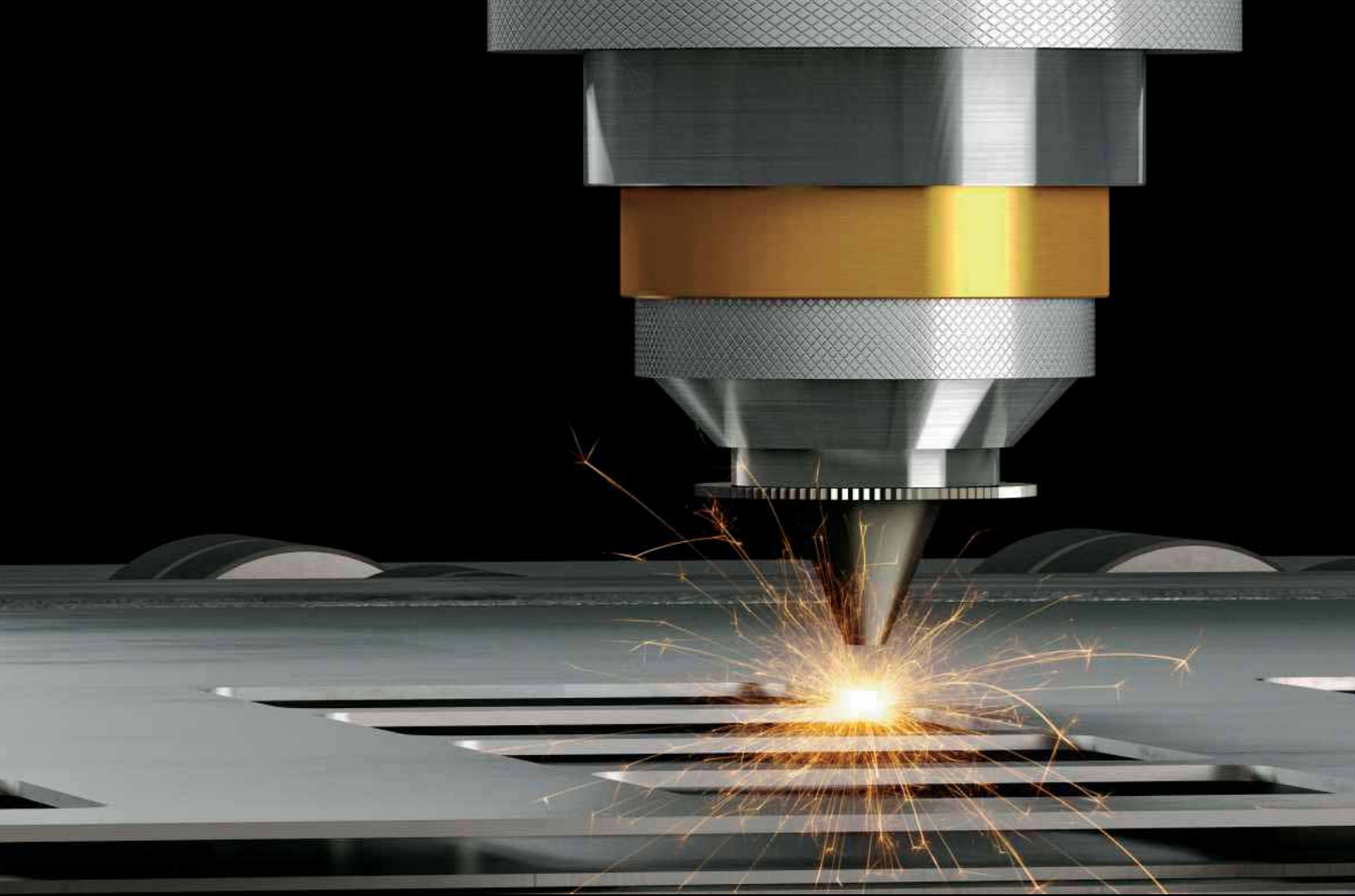

TECHNOLOGY MEETS EFFICIENCY

CAD/CAM | MES | ERP+ | ADVANCED MANUFACTURING

lantek

www.lantek.com

Visit our website at:
www.engineeringsubcontractor.com

CONTENTS

NEWS	4
FEATURE - 5-AXIS MACHINING	10
METAL CUTTING	12
FEATURE - LUBRICATION	16
MACHINE SAFETY	20
FEATURE - CUTTING TOOLS	22
WORKHOLDING	30
FEATURE - ADVANCED MANUFACTURING	34
CADCAM	38
FEATURE - METAL MARKING	44
MEASUREMENT & INSPECTION	48
FEATURE - SAWING & CUTTING OFF	50
METAL FORMING	54

NEXT ISSUE NOVEMBER

- MEDICAL REPORT
 - CAD/CAM
- DEEP HOLE DRILLING
 - EDM
- LASER CUTTING
 - WELDING

Published by Roger Barber Publishing
Enterprise House, Foundry Lane, Horsham, West Sussex, RH13 5PX
Tel: 01403 266022

Publisher: Roger Barber
Email: roger@rbpublishing.co.uk

Editor: John Barber - 01403 266022
Email: john@rbpublishing.co.uk

Accounts: Jackie Barber - 01403 563791

Production manager: Anna Rodrigues - 01472 210712
Email: studio@rbpublishing.co.uk

Design & Production: Roger Barber Publishing
Print: Holbrooks Printers Ltd, Portsmouth, Hampshire

Engineering Subcontractor is mailed to a controlled circulation of readers with a legitimate interest in the content. Roger Barber Publishing stores all business data securely and does not share with third parties.

No part of this publication may be reproduced without express written permission.

Machining without compromise

Within the engineering subcontract world, the pressure to deliver high quality components in ever reducing lead times continues to rise. It is here that Ceratizit has focused its efforts to help meet that challenge. The result was Dragonskin. This innovative coating technology revolutionised metalcutting and continues to do so. The latest development sees two new turning grades introduced CTCM120 and CTCM130, both featuring Dragonskin coatings.



Dragonskin coatings provide the highest degree of protection by creating an almost impenetrable protective layer which, when combined with Ceratizit's high-performance carbide substrates, allows users to increase cutting data without compromising tool life. In fact, when compared to previous grades, tool life can see a 50 percent increase.

With the development of the two new grades, which sit either side of the universal grade CTPM125, Ceratizit has ensured that customers have the right solution for their specific turning requirements. CTPM120, with a choice of five chipbreaker styles, is ideal for the machining of Austenitic steels, where high cutting speeds are required, along with a smooth cutting action. In tests, machining nickel chrome alloy at a surface speed of 160 m/min, 0.35 mm/rev feed and depth of cut between 1 and 3 mm, tool life was extended by 50 percent. CTCM 130 comes into focus where cutting conditions may be more arduous, with interrupted cuts, where lower cutting speeds are required. This extremely tough grade provided optimum process security, which helps to reduce manufacturing costs by eliminating unnecessary tool changes and also reducing potential scrap rates.

With the addition of these two new insert grades, Ceratizit has created the complete turning solution for austenitic stainless-steel materials, with the combination of insert grades, chipbreaker styles and the choice of positive and negative geometries. At the heart of their success, though, lies Ceratizit's Dragonskin coating. You can be assured that if the insert you choose has a Dragonskin coating, you are guaranteed unmatched metal cutting performance, maximum tool life and reassurance of optimum process security.

CERATIZIT UK & IRELAND Ltd
Tel: 0800 073 2073
Email: tony.pennington@ceratizit.com
www.ceratizit.com

Exciting new appointment at KUKA UK

KUKA is one of the world market leaders in rotational friction welding. The iconic Thompson friction welding machines are custom built by KUKA at their Halesowen facility, in the heart of the Black Country, UK.

As a solid-state joining process, rotational friction welding has been adopted across the manufacturing arena within the automotive, oil and gas and electrical power distribution sectors, to name but a few, and continues to be favoured by manufacturers because of its high structural integrity.

Stepping into the role of business unit manager of Advanced Welding Solutions and coordinating KUKA's AWS growth strategy is Steve Malone, an accomplished sales manager with a proven track record of developing and delivering sales strategies for companies with high growth ambitions, in both UK and international markets.

Steve Malone says: "KUKA is a truly international brand. Companies I have been associated with throughout my career all delivered the very best manufacturing, robotic and material handling solutions to some of the most demanding customers, in even more demanding sectors and these familiar expectations presented to me at every stage of the interview process fed my desire to join KUKA. I crave success for those I represent and still have the ambitions and aspirations of a 25-year-old. KUKA's

strategy is one of growth which fits my remit of growth delivers success."

He will be tasked with several objectives within his new role, as KUKA aim to increase market share across a broader range of industry sectors, as part of a strategy to be 'smarter' in realising where opportunities exist.

Steve Malone continues: "The Thompson product has unique strengths in delivering exactly what our customers want. We need to exploit this to the maximum, to the benefit of us all. KUKA can develop within the welding market, but also has the opportunity to develop Thompson products for this market so let's innovate and thrive."

Describing himself as 'ambitious, willing, and aware', Steve Malone is a married father of two grown up sons. "I love life, I love football," being Liverpool-based, he is used to seeing his team achieve and succeed.

KUKA UK & Ireland CEO Jeff Nowill says: "I am confident that Steve will help to drive the friction welding business forward. He has a proven background in machine tools with international groups such as KUKA and a sound understanding of manufacturing principles. He brings an enthusiasm and professionalism to his position that will be a huge bonus to the business, even if he is alarmingly misguided with regards to the relative merits of rugby and football!"

He will also have a part to play in the management of the subcontract friction welding provision that is a speciality at KUKA's Halesowen site. Efficient in handling small scale and high-volume production runs, KUKA's in-house Thompson machines are configured to join a wide variety of materials including dissimilar materials and components for many different applications.

Working closely with Rainer Kiesswetter, vice president of business unit for Advanced Welding Solutions, KUKA AG, Steve Malone will ensure that KUKA's local and international strategies are also aligned.

KUKA Systems UK is the British manufacturer of Thompson rotary and linear friction welding machines. The company has produced over 700 machines in the past 50 years and has been one of the pioneers in the development of friction welding.

To find out more about KUKA's advanced welding solutions, or the Thompson range of friction welding machines, contact:

KUKA Systems UK
Tel: 0121 5850888
Email: steve.malone@kuka.com
www.kuka.com



Mazak unveils new remote CNC training program for UK customers

Yamazaki Mazak has expanded its CNC training program to include remote sessions at customer sites, enabling both new and existing customers to unlock the benefits of MAZATROL Smooth CNC while social distancing remains in place.



The remote training program involves Mazak delivering two full-size CNC control panel simulators and accompanying training material to a customer's site

and then running a series of live interactive tutorials over the following days via Microsoft Teams. The simulators are then collected, cleaned and delivered to the next booking.

The new format will complement the company's long-standing 'in person' training sessions at its recently reopened Training Academy in Worcester, which will continue to take place under new social distancing guidelines.

Mazak has a number of simulators for each of its MAZATROL Smooth CNC variants. These include its newest CNC, SmoothAi, which ensures the perfect harmonisation of CNC and machine to deliver faster programming, high-speed material removal and increased accuracy for machine users; as well as SmoothX, SmoothG and SmoothC.

Graham Rash, UK project engineering & applications manager at Yamazaki Mazak, comments: "CNC training is a fundamental part of our aftersales and support offering for both new and long-standing customers alike. Our courses have always been popular, especially with those who have purchased their first Mazak machine and are using MAZATROL Smooth CNC for the first time. However, the current social distancing guidelines have led to a re-think as to how to deliver them in a safe and effective way.

"The use of simulators which are identical to the actual control panel used on our machine tools are critical to the training experience offered, so physically delivering them to our customers was a logical and quite straightforward process. What's more, as the training groups are now much smaller, it has enabled us to really tailor the sessions to each individual customer's requirements, to offer a truly bespoke learning experience."

Eric Saunder, subcontract operations manager at Mollart Engineering recently booked a remote training session for a number of the company's engineers: "The team really enjoyed the experience and gained a lot from the session. Sending the simulators to our site was a fantastic solution during these uncertain times and it also really helped with our structured apprentice programme."

Yamazaki Mazak UK Ltd
Tel: 01905 755755
Email: sales@mazak.co.uk
www.mazakeu.co.uk



BE IN CONTROL AND SAVE





30%*

PROCUREMENT SAVINGS

- FULL VISIBILITY & CONTROL
- CONSIGNED STOCK*
- REPORTING
- INCREASED PRODUCTIVITY
- FILLING SERVICE
- 30% SAVINGS*
- 24/7 AVAILABILITY

*Savings and consigned stock are all subject to individual agreement

INTELLIGENT INVENTORY MANAGEMENT SOLUTIONS

With automated replenishment you reduce time raising purchase orders and managing your suppliers. Our solutions also give you full transparency over inventory cost and usage in addition to lowering your inventory levels.

Tel: 0121 716 4301

Email: ab.uk@hoffmann-group.com

www.hoffmann-group.com

Denis Welch Motorsport invests in Haas to further success on and off track

Motor racing is in the blood for Jeremy Welch. His great grandfather built the first six-cylinder engine ever made in the UK in 1906 and went on to build Brook Marine racing engines with notable success, world champion in 1921. Jeremy's father founded Denis Welch Motorsport over 40 years ago and it has had notable success in the UK, Europe, Australia and the Far East.

When building cars it became obvious that older cars needed new components, as the originals were no longer available. They supply replacement performance parts for classic cars as well as restoring and preparing ex-works cars and specialise in Jaguar E-type and Austin Healey.

Building a business from drawings to quality production

Jeremy Welch took over the business 15 years ago and is now sole owner. He began working at the company as a teenager, restoring the works 1965 Lemans Sprite and has never lost his passion for racing. He personally drove the Healey Endurance car along with the owner, which set 17 national, and international speed records and still holds the UK record for the fastest vehicle over a 100-mile distance in the UK.

When he took over, there were no CNC machines to develop the parts manufacturing side of the business, so he set about acquiring access to original drawings then converting them to modern CAD/CAM programmes. Quality and supply security were also important. In the old days manufacturing was subcontracted out, which meant that new designs were shared with third parties, and quality sometimes varied. Jeremy Welch found that skilled work on castings was being turned down by subcontractors, so he turned to Haas who,



working with the CAD/CAM software suppliers, delivered the perfect solution for CNC porting their cylinder heads on a Haas HMC horizontal machining centre.

Its in-house design and manufacturing facility has over £1,500,000 of parts on the shelf these days. Two thirds of its turnover is global mail order to trade and private customers.

Denis Welch Motorsport still prepares race cars, ensuring they are track-ready and transported to the circuit. One recent restoration project was the ex Andy Rouse 1989 Ford Sierra Cosworth RS 500. Many parts on this age of car are simply no longer available, so they are produced on the Haas machines.

Latest developments

Three Haas lathes, a UMC-750 5-axis universal machining centre and a VF-4SS super speed vertical machine have been added in the last few years.

Jeremy Welch says: "We did look around the market, but nothing rivalled Haas. We felt comfortable investing because we know what we're going to get, a great product, together with a reliable management and service team. The whole package works for us.

"Having our manufacturing in-house has

made a massive difference. We've expanded our range considerably and we can now control our own processes and quality. We have much better flexibility too; if a race car has an issue at the eleventh hour, we simply remake the part. We're taking control of our own destiny.

"The training has been tremendous. I'd never written a program, but with Haas' help I jumped straight on the 5-axis machine. We do mainly 3 + 2 machining which enables us to use less fixturing and most programming is completed manually at the control using the Haas G254 Dynamic Work Offset function. One of our operators had never used a CNC, but after training with Haas he now writes programs on the ST-25Y lathe using Y-axis and live tooling."

The latest acquisition is an ST40 turning centre, which is currently machining period magnesium wheels and uprights for race Jaguars.

Jeremy Welch concludes: "We bought the machine especially for this job and it's been fantastic. I recommend Haas to anyone I can."

Haas Automation Ltd
Tel: 01603 760539
Email: cnc@haas.co.uk
www.haas.co.uk



Mazak

Your Partner for Innovation



QUICK TURN
250M



VCN-430A



CV5-500



VTC-760C



VTC-800/30SR



BEST OF BRITISH MANUFACTURING



www.mazakeu.co.uk

DISCOVER MORE WITH MAZAK™

New Doosan 5-axis machine tool investment pays dividends

Significantly reduced machining operations leading to reduced part cycle times, improved operational efficiencies and new business wins are just some of the benefits Baker Engineering is experiencing from its latest Doosan 5-axis machine tool investment.

Mills CNC, the exclusive distributor of Doosan machine tools in the UK and Ireland, has recently supplied Baker Engineering Ltd, a leading precision toolmaker and engineering subcontract specialist based in Derby, with a new, high-performance Doosan DVF 5000 5-axis machining centre.

The machine was installed at the company's new, purpose-built 8,000 sq ft facility in April 2020 and is being used to machine a diverse range of high-precision components, as well as specialist tooling, jigs and fixtures for its growing UK and international customer base.

The DVF 5000 is the second Doosan machine tool Baker Engineering has invested in recently, the first being a new DNM 6700 vertical machining centre which was acquired in February 2017.

5-axis machine tool investment

Baker Engineering is a family-owned business established in 2008 that today employs 15 members of staff.

The company is ISO 9001: 2015 accredited and is committed to continuous improvement making regular investment in the latest machine tool and ancillary manufacturing technologies to maintain its competitiveness and strengthen its preferred partner relationships with its customers.

Baker Engineering has a number of CNC machines at its disposal, including machining centres with integrated 4th-axis units, lathes with bar feeders and wire EDM machines.



In addition to offering precision subcontract machining services the company also has specific strengths in manufacturing aerospace component tooling, for example jigs and fixtures for ground support maintenance, tooling for the measurement and inspection of railway tracks and tooling used in the power generation sector.

As a forward-thinking company, the decision to invest in the latest 5-axis machining technology was a natural one for Baker Engineering to make, having begun in earnest earlier in 2019.

Director Adrian Baker explains: "Multi-axis and multi-tasking machine tools help manufacturers improve their productivity. As we are a company that's looking to constantly improve, we had done our homework into the technology and could see that an investment in a 5-axis machine tool would deliver significant performance benefits.

"In addition, the investment would send the right signals, externally and internally, that Baker Engineering was focused on the future."

The key advantages from investing in 5-axis machine tool technology were immediately apparent to management and staff at the company and included the ability to machine complex shapes/parts in a single setup with the added benefit that 'one-hit'

machining has on reducing the time and costs involved in fixturing. The ability to improve/maintain part accuracies owing to a reduction in work handling was also important.

Adrian Baker explains: "Since the DVF 5000 machine's installation we have experienced all of these benefits."

A demonstration of the machine's capabilities and its impact on Baker Engineering's performance can be seen in the following example:

A custom electrical housing-type component was machined, prior to the arrival of the DVF 5000, in five separate machining operations with a cycle time of 2.5 hours. When machined on the DVF 5000 the number of operations was reduced to two and the cycle time was 0.75 hours.

Adrian Baker says: "The above is typical of the results we have been able to achieve since we invested in the machine."

Prior to making the 5-axis machine tool investment decision, Baker Engineering did its homework and investigated the market in order to help identify the type of machine that would 'fit the bill'.

He continues: "We had invested in a DNM 6700 vertical machining centre from Mills CNC in 2017. We have been pleased with the machine's performance and reliability and have been impressed with Mills' after-sales service and support.

"When considering the 5-axis machine tool investment, it was natural that we approached them to discuss our requirements." These discussions resulted in the DVF 5000 being recommended.



The DVF 5000

The Doosan DVF 5000, a popular and best-selling 5-axis machine from Mills CNC's impressive machine tool portfolio, is a compact and rigidly-built machine that delivers excellent cutting performance and unrivalled machining flexibility.

The machine offers full simultaneous 5-axis machining capability as well as 3 + 2 and 4 + 1 operation. Baker Engineering is predominantly using the machine for 3 + 2 and five-face machining.

The DVF 5000 features a powerful, direct-drive spindle, up to 18.5 kW/12,000 rpm, a generous-sized tool changer, up to 120 position, linear guides and a 500 mm x 450 mm work table with 400 kg table load.

The machine is fast boasting 40 m/min rapids and was supplied to Baker Engineering with a 60-position ATC, integrated tool measurement and the latest FANUC 0iMF control.

Since installation

The DVF 5000 has been fully operational at Baker Engineering's facility since the end of April 2020 and has been in constant use since then. As well as it helping the company increase its productivity and efficiency, the machine has also helped Baker Engineering win new machining work.

Adrian Baker concludes: "News travels fast. On hearing that we had invested in Doosan 5-axis machine tool technology, a new customer contacted us asking us to quote on a job. We have successfully turned the enquiry into an order.

"Our decision to invest in the Doosan DVF 5000 has been vindicated. The machine has significantly strengthened our machining capacity and capabilities. It is fast, accurate and reliable and represents great value."

Mills CNC Ltd

Tel: 01926 736736

Email: sales@millsnc.co.uk

www.millsnc.co.uk



WHITEHOUSE

ADVANCED | ENGINEERING | SOLUTIONS

EX DEMONSTRATION WELE UQ400 5 AXIS VERTICAL MACHINING CENTRE



Unique opportunity to acquire a high specification 5-Axis VMC at a very special price.

This Showroom Demo WELE UQ-400 machining centre has only been very lightly used and is in excellent condition - ex-stock and immediately available. The comprehensive standard specification is enhanced with Blum Spindle and Tool Probing.

Special Offer Price

Only on this particular machine... **£99,100**

Including delivery, siting and training.

KEY FEATURES

- New - Fanuc 0iMF Control
- 40 tool magazine with ATC arm
- 12000 rpm direct drive spindle
 - Motor power 18,5/15 kW
 - BBT40 Big Plus Spindle
- Coolant through spindle with standard tank 20 bar
 - LOSMA mist extraction system
 - Blum TC52 Spindle Probe & IR Tool Probe

See the UQ400 in action via :

WWW.WMTCNC.COM

Simultaneous turning capability on a 5-axis machining centre

GF Machining Solutions has introduced the Mikron MILL P 800 U ST machining centre, which integrates milling and turning in a single machine to its impressive machine tool portfolio.

Highly efficient, the compact machine provides 800 mm of X-axis travel, an 800 rpm C-axis rotation speed and a maximum table load of 800 kg.

The MILL P 800 U ST was designed with its gantry-type concept as a direct response to the needs of component manufacturers serving the automotive, aerospace, energy and general machining industries. The machine's small footprint makes it easy to integrate into facilities where space is at a premium and is able to replace two machines involved in a machining process.

The combination of milling and turning technology in a single machine helps manufacturers improve productivity, accuracy and cost-effectiveness. The MILL P 800 U ST achieves perfect workpiece roundness, superior surface finishes and high material removal rates. As such, according to Martin Spencer, GF Machining Solutions UK's managing director, "the machine represents great value."

Being able to fully machine components on a single machine also eliminates



GF Machining Solutions has introduced the Mikron MILL P 800 U ST machining centre, which integrates milling and turning in a single machine

transfer-related part run out and accuracy errors and helps eliminate production bottlenecks.

The 5-axis simultaneous MILL P 800 U ST is also capable of 4-axis simultaneous turning, a capability often required by customers that need to have the cutting tool positioned at a 90-degree angle to the workpiece surface to avoid tool shape errors. The machine incorporates a

20,000 rpm HSK A63 spindle that is the industry's fastest for a milling and turning machine of this size.

Additionally, water-cooled torque motors on the A-axes and C-axes ensure accuracy and stability, while speed is enhanced through the axes' 0.3-second clamp time in any position.

With the new machine's gantry concept, the workpiece on the 500 mm x 730 mm table is fully accessible without rotating the table. This eliminates errors related to table rotation and avoids the need for hand polishing. The tool changer for the machine is also located so as to avoid moving the table during tool changes.

GF Machining Solutions' Machine and Spindle Protection (MSP) facility adds security to the machining process by protecting the machine and spindle against crashing during setup and machining. As the only system on the market to offer protection in all directions, MSP eliminates spindle damage, misaligned machine geometry, downtime and costs related to unexpected spindle crashes.

The MILL P 800 U ST is automation ready and equipped with pallet changers for two, seven, nine or 12 pallets. It can also be easily integrated into existing automation systems, including System 3R automation solutions.

It can be supplied with either a Heidenhain or Siemens control and up to a 215 position ATC.

GF Machining Solutions is the partner of choice to successful tool, mould and die makers, and to producers of high-value parts in fast-growing market segments. It offers innovative milling, EDM, laser texturing, automation and customer service solutions.

Founded in 1861, GF Machining Solutions is headquartered in Geneva, Switzerland, and currently has 3,255 employees at over 50 sites worldwide. It belongs to the Georg Fischer Group, Switzerland.



The combination of milling and turning technology in a single machine helps manufacturers improve productivity, accuracy and cost-effectiveness

GF Machining Solutions Ltd

Tel: 02476 538666

Email: info.gfms.uk@georgfischer.com

www.gfms.com/uk

Larger capacity 5-axis mill-turn centre from Brother

Manufacturers wishing to carry out prismatic and rotational metal cutting in one hit within a 300 mm by 440 mm by 305 mm working volume can now take advantage of the very high productivity of a Brother 30-taper, 5-axis mill-turn centre. It follows the Japanese machine tool builder's introduction of the Speedio M300X3, which joins the smaller M200X3 that offers 200 mm of X-axis travel. Sole agent for sales and service in the UK and Ireland is Whitehouse Machine Tools, Kenilworth.

Both multi-tasking machines are characterised by an 18.9 kW / 40 Nm tool carousel deploying 22 cutters at up to 10,000 rpm, or 16,000 rpm with the BIG Plus dual-contact spindle option. Below it is an A-axis trunnion carrying a high output, direct-drive, C-axis turning table. Rated at 4.6 kW / 1,500 rpm in the new machine, it is over one-quarter more powerful than the table in the smaller model and generates up to 102 Nm of turning torque. When milling, 30 m/min cutting feed rate maintains a high level of productivity and 400 Nm of C-axis clamping force ensures accuracy is

maintained. A generous A-axis rotation range from +120 to -30 degrees allows machining of features at the rear of components and facilitates loading and unloading of parts at the front of the machine. The axis is tilted by a backlash-free roller drive to promote accurate metalcutting. A holding force of 500 Nm, without the need for mechanical clamping, delivers high speed indexing combined with rigidity when milling parts at an angle or turning them in the horizontal plane.

Non-productive time is minimised by repositioning the X, Y, Z, A and C axes simultaneously during tool change, which takes place in 1.5 seconds chip-to-chip. Linear rapids are 50 m/min and the A and C axes move at up to 50 and 200 rpm respectively. The spindle motor's fast acc/dec and a highly responsive servo control enable a start-up and stop time of 0.2 second. The turning table reaches 1,500 rpm from zero is less than 0.3 second.

Accessibility for workpiece transfer is ergonomic and the wide door opening can be automated to allow robotic component



load / unload from the front, enabling extended periods of unattended and overnight running in high production environments.

Whitehouse Machine Tools Ltd
Tel: 01926 852725
Email: timw@wmtcnc.com
www.wmtcnc.com

Australia's largest machine tool

Starrag is supplying a Droop+Rein 5-axis gantry machine with an 11 m rotary table to the other side of the world.

The Australian Government, Commonwealth of Australia, selected French company Naval Group to deliver a fleet of 12 regionally superior submarines, to be known as the Attack Class, for the Royal Australian Navy. The Attack class fleet will be built in a modern submarine construction yard in Osborne, South Australia.

The Future Submarine Program will deliver Australia a capability that can be built, operated and maintained with sovereignty, which maximises opportunities for Australian industry throughout all phases of the program.

As the design of the Attack class progresses, Naval Group continues to deliver on its commitment to achieve this through its suppliers, a pool that now includes the Starrag Group.

Starrag has been selected to supply a Droop+Rein G 110TT HR100 C vertical

gantry machine, capable of handling both large hull elements and high-precision components for submarine construction. With traversing paths of 14,000 x 13,000 x 3,500 mm in the X/Y/Z axes and an 11 m turntable, the gantry will be the largest machine tool ever put into service in Australia.

Starrag is collaborating with the Australian machine tool manufacturer H&H Machine Tools Australia to deliver this important equipment. The company will manufacture key components, supply qualified personnel to help install the gantry and provide technical support for the entire life cycle of the machine, securing an enduring role in servicing and maintenance in the future. Starrag will provide H&H with the necessary expertise through on-site training and quality control, transferring critical skills and ability to Australian industry.

The contract was awarded following a complex selection process. Noting its many years of experience and its extensive, not



merely technical, expertise in handling large, complicated projects, the Starrag Group was an obvious selection for this contract. Not every machine supplier can manage an order of this magnitude from over 15,000 km away, but this is no problem for the Starrag Group, as Australian sales partner H&H Machine Tool Solutions will facilitate local work, ensuring that everything runs smoothly on-site. A previous project carried out in South Australia, for which Starrag supplied four machines for aircraft construction, shows a proven track record in this regard.

Starrag UK Ltd
Tel: 0121 359 3637
Email: lee.scott@starrag.com
www.starrag.com

XYZ supplies special VMC for deep hole drilling application

For over 30 years, Taunton-based, Pattern Forme Ltd has been at the forefront in design and manufacture of thermoforming mould tools. The company specialises in producing tools for thin gauge work, mainly in the food industry and thick gauge work for applications, such as, signage. However, the key focus of the business is the food sector where its success has stemmed from a willingness to partner with customers. By offering its experience and being pro-active it can take projects from initial concept to finished mould tool, often with lead times as short as two to three weeks.

The food industry is fast-paced and constantly changing, therefore Pattern Forme has continually invested in machining technology allowing it to keep pace. More recently, the trend has been for larger mould tools to increase productivity, this led to a need to drill deeper holes. Typically, these holes would range in size between 6- and 10 mm diameter, with depths up to 1,000 mm. The traditional solution would be to purchase a dedicated deep hole drilling machine or subcontract the work. The former would require a significant investment, whereas, the latter brings logistical problems and lack of control over production. XYZ Machine Tools was able to propose and deliver a quicker and more cost-effective solution.

"It was a chance conversation with XYZ Machine Tools, who have supplied us with several machines, where I mentioned that we needed this extra capacity. They immediately suggested modifying one of its XYZ 1000 LR vertical machining centres to give the extra z-axis capability we required. The simple and cost-effective solution was to add a 1,050 mm riser block to the



machine, which would allow us to drill these holes from either end using the 500 mm z-axis of the machine," says Paul Wilkins, managing director of Pattern Forme.

By reconfiguring the machine, XYZ Machine Tools was able to increase the minimum distance from spindle nose to table to 1,050 mm with the standard Z-axis stroke making the maximum distance 1,550 mm which was more than enough to accommodate Pattern Forme's components. The order for the machine was placed in November 2019 and delivery to Pattern Forme took place in April 2020. Upon arrival, drill testing took place and the standard through spindle coolant delivery of the machine at 20 bar proved sufficient and all that was required was the addition of a Filtermist system supplied by LNS. Now, using either gun-type drills or solid carbide twist drills, Pattern Forme can further develop its deep hole drilling capability.

"This machine has been purchased purely for deep hole drilling and, considering the modifications, it is proving to be of excellent value with the capital cost alone around 80 percent less than a dedicated deep hole drilling machine. Efficiency will also improve as we can transfer work from what previously had been done on manual machines to a fully CNC controlled operation. A further advantage of this capability from the XYZ 1000 LR is the reduction in lead times, which is crucial if we

are to maintain existing and win new business," states Paul Wilkins.

XYZ Machine Tools is renowned for its extensive range of standard machine tools. However, this collaboration with Pattern Forme is a perfect example of how it listens to its customers and responds in a very timely manner to their specific requirements. The solution presented by XYZ Machine Tools from a standard vertical machining centre is one that would have been difficult to find anywhere else and/or have been prohibitively expensive.

XYZ has been developing, testing and refining its range of machine tools for over 35 years. Winning principles of combining outstanding build quality with some of the



world's best control systems, namely ProtoTRAK® and Siemens, has seen the product range become a popular choice for prototype and low volume production.

XYZ Machine Tools
Tel: 01823 674200
Email: sales@xyzmachinetools.com
www.xyzmachinetools.com



New machining centres arrive at GM CNC

Exclusive UK & Ireland agent for Victor Taichung machine tools, GM CNC has announced the arrival of two new machining centres, the compact F76 and the Vcenter-G135. Available to order from the Oldham based machine tool company, whose brand-new warehouse and showroom facility is due to be completed in early 2021, the new Vcenter-G135 vertical machining centre supersedes previous models with several new innovations.

Replacing the Vcenter-145, the new G135 incorporates a BT50 6,000 rpm belt driven spindle. The new spindle motor delivers 15/18 kW power through a two-stage gearbox which provides an extremely high level of torque throughout the speed range. This improves material removal rates significantly. Complementing this, the new G135 has a multitude of new enhancements added to the machine structure to deliver stability and rigidity to match the increased power while retaining Victor's reputation as one of the most robust machine platforms in the industry.



Some of these new innovations include a new angular encoder design, a powerful new FANUC 0i-MF plus CNC control, an X/Y structure that incorporates four box slideways in the Y-axis to avoid table bending at the end of X-axis travel and the chip and coolant collection being redesigned to be housed within the base to reduce machine footprint.

The Z-axis is built upon a wide-span A-form column that, when combined with the new X/Y structure and increased ball screw diameter of 50 mm, provides a platform equally rigid to the much larger Vcenter-165 model. With an X, Y and Z-axis travel of 1,350 by 700 by 700 mm, the Vcenter-G135 offers a powerful, robust platform for heavy-duty cutting that is beyond the capabilities of most machining centres in its class.

GM CNC supplies a wide range of machine tools to the home and overseas markets. The company operates from its own two-acre site having combined lifting facilities of 60 Tons with over 24,000 sq ft of warehouse space. Its commitment to the business is unquestionable which is indicated by its growth over the past 24 years.

GM CNC Ltd
Tel: 0161 401 8880
Email: info@gm-cnc.com
www.gm-cnc.com



THE AJAX SUPER MINI LATHE



Ajax AJAT210

SUPER MINI/CNC LATHE SIEMENS CNC Control

210 mm Swing x 400 mm

100 mm 3 jaw chuck, 240V 1ph

(Fits in a 13 amp plug socket)

4 Station Automatic Toolpost, Coolant,

On wheels, will go through a normal door

(Larger model also available/Super Mini Mills also available)

£10,950.00
+ VAT

See it cutting on our website

Ajax Machine Tools International

Tel: +44 (0)1590 676000

sales@ajax-mach.co.uk

www.ajax-mach.co.uk

Next generation sliding head technology

Derbyshire-based sliding head lathe supplier, Star Micronics GB Ltd has witnessed a high level of demand for its eagerly anticipated SX-38 Type A model with the first UK machine already pre-ordered ahead of its arrival from the factory.

The latest offering from Star, the "SX Series", represents years of machine tool research and development to produce the next generation of sliding head lathe technology. Delivering unrivalled metal cutting performance within a modest footprint, the ergonomic SX-38 Type A is a breakthrough model ideal for complex mill-turn parts.

For machining on the main spindle, the SX-38 features a 10-station turret and an opposing 4-station gang-type tool platen. In addition, the fully programmable swivelling B-axis offers 4 driven tools for machining on the main and 4 counter spindles for the sub. Mounted on an independent Z3-axis, the turret utilises Star's unique quick-mount tool units which maintains compatibility with existing models.

Packed with a range of innovative features, the 12-axis SX model also includes Star's "super-position mode" for simultaneous machining of two different features, "Star Motion Control" to minimise idle times, hydraulic clamping for the B-axis tool post that provides full 5-axis machining capability, built-in 11kW main and sub spindles for improved metal removal rates. 8-station back working tool post with Y-axis for increased machining overlap and switchable guide bush and non-guide bush modes for increased versatility are also featured.



Weighing in at nearly 6-tonnes, the SX-38 incorporates a rigid 60° slanting bed for greater accessibility and improved chip disposal. In addition, dovetail guideways have been adopted for the X3, Y3 and Y2 axes for increased stability during heavy-duty cutting. Coolant volume has also been optimised without compromising ergonomics with the inclusion of a removable 375 litre wraparound tank.

The very first of the new SX machines has been pre-ordered by Vixen CNC Limited, a specialist supplier of mill-turn components located in Gwynedd, Wales. With 20 existing Star models on-site offering up to 42 mm diameter capacity, the acquisition of a new SX-38 further enhances its machine tool portfolio and marks another significant milestone in the growth of the business.

Vixen CNC's managing director, Jake Wood says: "Remaining at the forefront of the turned parts industry is of great importance to us and our continued investment in the latest Star technology allows us to offer customers unparalleled response times, superior quality and full manufacturing flexibility.

"The SX-38 offers significant benefits and further increases our sliding head capabilities. We work with a vast range of materials and supply finished parts to a wide array of sectors including automotive, medical, marine and fasteners. Our new SX

machine will give us the ability to explore additional business opportunities and reinforce our position as a leading global supplier."

Star GB's operations manager, Alec Warner, adds: "The SX-38 offers mill-turn component manufacturers unrivalled metal cutting performance, accuracy and versatility within a compact footprint. We're delighted with the level of interest the SX has already generated from sliding head users eager to expand their capabilities. Given their recent investment record in high technology machinery, it's no surprise that Vixen CNC ordered at the earliest opportunity and I'm confident the SX will surpass their expectations."

Following strong enquiry levels, Star GB predicts that the new SX model will be a popular addition to its comprehensive range of 38 mm machines.

Star Micronics GB Ltd is the wholly owned UK and Eire subsidiary of Star Micronics Co Ltd, which produces sliding-headstock lathes at its plants in Japan, China and Thailand. The GB subsidiary, in addition to supplying its parent company's multi-axis, sliding-headstock mill-turn centres, is also the sole UK agent for the entire range of FMB automatic bar feeders and JBS compensating guide bush systems from Germany.

Star Micronics GB Ltd
Tel: 01332 864455
Email: sales@stargb.com
www.stargb.com



Decade-long association with machine tool supplier pays dividends

Established in 1982, Hi-Force is a leading UK designer, manufacturer and global supplier of hydraulic tools such as torque wrenches, bolt tensioners, jacks, crimpers and cutters, nut splitters and flange spreaders. In addition to offering 2,000 standard products for sale and rental, the Daventry company's engineering team develops custom hydraulic tools to meet the needs of a multiplicity of end users.

Having previously subcontracted its component production, the company decided in 2008 to open its own machine shop and bring a majority of metalcutting in-house. A couple of years later it relocated to new, purpose-built premises.

The first machine tool purchases were a 5-axis machining centre and NL3000 lathes from DMG MORI, closely followed in 2010 by an NT 4250 turn-mill centre. Earlier this year the latter machine was replaced by a more modern NTX 3000 7-axis multi-tasking version. More than 80 percent of the 20 CNC machine tools on-site are from this supplier.

Chris Dickinson, a time-served engineer,

has been with the company since 2003 and is currently group operations director responsible for all aspects of manufacturing including material sourcing, machining, assembly, testing and distribution.

He says: "The previous NT 4250 gave us remarkable service, but we thought it prudent to upgrade to the latest model from DMG MORI, which incorporates newer technology, provides greater flexibility and is more economical to run.

"If the machine did not have seven CNC axes, it would have increased the number of operations needed to produce our components and so lead-times would have been longer.

"We could have managed to manufacture our standard ranges with suitable production planning, but it would have been less economical and would have unacceptably lengthened delivery times of our specials."

The primary reason for buying the former turn-mill centre was to produce aluminium housings for higher-torque tools in the Hi-Force product programme. However, the



replacement machine is cutting a variety of materials, mainly aluminium but also alloy steels including EN24T and EN30B in an annealed condition. 100 tools in the magazine provide flexibility when setting up a new job, as the required cutters are normally already present.

DMG MORI UK Ltd
Tel: 0247 651 6120
Email: steve.finn@dmgmori.com
www.dmgmori.com

Used sliding-head lathe receives full support from the manufacturer

Despite starting out more than 25 years ago, Dudley-based TWP Manufacturing opened its CNC machine shop as recently as the beginning of 2019 to produce in-house most of the components needed for its proprietary products. They include photographic darkroom and studio equipment, gardening products including wheelbarrows, and security anchors. The firm also provides subcontract pressworking and injection moulding services to a wide range of industries, particularly the automotive sector.

Vertical machining centres and a single-spindle, fixed-head bar auto are to be found on the shop floor, but in May 2020 the company bought its first sliding-head twin-spindle lathe, a 20-year-old Citizen Cincom M32 equipped with an Iemca Boss 432r barfeed. It was originally sold in 2000 by the Japanese manufacturer's agent for the British and Irish markets, NC Engineering, which in 2008 became a wholly-owned subsidiary, Citizen Machinery UK.

Phil Stanley, a director of TWP Manufacturing says: "We were previously

outsourcing the production of a lot of our turned parts, including to subcontractors in the Far East.

"However it became apparent that, the way we were expanding, it would be necessary to bring component manufacturing in-house to cope with the higher volumes as well as to have more control over production."

To fulfil the predicted quantities, the company recognised that it needed a turning centre with more speed and capability than its fixed-head lathe without driven tools, as when using this machine there was frequently a requirement for additional operations.

Sometimes a component needed to be parted off and inverted in the chuck if it required machining on the reverse end. If milling and drilling were involved, they had to be accomplished by setting up the job on a machining centre. Furthermore, many components formerly required manual depipping, adding a lot of labour cost content to their production.

None of this is necessary on the Cincom. It is able to synchronously and automatically



transfer a component from the main spindle to the counter spindle for back-end machining while front-end operations are carried out simultaneously on a new length of bar. Prismatic features are added in the same cycle using live cutters and the tool carrier's Y-axis. Components come off the lathe pip-free after parting off due to close control over the machine's spindle speeds and feed rates while production times have drastically reduced.

Citizen Machinery UK Ltd
Tel: 01923 691500.
Email: sales@citizenmachinery.co.uk
www.citizenmachinery.co.uk

Manufacturing aircraft components more efficiently

Coolant rhenus TU 43 P performs optimally with materials that are difficult to machine and has numerous aviation approvals

Aircraft manufacturers and suppliers of aircraft components are well aware that the high strength materials used in aircraft construction are particularly challenging to machine. Approved for aviation by renowned manufacturers including Airbus, Safran and Bombardier, rhenus TU 43 P ensures excellent component quality.

Using the correct machining fluid plays a decisive role. Lubricant expert Rhenus Lub has the perfect solution; its special coolant rhenus TU 43 P. The special coolant impresses with long tool life and facilitates a smooth, more cost-effective machining process. It not only plays a leading role in the aircraft sector but has also proven itself as a real all-rounder in many other industries with a similar range of materials.

Staying cool at maximum performance

Aircraft elements push machine tools to their limits. Coolant rhenus TU 43 P, developed for a broad range of materials, rises to this challenge. As a true all-rounder, it helps users to find the optimal balance between service life, process safety and machining time, specially tailored to highly challenging machining in the aviation industry. In concrete terms, it enables high cutting and feed rates with optimal cooling and improved tool quality.

A practical example also demonstrates the process-optimising performance of the special coolant: "When Inconel is turned, the service life of the carbide inserts used was increased by 50 percent, resulting in a significant reduction in tooling costs," says Daniele Kleinmann, director of product management for coolants at Rhenus Lub. Another property of the special coolant that adds to its cost-effectiveness is its low additive concentration, levels below two percent are quite common. Furthermore, users benefit from its very stable emulsion service life of more than one year. The numerous aviation approvals for rhenus TU



43 P act as an important assurance for suppliers to the aviation industry.

The all-rounder coolant for cross-sectoral applications

Besides being used in aviation, rhenus TU 43 P also impresses in other sectors when it comes to process optimisation, wherever grinding, turning, drilling, milling or thread machining of steel, stainless steel, aluminium or titan is the task at hand. For example, rhenus TU 43 P optimises machining operations in the automotive, mechanical engineering and steel machining industries.

The lubricant specialists at Rhenus Lub deliberately took environmental protection and occupational safety into account when formulating the product. "rhenus TU 43 P does not contain any components from the SVHC list, has good skin compatibility and is easy to handle thanks to its water hazard class 1," says Jörg Kummerow, head of global customer development at Rhenus Lub. With its outstanding rinsing properties, rhenus TU 43 P guarantees clean machines, tools and workpieces, reducing the amount of cleaning required.

Rhenus Lub is an international system provider of special lubricants, application consulting services and process solutions for metalworking and metal processing. The company, which was founded in Mönchengladbach, Germany, in 1882,

develops and manufactures watermiscible coolants and neat oils for demanding machining applications, special products for metal working and special greases and special oils for lubricating roller bearings and other industrial components. Its customers include leading companies in the mechanical engineering industry, the automotive and automotive supply industries, as well as in the roller bearing, food and aerospace industries.

As an innovation leader, Rhenus Lub invests an above-average amount in research and development, with over 20 percent of all employees working in this area. Rhenus Lub is represented in over 40 countries around the globe through its subsidiaries and other representative partners abroad.

The brand is one of the world's strongest brands for special lubricants in a variety of applications and branches. As a premium partner to industry, it knows and understands customers' fluid management. They trust in Rhenus Lub as a highly innovative, reliable specialist with detailed know-how in coolants and industrial greases.

Rhenus Lub GmbH
Tel: 0049 216158690
Email: vertrieb@rhenusweb.de
www.rhenuslub.de



Sludge Barrier removes impurities

Retrofittable separation system removes sludge and residual particles from the cooling lubricant, which therefore lasts longer

Mayfran International, the specialist for material handling and coolant treatment in the metalworking industry, has developed a "Sludge Barrier". The magnetic separation system for the cooling lubricant tank, which can also be retrofitted, removes iron particles. It is suitable for all machining processes involving magnetic materials such as steel, cast iron or nodular cast iron. It can also be used in washing systems for parts cleaning.

Light and portable

The Sludge Barrier is available in different sizes and designs. The Manual Sludge Barrier (SB) catches the chips and small iron particles with a built-in magnet. The stainless-steel construction is particularly compact and easy to carry. It works in water and oil-water emulsions with temperatures up to 60 degrees Celsius. The sludge is emptied manually at certain intervals by means of a demagnetising lever. This means that the unit does not need its own power supply.

Retrofitting to practically any existing coolant tank is possible without any problems. Two sizes, which differ in terms of magnetic flux density and their maximum absorption capacity, are initially available. The SB4012 offers a maximum holding capacity of 1.6 kgs of cast iron chips or approximately one kg of short steel chips at a flux density of 970 Gauss, 0.097 Tesla. The SB4024 reaches 1,200 Gauss, 0.12 Tesla, flux density and can hold up to 3.6 kgs of cast iron or 2.7 kgs of steel chips.

Automat also removes tramp oil and floating sludge

The Auto Sludge Barrier (ASB), also made of stainless steel, catches the particles on a circulating magnetic strip. A long drying zone ensures that the sludge is as dry as possible before it is automatically discharged into a collection container. Its compact design combines high performance with a small footprint. An easily adjustable timer function minimises coolant carry-over. In addition, the ASB also



removes tramp oil and floating sludge from liquids in a machine tool.

The automatic version of the Sludge Barrier can also be retrofitted to practically all existing coolant tanks.

Mayfran GmbH
Tel: 0049 241 938720
Email: info@mayfran.de
www.mayfran.com

Environmental and productivity benefits

Rimann AG is a leading supplier in filtration, separation and chip separation devices with a focus on environmental recycling and reusing in the metalworking industry. Its latest project involved supplying the Wogaard Oil saver and new chip bins to Neida Bartschi AG in Switzerland.

Rimann AG has worked for many years for the company Neida Bartschi AG, supplying them with ARYMA 51-2 chip spinners to separate the neat oil from the chips. This ensured the swarf was less than three percent moisture dry along with re-using the oil.

Neida Bartschi AG had recently upgraded all the sliding head machines to increase productivity, however were using old chip bins/trolleys from the older machines. The conveyor also dragged a lot of oil in the chip trolleys so the machines would stop at night because there was not enough oil in the machine tank causing a number of hours of lost production.

Additional issues were created when tilting and emptying the swarf from the full chip trolleys in the ARYMA Chip spinner.



The high amount of oil flushing in and out of the centrifuge was counter productive.

Much of the work Neida Bartschi AG manufactures is for the medical industry, so no oil mixing is allowed between machines. Even after spinning the swarf and chips, the drained oil could not be re-used on these machines resulting in higher oil costs and usage.

The old chip trolleys were not long enough for the conveyor, so oil and chips dropped on the floor causing health and safety issues.

Rimann AG's solution was to introduce the Wogaard Oil Saver and ARYMA chip trolleys. The Wogaard oil saver unit is connected to the machine's pump and



reclaims the fresh oil as soon as it drops into the chip bin and takes it back to the machine tank. As it is connected to the machine pump, it works automatically when the machine is in operation so no additional manpower is required. Wogaard also does a similar device for soluble coolant.

As a result of the project, the oil is now going back into the same machine, a much cleaner environment has been created and the customer is pleased with the solution.

Wogaard Ltd
Tel: 0208 935 5182
Email: Jh@wogaard.com
www.wogaard.com

ROCOL introduces multipurpose fluid for machine shops

Industrial lubrication expert ROCOL is once again answering the ever-evolving needs of industry with the launch of its new ULTRACUT 370EP cutting fluid. Providing 'performance you can trust', the new ULTRACUT 370EP cutting fluid is a semi-synthetic fluid that can be utilised as both a cutting fluid and grinding fluid, exceeding existing coolant performance while improving environmental credentials and inventory management.

The new addition to the ROCOL stable of industry-leading fluid solutions has been developed in the UK to exceed performance expectations as well as environmental and industry-standard conformance for end users. Containing ROCOL's unique Extreme Pressure (EP) additive package, the new ULTRACUT 370EP can be applied to enhance medium to heavy-duty machining performance, generate surface finish and component quality enhancements as well as tool life longevity that will be visibly noticeable by both your customers and your bottom-line profitability.

Furthermore, the new high performance, semi-synthetic, water-miscible metalworking fluid has been formulated for application on ferrous and non-ferrous materials, meeting stringent industry requirements and minimising the corrosion and staining of components with its exceptional residual corrosion protection. With an expert blend of additives, the new ULTRACUT 370EP is tolerant to tramp oil, it retains a low level of foaming and is durable for use in both hard and soft water environments.

When mixed with water, ULTRACUT 370EP forms a translucent blue micro-emulsion that provides a clear view of both the workpiece and the work envelope during machining and grinding applications. The fluid can be applied in dilution ratios from 30:1 to 75:1 and dilution ratios should be adjusted depending on the machine tool, workpiece material, water hardness, application and severity of operation.

With high dilution ratios possible, ULTRACUT 370EP will provide significant cost savings with a single barrel capable of providing up to 15,200 litres of fluid. For cutting processes, dilution ratios of between



40:1 and 60:1 are recommended and for grinding processes, the advised dilution with water should be 50:1 to 75:1, depending on the severity of the operations. To ensure dilution accuracy, it is preferable to use a ROCOL automatic fluid mixer. For manual mixing, manufacturers should always add the ULTRACUT 370 EP concentrate to water at the recommended dilution ratio, stirring continuously.

Of course, running a business is enough of a challenge and that is why the experts at ROCOL formulated the ULTRACUT 370EP to be used for both cutting and grinding operations.

This enables the end-user to rationalise the fluid across the shop floor, covering machining and grinding to provide absolute simplicity whilst taking away the added complications of having two different fluids on site. Being a leader in fluid solutions and management, ROCOL has taken user-friendliness to another level with a fluid that when diluted is safe, clean, operator-friendly and has been designed for minimal hazard labelling according to CLP. The new ULTRACUT 370EP is free from components such as bactericides, chlorine, formaldehyde, nitrites, silicone and any animal-derived materials.

So, if you want to reduce your fluid inventory and costs as well as your operational costs while improving the

performance of your machine tools, cutting tools and the quality of your components, give an expert at ROCOL a call to find out more.

ROCOL is part of ITW, a multi-national US owned, Fortune 150 company. It develops, manufactures and markets technically advanced industrial lubricants and line marking systems to industries worldwide.

The company was founded upon the work of Victor Ivanovitch Ragsine, born in Russia, who took a degree in chemistry at the University of Moscow in 1854.

Based in Leeds, UK, the origins of the company date back to 1878 when Victor Ragsine developed a yellow lubricating oil which he subsequently sold throughout Europe. Unlike other lubricating methods, the yellow oil was virtually non-corrosive making it technically superior to other products available.

In 1882, the UK agency manager Ernest Glehn bought out Victor and the Russian parent company and established Ragsine and Company, later to be developed into ROCOL.

ROCOL
Tel: 0113 232 2600
Email: enquiries@rocol.com
www.rocol.com

Maintain coolants using specialist additives

While we all navigate the current uncertainties, the one common factor and important thing to remember is that we are all in this together. Some production facilities have restrictions in place and are not in a position to allow contractors on site, which can raise some unforeseen issues, especially when it comes to water-miscible cutting fluids. To minimise the impact this restriction has on production, Oemeta UK has developed a comprehensive package for businesses looking for guidance.

Oemeta UK is highlighting the benefits of using additives in coolants, to maintain or prolong a fluid's qualities. Whatever situation you find your production in, preservation is highly important during this time.



On the one hand, you may find that your production is not reaching its full potential and you are in a position where you need to reduce the number of your working machines, or unfortunately, even consider shutting-down operations for a period. There are a number of additive options which can prolong the life of coolant for when work picks up again, these include: pH buffers, bactericides, fungicides and biocides. System cleaners are also an option for periods of shutdown and prepare machines for a problem-free refill.

pH buffers are used to increase coolants pH that may have been degraded due to a reduced workload and the ingress of microbiology. Bactericides are used to treat machine tanks that are infected with bacteria and may be producing bad smells or as a pre-treatment, where the machine is anticipated to be shut down for a prolonged period. Fungicides are used to treat machine tanks where fungal solids have been visibly detected, either on coolant tank walls or partially blocking coolant nozzles.

Biocides will treat tanks infected with both bacteria and fungus. They are very effective, but care must be taken and all safety advice followed when treating products. System Cleaners are added before a machine is shut down to kill microbiology, wash down machine tools, internal pipes, coolant tanks and cabinet walls. The use of System Cleaner ensures machine will have no start up issues when refilled with coolant.

On the other hand, your production may be in huge demand and you need to ensure that your cutting fluids are always in tip-top

condition to meet such pressures. If this sounds familiar, then all of the pre-mentioned additives can be considered.

Not only does Oemeta UK provide additives, also included is everything required to use these specialist fluids. Firstly, "how to" documents will be supplied explaining exactly how to handle, dose and the PPE requirements for additives. Secondly, all health and safety documentation will be supplied. Thirdly, Oemeta UK will provide remote training to the individuals tasked with using the additives to ensure they are comfortable with all stages of the process. Additionally, a dosing calculator form to make sure the right quantities are being used is also provided and finally, an easy-to-read measuring container will be sent to use with the additives.

Whatever position your business is in at the moment and if you are a user of coolant, do consider additives. The reduction in microbiology and improved cleanliness offers further benefits, including keeping machine operators safe, preventing damage to machine tools, maintaining good machine condition, reducing waste and keeping costs down.

Oemeta UK Ltd
Tel: 01295 713280
Email: sales@oemetauk.com
<https://uk.oemeta.com/>

WOGAARD

COOLANT OIL SAVING SOLUTIONS

- Up to 50% Coolant Saving
- Up to 90% Saving in Disposal
- Environmental Benefits

www.wogaard.com
 sales@wogaard.com
 +44 (0) 20 8935 5182

Protect your machines with Kraft & Bauer

New automatic bottle weighing systems

Kraft & Bauer, whose automatic fire extinguishing systems are fitted to all kinds of machine tools, offers a complete range of systems from small 5 kg CO₂ based models to protect the smallest of machines up to huge multi cylinder variants having multiple 50 kg bottles.

One popular option is to have the CO₂ or argon gas cylinders contained within its own stand-alone cabinet that can be bolted to the factory floor and/or placed directly against a machine. These may be optionally equipped in the case of using CO₂, as the fire extinguishing media, with automatic weighing systems. These monitor the weight of the CO₂ cylinder and, in case it is empty, will not allow the machine to be run, thus providing added protection.

From its base in Coventry, Kraft & Bauer UK offers a full installation, retrofit and service facility for all Kraft & Bauer fire extinguishing systems. These must be checked at least annually by a qualified technician and signed off for companies insurance purposes. In the event of an incident, if there is not an annual service certificate in place then it is likely that any insurance claim will be declined.

It is mandatory to have fire extinguishing systems fitted to machine tools that provide some form of a fire risk. These are generally acknowledged as any machine that works with an oil-based coolant, ie. most grinding machines and turning machines and any



machine that causes a spark such as an EDM machine or laser machine. Engineering manufacturing companies must have documents for risk assessments in place and these need to highlight risks such as fires on machine tools. Companies must act using mitigating measures to overcome those risks. In the case where machines are run automatically, fully automatic fire systems need to be used that can react in seconds to put fires out.

Kraft & Bauer UK, whose fire extinguishing systems protect many hundreds of machines here in the UK, has expanded further with the addition to its fleet of a larger long bed van that doubles as a mobile workshop. A further service engineer has also been employed and



additional stock has been added to both of its storage facilities in Coventry and in Cork.

As more and more new machines are fitted with Kraft & Bauer's systems, naturally the global annual servicing of those systems increases. Kraft & Bauer notes that partly due to insurance companies being ever more vigilant and refusing insurance for machinery that's not adequately protected against fire risks, the retrofit market is driving many sales here in the UK and in Eire.

Louise Boraston, MD at Kraft & Bauer, who has been championing fire protection on machine tools for a number of years now, is naturally pleased to see the increases in sales but stresses that its far more satisfying to see sales due to companies understanding the importance of fire protection and acting responsibly rather than only reacting to fire incidents that have sadly resulted in the loss of machines and therefore production.

Kraft & Bauer urges those using all kinds of machine tools to understand the need to protect their workers and machines from the risks of fire. It points out that in the event of a machine being damaged and put out of action the replacement costs will almost certainly not be covered by any insurance policy unless a fire system has been fitted to it. Also, it should be understood, that even if end users are eventually successful in making a claim, it can take many months and then several more months to take delivery of replacement machines and very few end-customers will wait for production to recommence. Most will likely simply go elsewhere and therefore important contracts can be lost, in some cases, forever.



Kraft & Bauer UK Ltd
Tel: 02476 229477
Email: sales@kraftandbauer.co.uk
www.kraftandbauer.co.uk

DON'T LET YOUR INVESTMENT GO UP IN FLAMES!



 **kraft & bauer uk**

AUTOMATIC FIRE SUPPRESSANT SYSTEMS
(WILL FIT TO ANY MACHINE)

Kraft & Bauer UK Ltd

Unit 80 Hotchkiss Way, Binley Industrial Estate, Coventry. CV3 2RL
(t) 02476 22 94 77

www.kraftandbauer.co.uk

(e) sales@kraftandbauer.co.uk

BIG KAISER optimises automotive machining

Available in the UK from Industrial Tooling Corporation (ITC), BIG KAISER fine boring technology has been delivering impressive results for automotive manufacturers on the continent. Applying expert knowledge and combining this with digital technology and optimised indexable inserts, Schmauser Müller Metalltechnik has substantially increased process reliability and efficiency with its new fine boring processes. In the process, the company has increased tool life by a factor of three.

Schmauser Müller Metalltechnik is a Bavarian-based CNC manufacturing company that produces precision one-off and small series runs with its service portfolio rounded off by fixture construction, metal technology and associated CAD design.

"As a Bavarian company, we naturally serve automotive manufacturers, but to limit our industry exposure, we maintain a diverse customer base," says production manager, Rainer Maurer. "Our first encounter with the BIG KAISER project was the digital twin, which is a virtual model of a real-world process, object or system. It ensures that the user can be sure of success even before the actual process begins. Digital twins are particularly useful for one-off parts when



there is no previous data available and the part must be made right the first time."

SM Metalltechnik uses HSM Works CAM software from Autodesk, where a digital twin is created for all relevant components. In this case, the twin simulates the 5-axis C42 Hermle machine with HS-Flex automation and clamping devices from SMW Autoblok.

The tools are also digitally reproduced and with the BIG KAISER fine boring heads available from ITC, this includes the projection of adjustable lengths and diameters.

Once all the components are depicted, it is possible to simulate the best program sequence and a miscalculation in this area could result in a collision.

"A truly professional process must run reliably the first time, every time. We routinely run our parts through the simulation and have full confidence in the final results. This process ideally complements our modern machinery," continues Rainer Maurer. "Luckily, our Hermle machine was 'digital twin ready', although we sometimes failed because we lacked precise complexity parameter data. This led to unpredictable results as each extension combination has a different digital twin. To overcome this, BIG KAISER provided us with the required data for all the relevant lengths and diameter combinations."

Digitisation was not the only factor that contributed to SM Metalltechnik's growing

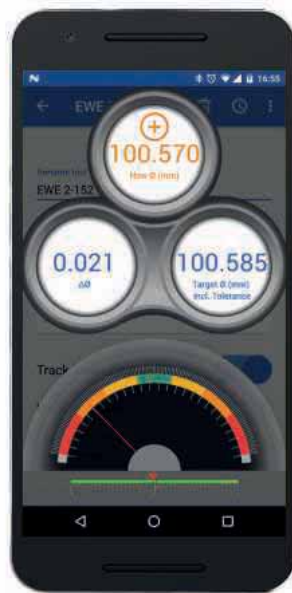

success in the fine boring process. "Having used many different cutting materials in the past, we were not sure which inserts were best suited to a particular project," recalls Rainer Maurer. "Our guesswork often resulted in inserts breaking and unsatisfactory results. Not surprisingly, employees became reluctant to take on fine boring work. This has all changed and today, we have a total of just 11 inserts at our facility, each for a clearly defined task and purpose."

BIG KAISER has painstakingly optimised the cutting values for every diameter, every material and every projection length. The same applies to different spindle types. The BIG KAISER App makes the test results available to ITC customers, enabling them to fully concentrate on their core business.

Rainer Maurer concludes: "With our fine boring process, we enter the desired parameters in the app, such as bore



diameter, material and projection length. The App then tells us which of our BIG KAISER tools is to be fitted with which insert, which extensions may be required and what cutting data is to be set. Then, we select the corresponding digital tool twin on the CAM workstation and program in the cutting values, that's it. The operator no longer has to experiment with different values but can rely on the results generated by the App, which simplifies the process enormously. The lifetime of our tools is now three times longer than before. More importantly, we replace inserts after a pre-defined period of use instead of waiting until something goes wrong."

Industrial Tooling Corporation Ltd
Tel: 01827 304500
Email: sales@itc-ltd.co.uk
www.itc-ltd.co.uk

When something exceptional develops between us:
That's the MAPAL effect.



You

are looking for the tool to
produce the best surface finish.

Perfect
finish

We

supply the solution for
economical milling processes.



High accuracy round insert cutters

For machining difficult-to-cut materials with a high level of accuracy and efficiency, Mitsubishi Materials has expanded its ARP series of round insert, high runout accuracy milling tools.

ARP is ideal for machining titanium and other heat resistant alloys as well as stainless steels that are commonplace in the aerospace and power generation industries. The ARP series has delivered tool life improvements and significant cutting force reductions when compared to other products.

These significant gains have been achieved by developing an extremely accurate insert seat pocket that improves radial runout accuracy by 25 percent when compared to conventional products. This also realises minimal change of run-out accuracy when indexing the inserts. Furthermore, ARP tool bodies deliver an exceptionally strong seating configuration that has two side location faces to prevent

inserts from moving during cutting. This robust positioning is complemented by an innovative insert geometry design that has a special rake face to generate smooth chip flow and reduce cutting resistance. This development creates an even chip flow and directs the cutting forces towards the centre, the strongest part of the insert pocket.

A new grade and type of insert have been added to the range with eight side seating faces that are ideal for use at lower depths of cut and can effectively double usage of the insert. The range of the traditional four side seating face inserts has also been expanded. These new inserts have an improved structure with a wider core and thickness to help combat sudden fracturing under heavy machining conditions. A new addition added to the range is MP9140, a new PVD coated carbide grade. Combining a smooth top surface of the Al-rich AlTiN coating layer and a special cemented carbide substrate, makes MP9140 ideal for machining titanium and heat resistant alloys. In total, there are four different high-performance grades that can be combined with several different chipbreakers to optimise the choice and cutting performance for a wide range of light, medium and roughing applications.

The ARP series is available with cutter bodies that include shell types in diameters 40 through to 100 mm. These bodies offer course, fine and super fine insert pitches with a choice of four to 11 inserts per tool depending upon the selected diameter. For machining smaller surface areas and intricate forms, Mitsubishi also includes a shank type tool that is available in standard

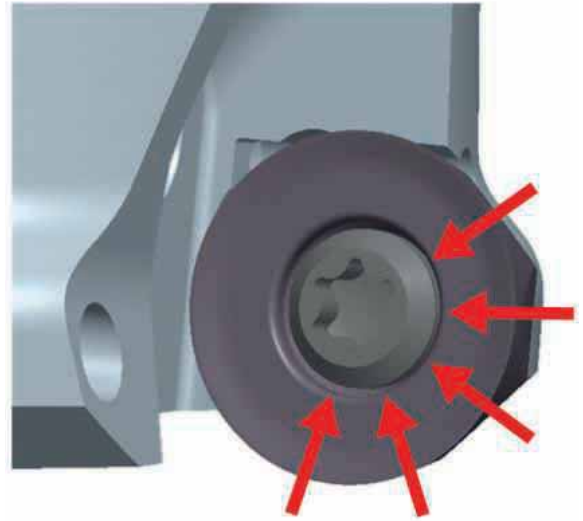

and long lengths for processing difficult to reach cavities and forms. These standard and long reach tool bodies are offered in diameters 25, 32, 40 and 50 mm with two to five inserts to meet a vast range of machining applications. In addition, versatile screw-in type tool bodies in 25, 32 and 40 diameters are also available.

MMC Hartmetall GmbH located in Meerbusch, Düsseldorf is a group company of the Japanese Mitsubishi Materials Corporation and European Headquarters of the cutting tools division. For over the past 30 years, the company has been delivering cutting tools and integrated solutions that meet its customers' needs while keeping up with the latest market trends. The European Headquarters represents Mitsubishi Materials Corporation in Europe. Additionally, there are five sister companies in the UK, Italy, France, Poland and Russia.

MMC Hardmetal UK Ltd
Tel: 01827 312312
Email: sales@mitsubishicarbide.co.uk
www.mmc-hardmetal.com



DRAGONSKIN
The coatings for
the highest performance



For more information:
cutting.tools/en/dragonskin

TEAM CUTTING TOOLS



Tool life improvements with Walter's new AB735 synchronous threading adaptor

Tooling expert Walter GB has announced the new AB735 synchronous threading adaptor that is designed to minimise the axial forces that occur during tapping and threading, caused by the rotation of the machine spindle and its feed travel, to therefore reduce tool wear and, in particular, thread flank wear while reducing the chance of tool breakages.

In addition to extending tool life, the lean, short design of the adaptor, which can be used in all standard ER collet chucks, also makes it ideal for use in tight spaces, for example on turn/mill centres.

More cost-effective than comparable systems, the AB735 features quick-change



exchangeable front pieces to enable different thread sizes and tool diameters, ER16 to ER32, to be used with the same collet and tools with and without internal coolant supply, thus contributing to overall tool cost savings.

Walter stays in the groove

Tooling expert Walter GB has launched the new G3051-P groove turning holder with MX22-2L/R Tiger.tec indexable inserts specifically for grooving along a shoulder. The insert widths of 1.5 mm to 3 mm can produce depths up to 6 mm.

For use on CNC, multi-spindle and auto lathes, the system is suited to a wide range of components, from precision parts for medical devices to automotive camshafts.

The holder is available in shank sizes of 12 to 25 mm and features precision cooling. Inserts are positioned at a 3 deg incline and, because there is a 'level design' on the working face, as left- and right-hand versions, there is no end-face axial contact.

The four-edged inserts are available with

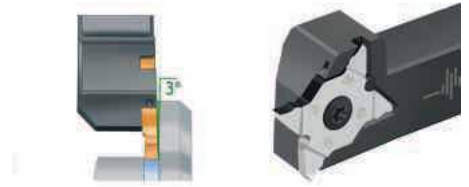

the new GD8 and VG8 geometries, the latter being specifically developed for finishing operations behind a shoulder.

Other important features of the inserts include a large contact surface and patented dowel pin insert location, to provide a high degree of stability, precision and indexing accuracy, plus a tangential positioning arrangement that results in outstanding flatness and surface quality in machining, as well as long tool life and therefore cost efficiencies.

Walter GB Ltd

Tel: 01527 839450

Email: ashley.battison@walter-tools.com

www.walter-tools.com

HELPING YOU
MAKE IT



itc industrialtooling
corporation ltd

CYBER HOUSE, 1 KEPLER, LICHFIELD ROAD INDUSTRIAL ESTATE, TAMWORTH, STAFFORDSHIRE. B79 7XE

T: +44 (0)1827 304500 E: SALES@ITC-LTD.CO.UK W: WWW.ITC-LTD.CO.UK

Follow us on:   

Floyd plunges into productivity gains with new CrazyMill

Mikron Tool has expanded its plunge-mill CrazyMill Cool P&S milling cutter program with the arrival of new dimensions to achieve even deeper machining cycles. Now available in the UK from Floyd Automatic, the new CrazyMill Cool P&S is characterised by the ability to plunge, drill, vertically into the material, mill slots or pockets into solid material in smallest spaces and conclude milling operations with finishing cycles.

While the milling depth in the short version, 2.5XD, was based on the machining of keyways, the extended range aims to be able to mill the deepest possible slots and pockets with a single tool, reaching more distant machining areas of a workpiece with a single tool. The new version of the solid carbide plunge mill is based on the same technology as the short version, transferred directly to the new line. Now, it is possible to plunge perpendicularly into the material and reach the maximum milling depth of 5XD. Despite its length, the milling cutter is extremely stable and at the same time, it impresses with its cutting speeds, chip removal rates as well as long tool life and surface quality, all this from a milling diameter that starts at 1 mm.

The cutting-edge geometry enables process stable and vibration-free 'drilling', vertical plunging, even at a depth of 5XD. This not only prevents the cutting edges from breaking out, which is one of the central difficulties when drilling with a

milling cutter, it also ensures excellent surface quality and extended tool life. Even more, than with the short version, good chip removal plays an important role at this depth. There is a higher risk that chips remain in the milling zone, are broken-up and thus damage both the milling cutter and the milled surface. The special cutting-edge

removal rate. For the user, this means up to five times shorter machining processes and significantly longer tool life compared to other milling cutters on the market."

CrazyMill Cool P&S is now available from Floyd Automatic Tooling in diameters from 1 to 8 mm and for a maximum milling depth of up to 5XD.

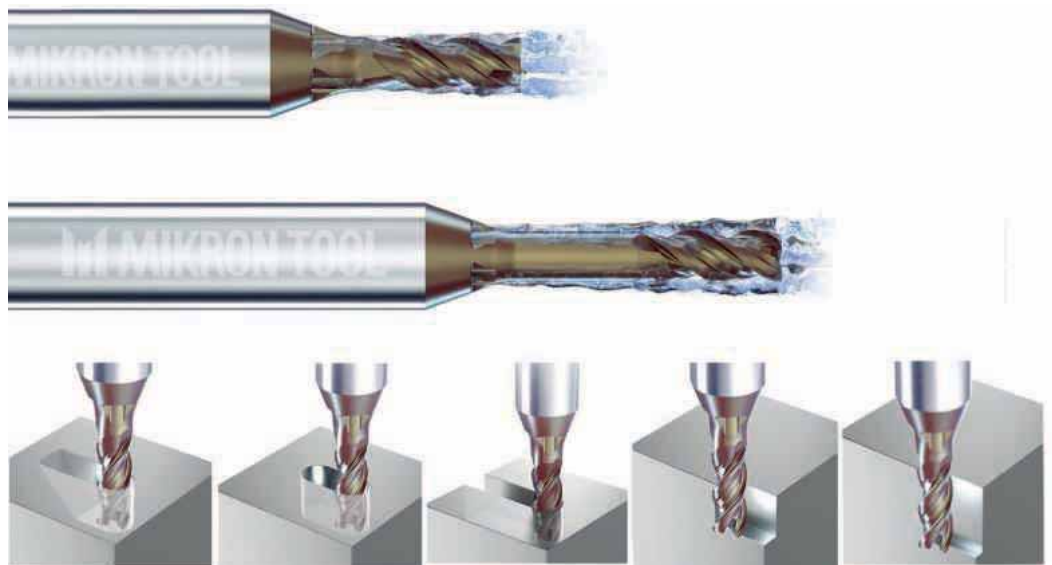

geometry with CrazyMill Cool P&S and its extended chip area provides a remedy. It ensures perfect lateral chip removal during plunging and also tool stability during deep milling. Additionally, the integrated coolant ducts in the shank permit exceptional coolant flow and ensure an efficient chip evacuation, even in the tightest of angled spaces of deep pockets or slots.

Alberto Gotti, head of the Technology & Customer Project Centre at Mikron Tool confirms: "We work with this tool at high speeds and feeds and an axial infeed, ap, of 0.5XD, achieving an extremely high chip

Floyd provides the turned part and precision component machining industry with specialist tooling to a wide variety of subcontract and OEM component manufacturers. The products offered are from some of Europe's top names providing quality at realistic prices.

Floyd Automatic Tooling Ltd

Tel: 01462 491919

Email: info@floydautomatic.co.uk

www.floydautomatic.co.uk

GUHRING
The Tool Company

NEW ISO Insert milling cutters

for the machining of steel, cast iron, aluminium and stainless

T: 0121 749 5544
e: info@guhring.co.uk
www.guhring.co.uk

Milling system for mirror-finish machining

Horn has expanded its DTM face milling system to include inserts for mirror-finish machining of non-ferrous metals and plastics. The DTS inserts, which are tipped with Monocrystalline Diamond (MCD), allow virtually perfect surfaces to be machined and achieve flatness of less than 1 µm. The milling system is used where surface quality has to meet stringent requirements.

DTS inserts are tailored to the DTM face milling system and achieve high levels of efficiency and cost-effectiveness in conjunction with pre-machining inserts. Either Polycrystalline Diamond (PCD) or Chemical Vapour Deposition Diamond (CVD-D) is used for pre-machining, depending on the material being processed.



All tools for mirror-finish machining are generally designed with single cutting edges. The remaining insert seats contain roughing or balancing inserts.

The MCD-tipped cutting edge is set to an axial projection of 0.02 mm. Due to the structural design, the PCD-tipped inserts always pre-cut radially. This means it is virtually impossible for the MCD insert to be overloaded or damaged.

The insert seats of the DTM milling body can be adjusted in the axial direction via an adjusting screw. Every ten-degree rotation moves the insert seat by 0.01 mm. This means that the axial run-out of the individual cutting edges can be adjusted with micrometre precision.

The internal coolant supply ensures targeted cooling of the contact zone and efficient chip removal. The low mass of the aluminium body protects the spindle and reduces energy consumption compared with steel bodies. Horn offers a fine balancing option for the body to achieve high cutting speeds of up to 5,000 m/min and ensure that the tool runs quietly.

The range of applications for mirror-finish



milling is huge. In the tool and mould making industry in particular, the method saves polishing while also increasing the quality of the surface and its flatness. It is therefore used in applications where the surface of the mould has a direct influence on the parts being produced. This includes clear, transparent plastic items or valve plate sealing surfaces, for example. MCD-tipped ball nose end mills are used to produce PET blow moulds and chocolate moulds.

Horn Cutting Tools Ltd
Tel: 01425 481880
Email: info@phorn.co.uk
www.phorn.co.uk

Low cost and high performance

As the engineering manufacturing sector begins its recovery from the downturn attributed to Covid-19, Ceratizit has stepped up to provide a helpful hand in controlling tooling costs. The introduction of its Standard Line range of ISO turning inserts provides customers with significant cost benefits, while retaining the quality and performance expected from the Ceratizit Group.

In order to achieve these cost savings for customers, Ceratizit has streamlined the Standard Line into just three grades, with a reduced number of just seven insert shapes, including the popular CNMG, DNMG, CCMT and DCMT styles, in a range of insert sizes, giving over 100 inserts to select from. As highlighted by the insert designations, both positive and negative inserts are available, with a choice of two chipbreaker styles to suit specific machining applications.

The Standard Line inserts are manufactured to the company's exacting standards at Ceratizit's Reutte, Austria

facility and, by limiting the range to the most popular styles and sizes, volume manufacturing is helping to drive down costs. "The Standard Line of turning inserts will benefit customers, particularly those in the subcontract sector, where batch sizes may be low and frequently changed, and their business is price focused. For example, savings when compared to mainstream competitors can be as high as 75 percent per insert, giving customers the competitive edge that they are looking for in these challenging times," says Tony Pennington, managing director of Ceratizit UK & Ireland.

Special Selections publication

Ceratizit UK & Ireland customers will benefit from some special introductory offers when they receive the latest edition of the machining specialist's Special Selection publication. Included is a range of milling, drilling and turning innovations at introductory discounts of up to 30 percent for orders placed before 30th November 2020.



Among the new products featured is a new standard range of turning inserts targeting the machining of steel components. With standardised geometries and coatings these inserts will provide a first choice for those looking for high performance reliable turning of across a range of standard applications. A wide selection of insert styles and nose radii are available as standard.

Drilling of steel, stainless steel and cast iron is covered by the high-performance range of drills with TiAlN coating.

CERATIZIT UK & IRELAND Ltd
Tel: 0800 073 2073
Email: tony.pennington@ceratizit.com
www.ceratizit.com

Kyocera introduces new innovative tooling solutions

With the new KPK series and the MFWN mini-series, Kyocera is adding two new product lines to its successful cutting tool product lines.

Kyocera is known for its innovative tooling solutions. Long tool life as well as high performance are key advantages of the two new technologies, which extend its existing line. The KPK series is well prepared for high-performance cut-off solutions and strong clamping mechanism for added safety and security. The MFWN mini-series is a smaller version of the original cutters, which also offer excellent performance and tool life.

The KPK series ensures stable and safe cutting

When it comes to cutting operations in general, the workpiece can be difficult to secure which leads to rigidity and chattering issues. Therefore, the cutting speed is usually low at the workpiece rotation centre. Also, tools tend to be broken easily by chip troubles. All these issues are long gone with the KPK series as it features a new insert, blade and a tool block design for rigid, safe and speedy cut-off operations in the fields of steel, stainless steel, cast iron and aluminium. Due to the easy insert replacement, the down time is reduced to a minimum. The firmly secured insert uses three contact surfaces to ensure safe clamping which eliminates chattering completely and makes the cutting-off process a lot safer.

The unique chipbreaker technology is inherited from the KGD line-up and provides excellent chip control. Thanks to this advanced technology, tool life is longer and machining stable. The rigid toolholder block not only prevents chattering but also provides an internal coolant which again



adds to the tool life even under normal pressure.

The MFWN Mini cutters convince like the original

With the low cutting force 90° milling cutter with double-sided 6-edge inserts, Kyocera has launched a new mini-series with a smaller diameter than the original MFWN milling cutters. The new line is based on the original, the MFWN milling cutter, but is in no way inferior to it. On the contrary, the mini-series works at up to 5 mm D.O.C., while the large model can be used at a cutting depth of up to 8 mm. This product is also used for machining materials such as steel, stainless steel, cast iron and exotic materials.

The design is based on the original MFWN series with fracture-resistant inserts, low cutting forces and neutral inserts for various uses. Another plus is the insert lineup. It is comprehensive for various machining applications. In total there are three insert chip breakers and four grades available. Namely for general use GM, for low cutting force SM and tough edge GH. Additional fine pitch and small diameter toolholders are available.

Headquartered in Kyoto, Japan, Kyocera Corporation is one of the world's leading manufacturers of fine ceramic components for the technology industry. The strategically important divisions in the Kyocera Group, which is comprised of 298 subsidiaries, are information and

communications technologies, products which increase quality of life and environmentally friendly products. The technology group is also one of the most experienced producers of smart energy systems worldwide, with more than 40 years of know-how in the industry.

Kyocera Unimerco Ltd. manufactures, distributes and services tools for machining, primarily for the metal, woodworking, automotive, aerospace, power generation and Fluid power industries. The technology centre in Lichfield focuses on effective solutions for production. The tooling concept comprises of standard and customised tools, RE•NEW™ tool maintenance, coating and optimisation guidance.

The Sheffield branch specialises in supplying inserts, standard tools and related tool solutions to the industrial market in the UK, including the general machining, aerospace, offshore and medical industries. The company was established in 1998, services all of the UK and is part of the Kyocera Unimerco group, founded in Denmark in 1964 and originally named Unimerco. In 2011, all activities were acquired by Japan-based Kyocera.

KYOCERA UNIMERCO Tooling Ltd

Tel: 01543 267777

Email: uksales@kyocera-unimerco.com

www.kyocera.co.uk



MAPAL introduces additive to create efficiency

As a general rule-of-thumb, if the weight of PCD cutting tools is reduced, then significantly higher cutting data can be achieved. To realise the benefits of lightweight cutting tools, MAPAL is now utilising additive manufacturing processes; a process that is also providing complete design freedom for ever more innovative solutions. As 3D printed cutting tool structures can be designed and manufactured to minimise weight without compromising strength or integrity, MAPAL engineers are increasingly pushing the boundaries of cutting tool design and development.

New lightweight bell tool with long tool life

An example of how MAPAL uses the advantages of 3D printing can be realised in the company's new bell tools with brazed PCD inserts. Bell tools are frequently used in the hydraulic and automotive sectors, with examples being the external machining of hose connections on turbochargers where complex contour requirements must be met with precision. This means that cutting tool production must be equally precise to ensure customers can achieve their cost-effective, precision machining requirements.

To meet the needs of the end-users, MAPAL has optimised the existing, conventionally manufactured bell tool by integrating selective laser melting process into its manufacturing processes. This allows the inside of the cutting tool to be modified. So, instead of utilising tools with a heavy solid material design, the new tools have now been specially designed with a honeycomb structure. As a result, the tool is at least 30 percent lighter and the tool life is increased by upwards of 40 percent, credit to the enhanced vibration damping characteristics of additive manufactured tool designs. It is therefore possible to machine at higher speeds and feeds while retaining the quality demands that MAPAL end users are accustomed to.

Customers using MAPAL's additive manufactured tools are witnessing productivity improvements in the region of 50 percent. Additionally, company experts are using the 3D printing technology to optimise the cooling channels, ensuring that cutting fluid is delivered to the cutting area via the most efficient possible route. The new bell tool is a hybrid design that can be specified by the end user to meet their exact machining requirements. Using selective

laser melting, the new tool geometry is printed on a highly precise tool body with an HSK-63 connection. The additively manufactured tool body is subsequently machined to provide the precise platform for the PCD inserts to be brazed into place and then cut to shape using a laser.

MAPAL Präzisionswerkzeuge Dr. Kress KG is one of the leading international suppliers of precision tools for the machining of practically all materials. The company, founded in 1950, supplies leading customers from the automotive and aerospace industries and from machine and plant engineering. With its innovations, the family-owned company sets trends and standards in production and machining technology. MAPAL sees itself as a technology partner, supporting its customers with the development of efficient and resource-conserving machining processes using individual tool concepts.

MAPAL Ltd Tel: 1788 574700

Email: sales@uk.mapal.com www.mapal.com



**Now made from sugarcane.
Protective packaging
from rose plastic.**

rose plastic®
innovations in plastic packaging

rose plastic UK Ltd. Phone +44 1709 7217 94 · info@rose-plastic.co.uk · www.rose-plastic.co.uk

Durable components demanded for Bombardier train assembly line

KM Tools Ltd has selected WDS Component Parts Ltd to supply the car body manufacturing facility for its prestigious project for the UK's leading train manufacturer, Bombardier Transportation. WDS has provided component parts for the jigs and fixtures deployed in Bombardier's carbody manufacturing facility by KM Tools. KM Tools made the selection based on product durability, ease of selection and service.

Bombardier's site in Derby is the UK's only train manufacturing facility, designing and building AVENTRA electric multiple unit trains for UK operators. Its carbody facility manufactures key components; the underframe, roof and body sides. Within the welding facility, jigs and fixtures are used to hold the sections of train sub-assemblies in place during the welding process. KM Tools selected WDS to provide a variety of component parts used within the assembly jigs and fixtures based on high product reliability and service efficiency.

"Bombardier is very important for KM Tools because of the scale of the project," says Adrian Degg, engineering director at KM Tools Ltd. "Manufacturing equipment for specialist production lines such as Derby means that we need high confidence in the

components we use in our assembly jigs. Supplying OEM customers like Bombardier, where time to market is key, also means that we need efficient suppliers. We've worked with WDS for eight years and they were our natural choice to provide component parts for this high-profile project."

WDS provided a variety of components for the jigs and fixtures including locating pins, latches, swing clamps, toggle clamps, indexing plungers, hinges, knobs and handles. It's crucial that product quality is high, especially where many of the components are used in demanding conditions on a daily basis, such as indexing plungers. Where extra durability is required, some of the components selected are constructed from hardened materials. Depending on where the component will be used, resistance to corrosion is also important, for example if the area is frequently lubricated and where soap is used to clean lubrication away. For this reason, KM Tools selected stainless or mild steel as the material of choice, chemically blackened where required to increase resistance to corrosion.

"We've always found that WDS component perform impeccably in terms of reliability," explains Adrian Degg. "This is especially important to us and a reason for working with them. Any component failure would risk the uptime of our customers, so it's key for the reputation of KM Tools' as a manufacturer of high-quality equipment."

Stock availability and delivery time is an important consideration for KM Tools, especially when projects involve large OEMs such as Bombardier where higher product volumes can be required for delivery within 24 hours.

"WDS carries a broad stock range and invariably supplies the component we need. Delivery time is very important for us, especially where we may order 100 units of a particular item, and WDS has a stock level which can fulfil our needs," Adrian Degg says.

In order to select the right component, KM Tools' engineers have a complete understanding of their required specification. Therefore, what they need is fast, clear access to component



specification in order to make their choice. Adrian Degg explains that all the information required to make a rapid selection is available on WDS' website, including 3D drawings which can be integrated into KM Tools' equipment design.

"When you're designing an item such as a jig, downloading and inserting the 3D model of the component makes the process far easier and saves valuable time."

Adrian Degg also explains that a reason for choosing WDS is their approach to clear pricing, which makes calculating project costs a faster process, especially where multiple units of a component are required.

He concludes: "Pricing on the website is clear and easy to calculate at outset, which means you don't have to spend time phoning the supplier to find out the best price. Not all suppliers present their costs online and it can save a lot of time, particularly if you need clarity on the cost of 100 units, rather than a single unit or 10."

WDS Component Parts Ltd

Tel: 0113 2909852

Email: aporritt@wdscomponents.com

www.wdsltd.co.uk



Fast and precise component workholding?

The answer's
YES



Chick

from 1st MTA

The UK's leading machining accessory supplier.

Email: enquiries@1mta.com Freephone: 0800 783 0510

Fax: 0800 783 0517 www.1mta.com



Leader offers rapid change results with MicroCentric

Available from exclusive UK and Eire agent, Leader Chuck Systems, the MicroCentric KSF RC (Rapid Change) high precision power chucks offer machine shops a number of advantages. Available in two diameters, the chucks feature MicroCentric's patented Rapid Change Jaw System that can reduce changeover times on CNC lathes and turning centres to an absolute minimum.

Managing director Mark Jones says: "Quick-change chuck jaws make unarguable sense in any high variation workshop production scenario. Simply put, there are only two states a machine tool can be in that really matter to any workshop: in production, making parts, or not. When a machine is making parts, it is making money. When a machine is not making parts, it is costing money. Therefore, any reasonable investment that helps a machine make parts more of the time is going to improve business performance. These MicroCentric chucks fit the 'reasonable' investment profile perfectly."

The KSF-08/RC is a 210 mm diameter chuck with a 66 mm through hole while the larger KSF-10/RC is 254 mm diameter with an 82 mm through bore. Both are rated up to 5,000 rpm and can be specified with A2-5, A2-6 or A2-8 spindle mounting plates.

Featuring a boltless design, the rapid change jaws on the KSF range offers a full jaw area for clamping. Supplied soft as standard, with hard jaws available as an option, they can be exchanged in seconds but remain precise. The KSF chucks have a repeating accuracy of 0.0025 mm, such that when top jaws are finished machined on the chuck MicroCentric guarantee that parts will



run within 2.5 micron radial and lateral TIR if the top jaws are not removed from the chuck. After machined top jaws are removed and then replaced onto the same base jaw they were machined on, a maximum runout of 0.025 mm TIR is guaranteed. A graduated scale engraved into the master jaw facilitates quick precise positioning of the top jaws during changeover.

If a higher level of accuracy is required after top jaws are changed, the radial runout of KSF chucks can be adjusted. Since the spindle adapter mounts to the spindle nose and the chuck then mounts to the adapter plate, the radial runout of the clamped part can be corrected to between 10 and 20 micron by a unique MicroCentric feature. The chucks feature four radial adjusting screws on the outer diameter of the chuck body to achieve this and once the runout of the part has been adjusted the repeatability of the chuck is assured for subsequently clamped parts.

Precision fit master jaws minimise lift with a wedge design securely pulling the jaw down onto precision serrations. Pitched at 1.5 mm, the serrations aid the extremely quick location of each of the three jaws. While hardened chuck bodies, actuators and master jaws ensure long-term accuracy and performance.

Mark Jones puts the investment into perspective: "Say your machine time is charged out at a very reasonable £40 per hour and it takes half an hour to change jaws

on average, that means a jaw change costs you £20. However, MicroCentric's Rapid Change Jaw System cuts the time to under five minutes. This means you get back at least an extra £15 worth of machine time with each jaw change and that is per machine. Add up all the jaw changes over the course of a year and you will be surprised just how big that number gets."

He concludes: "Unlike competitive quick-change jaw systems that feature relatively expensive replacement jaw sets, MicroCentric is going to keep the cost of the jaws reasonable so there is no cost penalty for workshops looking to access the benefits available."

Founded in 1969, MicroCentric has, for nearly half a century, been advancing engineering and high-quality manufacturing. This has earned the company the reputation of being one of the global leaders in precision workholding technology. Each MicroCentric product is backed by superior design, the highest quality materials and precision workmanship for reliable, long-term performance and unmatched accuracy.

Leader Chuck Systems Ltd

Tel: 01827 70000

Email: mjones@leaderchuck.com

www.leaderchuck.com



Stocdon introduces CentroLite

The small Allmatic Centric vice range

These modular centric clamps are produced on demand with a high degree of automation and with the user in mind. AllLite achieves this through improved designs and manufacturing processes that meet industry standards 4.0. This is how AllLite is focusing on demand, especially from single and small series production as well as from companies with market-leading automation solutions.

Less is often more

Not every machining company requires complex clamping systems with as many different applications as possible. On the other hand, numerous companies require machine vices with only a few, but precisely defined, performance features.

CentroLite clamping systems from AllLite are accurate and cost-effective. Without compromising on performance, CentroLite gripping provides a clamping force of 28 kN for excellent value, without pre-embossing.

CentroLite is a flexible, powerful clamping system, which is easily and quickly configured and available from Stocdon.

Avantec

Metal removal at the spindle is all about Q. Avantec processed seven steel elements on their training and demonstration unit to show you the benefits.

Put together, they form the letter Q which is the symbol for the formula used to calculate the chip volume per time unit. This "Q" symbolises the Avantec guiding theme: to always achieve the maximum chip volume Q in addition to highest precision, perfect chip flow and long tool life. The outstanding feature of every Avantec milling cutter.

Eleven Avantec milling cutters have taken a part as a sample of the complete Avantec tool program. From extreme heavy-duty machining to high feed copy milling to finest surface finishing, pockets, grooves, chamfers and contours. In performing its specific processing operations, each tool has done its best; its maximum Q.

Industry and workpiece specific standard tooling and custom-tailored machining solutions. Avantec milling cutters set the benchmark in high volume machining, choose maximum Q and highest precision.



Stocdon is always at your service and will be happy to advise you on your specific task at hand. The first priority is the solution, then the Avantec tool; what follows is your success.

Stocdon will help you engineer the perfect Avantec solution for your applications.

Stocdon

Tel: 01242 241123

Email: contact@stocdon.co.uk

www.stocdon.co.uk

Fail-safe pneumatic swing clamps

In Roemheld's new pneumatic swing clamps, a mechanical lock ensures that the clamping force is maintained even when the pressure drops so that the workpiece remains safely in position.

Roemheld UK has introduced pneumatically actuated swing clamps incorporating a mechanical locking action, whereby the full holding force, between 200 and 600 N, is maintained in the case of air pressure reduction or loss, ensuring operator safety and avoiding the production of scrap. Operating pressure is between two and six bar.

The clamp is a pull-type cylinder with a piston that is automatically locked when the workpiece height is within the designated clamping range, after which the air line can be depressurised or uncoupled, for example during pallet change. For unclamping, which is monitored, only the minimum pneumatic pressure is needed.

A feature of the clamps is a pair of flow control valves that can be easily adjusted from above. They allow the speed of the

sturdy swing mechanism to be reduced if the flow rate is too high or when the clamping arms are of larger mass. It also enables synchronisation or sequencing of the closure of several connected clamps. Swing angle is normally 90 degrees clockwise or counterclockwise, although it can be 60 degrees, 45 degrees or absent, 0 degrees.

If machining dry or with minimum quantity lubrication, the ingress of small particles can be prevented by the use of an additional wiper ring.

Roemheld (UK) Ltd was founded in 1975 to supply innovative workholding solutions to the UK and Ireland. From its base in Hertfordshire, it is proud to provide workholding and materials handling solutions to a wide range of companies from large OEMs down to the smallest of machine shops.

It provides sales, service and ongoing technical support to customers across varied industry sectors and is involved in training programmes designed to support the next



generation of engineers. The company uses its own products within its own manufacturing processes, ensuring it is well placed to understand the changing demands of the marketplace.

Roemheld UK

Tel: 01462 459052

Email: sales@roemheld.co.uk

www.roemheld.co.uk

ACE Ceiling Products completes prestigious projects with help from Lantek

ACE Ceiling Products has been manufacturing bespoke sheetmetal components since the early 80s and is a leader in its specialist field of bespoke construction projects and ceilings. A step change in its business was the introduction of Amada CNC punching machines in 1998, enabling it to produce micro perforated sheets which have 1.5 mm diameter holes at 2 mm pitch, widely used in the industry for specialist ceiling tiles.



and images are discussed with the architect before a full-size mock-up is built, working through to final approval of the designs. At this stage, installation is put out to tender and ACE Ceilings can start full scale manufacture of the component panels required in the project.

Some of the major projects the company has been involved in include the new Tottenham Hotspur stadium opened in 2019, Goldman Sachs headquarters in London and redevelopment of the ceilings in disused platforms and tunnels at Waterloo station ready for reopening.

90 percent of ACE Ceiling Products' work goes through the Lantek software. Much of the project work requires parametric design of families of parts. The flattened component parts are then imported into Lantek Expert. Nesting is carried out according to material type and thickness, mixing parts from different jobs on the same sheet.

Damian Jones continues: "All the parts are brought into the software and nested as a collective. We may have 100 parts which are auto nested together and then auto-tooled. We may then have 20 sheets or more to make up the workload. Parts are tagged into the sheet and we identify them



with a series of small holes which make up a code for each part number. The auto-tooling is very good, making the process automatic, while the auto nesting has generated savings of around 15 percent in material usage despite our panel parts being large and difficult to nest efficiently."

Lantek is currently developing some macros for ACE Ceiling Products to help it in the manufacture of specific families of parts.

The company, based in Coventry, now has three Amada punch presses, a Vipros 355 and 368 and a 2510 with automated sheet handling. It uses Lantek Expert to efficiently nest parts and auto-tool all the punching operations. Damian Jones of ACE Ceiling Products says: "I had known about Lantek Expert for a long time and, when we looked at it in detail, its ability to work with 3D models and parametric designs was impressive. Introducing the software has led to a 90 percent reduction in our CNC programming workload."

Working closely with architects, ACE Ceiling Products gets involved at the concept stage of the project, helping to turn the architect's designs into reality with advice on how they can be manufactured and assembled. 3D models of the concept with rendered images are built in ACE Ceiling's Creo CAD software and proposals



Damian Jones adds: "We now have spare capacity thanks to the Vipros 355 and 368 machines and the 24-hour unmanned operation capability of the Amada 2510. Lantek has been a vital part in making this possible as its automated programming and nesting has given us the capability to use the machines to their full capacity. We are now ready to expand our business for the future benefit of our customers."

Lantek is a multinational which is leading the digital transformation of companies in the sheetmetal and metal industry. With its patented manufacturing intelligence software, it enables factories to be connected, turning them into Smart Factories. It rounds off its range of services with CAD, CAM, MES, and ERP solutions for companies that manufacture metal parts from sheetmetal, tubes and profiles using any cutting technology; laser, plasma, oxycut, waterjet, shearing and punching.

Founded in 1986 in the Basque Country, Spain, one of the main European hubs of machine tool development, Lantek enables the integration of sheetmetal and metal processing technologies using the most advanced manufacturing management software.



The company is currently the outstanding leader in its sector as a result of its capacity for innovation and commitment to internationalisation. With more than 23,700 customers in over 100 countries and 20 offices in 14 countries, it has an extensive network of distributors with an international

presence. In 2019, its international business contributed to 86 percent of its revenue.

Lantek Systems Ltd
Tel: 01684 585384
Email: rob.powell@lantek-systems.co.uk
www.lantek-systems.co.uk

Bringing further automation to nesting and NC code generation

JETCAM has announced version 3.57 of its JETCAM Orders Controller (JOC) nesting automation software, which includes a raft of new features.

Available in two versions, Premium and Premium Automation (PA), JOC works in conjunction with JETCAM Expert nesting software to streamline and automate the CAD import and nesting process.

JOC (PA) now fully automates CAD import, whereby a folder can be monitored for a CSV file containing details of DXF files to process, material, thickness, quantity required and machine to nest for. An existing system such as CAD, MES or MRP could generate a CSV file that would be immediately imported, tooled for multiple machines and nested with NC code being available within minutes and all completely without any user intervention.

The setup section within JOC has been completely restructured in line with JETCAM's enterprise manufacturing suite, CrossTrack. An expandable tree in the left of the screen provides logical access to all settings, whilst a new pane on the right provides detailed descriptions and

examples of use of each setting. Any errors in the settings are highlighted at the top of the screen, allowing users to quickly identify and fix issues.

Order priority for nesting can now be automatically set for an entire list of parts based on the column selected, such as assembly sequence, material or thickness.

This is an alternative to progressive nesting, which groups items by kit or order ID and will produce a nest where the order of nested items is sequential, trading nesting efficiency for much faster unloading.

A new copy/mirror function provides the ability to create copies and/or mirrors of existing components, automatically tooled and ready for nesting on multiple machines.

Users now also have the option to generate NC code for additional machines automatically when sending parts for nesting.

A number of background services have been added. Users can now create multiple configurations using the same software

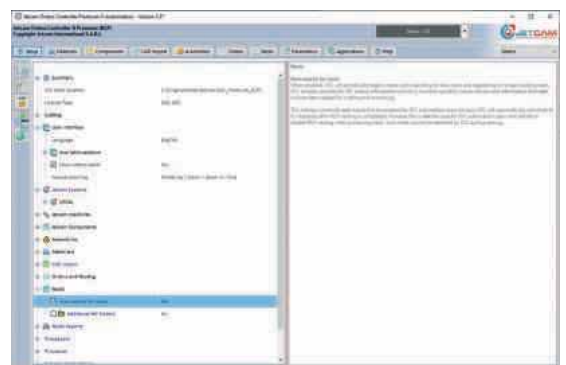

installation, which is useful for testing new features. Support logging creates a detailed log so that in the event of any problems, such as network or permissions issues, these can be highlighted.

Existing customers under maintenance can download JOC for free. Videos covering the new features are available online in the JETCAM University.

JETCAM International s.a.r.l.
Tel: 0870 760 6469
Email: info@jetcam.com
www.jetcam.com

Eagle uses HP Jet Fusion 3D printer for premium quality Jaguar car parts

Eagle, a restorer of the legendary Jaguar E-Type car, has announced a partnership with Graphite Additive Manufacturing Ltd to use HP's Jet Fusion 4200 3D printing solution to produce custom parts. Eagle has already seen a huge increase in quality, cost-effectiveness and efficiency since switching to HP's 3D printing from other 3D printing processes.

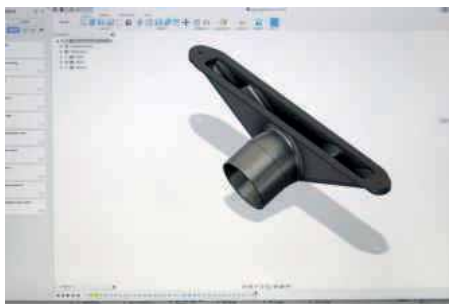

Eagle deals in only one car: the luxury Jaguar E-Type. Since it was founded in 1984, the company has made a name for its own "Eagle E-Types", which are meticulously restored over the course of about 4,000 hours. Eagle re-manufactures the E-Type to a modern-day standard of quality that has resulted in BBC's Top Gear referring to it as "probably the best built handmade car in the world."

For the past four years, Eagle has worked closely with Graphite Additive Manufacturing Ltd, a UK-based 3D printing service provider which produces one-off models or production runs of functional parts for businesses and individuals. Since using HP's advanced 3D printing platform for the air conditioning and heating air ducts within its E-Type cars, Eagle has benefitted from a significant reduction in turnaround times, streamlined processes and greater flexibility to meet customers' unique demands.



"Since we began using HP's 3D printing technology for production, we've been impressed by the improvement in how these parts look as well as their durability," says Paul Brace, director at Eagle. "HP's 3D platform consistently delivers the desired finish which is very important to our process. The heating ducts need to be attractive enough to sit on the dashboard, and these parts match the exceptional quality of our classic cars. Additional benefits we've seen include the wider scope for shapes that we can now create using 3D printing, and the weight reduction in materials on offer. This adds value for customers who are keen to keep parts as lightweight as possible."

Whereas with previous 3D printing technologies, Graphite Additive Manufacturing Ltd. had to mix materials and load the machine by hand, HP's 3D printing solution simplifies workflow with automated material mixing and loading systems, cutting down an entire day's work into a period of 30 minutes.

A key challenge for Eagle was its low volume component requirements, as the business only creates four to five E-Types per year. On top of this, there are five model variations, each being either left or right-hand drive with entirely different technical specifications. This means that certain bespoke parts are used in very low numbers, perhaps even just one per year. Normal manufacturing methods such as

laser cutting, machining and moulded parts require production of a reasonable quantity to be economically viable.

HP's 3D printed parts allow Eagle to produce in low volumes with design and economic advantages, as the digital 3D model is easily adjusted and the final part swiftly printed. This means that, if required, every part can be an evolution of the last with no cost implication from the change other than the shipping.

"The capabilities of HP's 3D printing solutions are ideal for the production of custom-made, high-quality car parts provide a host of solutions for the automotive sector, and we're excited to see how it helps shape the future of car manufacturing in the coming years," comments George Brasher, UK&I managing director at HP. "It's exciting to see Eagle's commitment to innovation as they take advantage of the efficient, flexible design and customisation enabled by HP 3D solutions for its market leading bespoke vehicles."

The HP Jet Fusion 4200 3D printing solution offers customers an easy-to-use solution that scales with its business and enables an integrated, end-to-end process that delivers both functional prototypes and final parts.

HP Inc UK Ltd
Tel: 0207 6606027
www8.hp.com

Bernard Holmes continues to benefit from modularity of PSL Datatrack

Bernard Holmes Precision Ltd initially invested in PSL Datatrack production control software in order to streamline their entire production process from initial quotation through to final invoice. The decision was based on the desire to acquire ISO 9001 as many customers were demanding that their major supplier of subcontract engineering services should be accredited. Production director Russell Thackray had recognised that the company's manual paper-based administration systems were simply not up to the required level to achieve the accreditation.

Some seven years later, the company can look back with pride on having achieved ISO 9001, just four months after implementation with zero non-compliance and also on the way it has developed in the intervening years. The goal of attracting more work from larger organisations in different industries continues to be successful and today the company has 18 CNC machines alongside a busy manual machine shop. PSL Datatrack remains at the core of the company's success.

Continuous investment in the software has seen Bernard Holmes extend its initial PSL Datatrack sales and invoicing modules into an all-embracing package that helps run the business. Job costing and Shop Floor Data Collection (SFDC) were added back in 2014, with Gauge Calibration added more recently in 2019. Supplier and Works Non-Conformance may be added in the future to enhance quality assurance.

Russell Thackray says: "One of the attractions of PSL Datatrack has been the fact that you can add additional modules whenever you need them and know that they will be compatible with those that you already have. The software grows with us and helps us to take the business forward."

Although PSL Datatrack is essentially an off-the-shelf system, the adage that there is not one system in use that is the same as another is also true, owing to the customisation that is readily available for any aspect of the software's functionality. This includes custom reports and documents. For example, there are different styles of invoice for different Bernard Holmes customers and sometimes a customer can request



something specific: "We have a customer who likes to see the cost of individual parts on our goods delivery notes, so the price can be checked as they are booked in. PSL Datatrack can easily accommodate that type of request," concludes Russell Thackray.

PSL Datatrack
Tel: 08456 345931,
Email: sales@psldatatrack.com
www.psldatatrack.com

Renishaw joins project to automate additive manufacturing post-processing

Global engineering technologies company Renishaw is collaborating with UK start-up business Additive Automations, as part of a project to automate metal Additive Manufacturing (AM) post-processing, which involves using collaborative robots, cobots, to perform support structure removal. The project could reduce the average cost per part by 25 percent, furthering AM's potential as a cost-effective option for large volume production lines.

Additive Automations is a Sheffield-based start up that creates robotic systems to automate AM. After obtaining funding from UK and Canadian bodies, its founder and CEO, Robert Bush, collaborated with both Renishaw and the University of Sheffield Advanced Manufacturing Research Centre (AMRC). Since August 2019, Renishaw has been assisting Additive Automations' progress by providing its industry leading AM expertise.

Renishaw provided four examples of AM builds, so the start-up could demonstrate its support structure removal system. The four AM parts were designed for medical, oil and gas, automotive and mechanical

engineering applications. Testing its robotic system on parts already being used in industrial applications will help Additive Automations demonstrate the potential of its product.

The project, named Separation of Additive-Layer Supports by Automation (SALSA), aims to use robotics and deep learning to digitalise some of the few remaining manual processes left in AM. Cobots were chosen for their high payload-to-size ratio and integrated force sensors, which collect data to determine the geometry of AM parts. Software then analyses the data, using digital twin technology. The output is then used to determine where the support structures are so that they can be removed using an end-effector tool.

"Automating support removal and finishing in AM completely changes the economics when scaling up AM and, for the first time, makes it feasible for manufacturers around the world to adopt this technology in rapid production," explains Robert Bush. "The digitalisation of AM also comes with an increase in quality,



traceability and repeatability. Given that on average almost two thirds of post-processing costs are from finishing and support structure removal, we believe automation can reduce costs by an average of 25 percent per part."

"Improvements in post-processing could bring AM to the forefront of new applications in medical and aerospace applications," adds Bryan Austin, director of AM Sales at Renishaw. "An automated manufacturing process could make AM adoption more appealing to manufacturers operating large volume production lines."

Renishaw plc
Tel: 01453 524524
Email: uk@renishaw.com
www.renishaw.com

OPEN MIND does a good turn for subcontractor

Located near Nottingham City centre, Doosan Precision Engineering specialises in CNC turning and milling, producing parts for industry sectors so diverse that the small business covers everything from motorsport to the food industry.

Founded in 2010, the small business has grown rapidly by investing in a diverse range of machine tools with multi-axis capabilities to produce parts in one hit.

Although no relation to the Doosan machine tool brand, the company has invested heavily in the Doosan machines from Mills CNC. The company name is a culmination of directors family names. The ISO: 9001 certified company has a plant list that includes a Doosan DNM 500 machining centre with a 4th-axis, plus five turning centres that includes the Doosan Lynx 300M, Doosan LYNX 220LM, two Doosan LYNX 220 LSYC machines and the newest arrival, a 9-axis Doosan MX2100ST. As a machine shop primarily conducting turning activities, Doosan Precision Engineering is not a facility where you would typically expect to find hyperMILL®, the industry's leading 5-axis CAM software from OPEN MIND Technologies.

David Booth from Doosan Precision Engineering Ltd says: "We were spending a long-time setting-up some quite difficult parts with some very intricate setups to cater for difficult features that we are machining. This was the reason we initially looked at hyperMILL from OPEN MIND. The prolonged setup times were increasing our costs and we were losing work, some of this was going overseas. Since we invested in hyperMILL, we have managed to win this business back."



Referring to how hyperMILL has revolutionised the business, David Booth continues: "hyperMILL has reduced the setup times massively. Some parts were taking four to five hours to program and set, the new CAM system has now reduced this to as little as 30 minutes in many cases. OPEN MIND is well respected as an industry leader in 5-axis milling technology, but we specifically bought it with turning in mind. We have one part that was originally manufactured using grooving tools to machine the scallop at the back as well as other features. Unfortunately, the challenging material demonstrates poor swarf control, now we use hyperMILL, we can use a single button tool and the job comes off the machine completely finished."

"The decision to use this single tool configuration was decided by hyperMILL CAM software. The software selected the best strategy to control swarf and reduce the cycle time, which reduced massively when compared to the previous value."

With regard to the programming and the cycles, David Booth adds: "Essentially, our customers provide us with drawings from the most of the common file types and we feed this into the CAM software. Providing we know and understand the cycles, hyperMILL spits out a finished program. That really is about as difficult as it gets. The code generation is straight off the CAM model and is straightforward."



He concludes: "We did the three-day training course at the OPEN MIND UK facility in Bicester, which was primarily focussed upon milling with some turning aspects. However, the system is intuitive and easy to pick up from scratch. We have now won back all of the work that we initially lost. hyperMILL will certainly pay for itself in a short period of time. Of course, we also use it for all of our milling machines. The reduction in setup times has been a huge benefit to us. The ability to sit down for 20 to 30 minutes and have a finished program is a foreign concept when we compare it to what we used to have. Previously, programming was taking hours and this was a real bottleneck."

OPEN MIND Technologies
Tel: 01869 290003
Email: adrian.smith@openmind-tech.com
www.openmind-tech.com

MSC supports CloudNC in aim to deliver the future of manufacturing

MSC Industrial Supply Co. (MSC) is supporting autonomous manufacturing disruptor CloudNC in its objective to revolutionise the subcontracting market.

MSC has been appointed by CloudNC on a two-year contract covering vending solutions across metalworking and maintenance, repair and operations (MRO) categories. MSC will also provide engineering support to identify and deliver cost down efficiencies for CloudNC.

Founded in 2015, CloudNC is on a mission to transform subcontract manufacturing activities. The UK-based precision engineering firm has introduced a pioneering artificial intelligence (AI) approach to manufacturing, using highly advanced CNC programming capabilities.



The entrepreneurial business has ambitious growth plans for the future having secured government grants and venture capital funding and plans to open manufacturing plants around the world, which will automate and streamline the precision manufacturing process.

MSC will initially support CloudNC at Factory 1, in Chelmsford, Essex, which is the first CloudNC factory. The state-of-the-art facility embraces robotics and Industry 4.0 principles of connectivity and automation to deliver faster, more reliable and more cost-effective CNC machining.

Theo Saville, co-founder and CEO of CloudNC, says: "The MSC team shares our vision for an autonomous manufacturing future and has worked with us to develop a tool management system to help achieve this. We look forward to the integration of this tool vending solution into our factory operating system, bringing autonomous software control to another key aspect of the precision manufacturing process, to drive faster turnaround and even lower prices for our customers."

Alasdair McCallum, regional sales manager at MSC, says: "We look forward to supporting CloudNC in its ambition to automate and advance manufacturing processes by delivering our first-class engineering and technical support and cost-saving solutions."

MSC Industrial
Tel: 0121 5059500
Email: sales@mscdirect.co.uk
www.mscdirect.co.uk

CloudNC
Tel: 020 39665860
Email: hello@cloudnc.com
www.cloudnc.com



Make Production Smarter

Hexagon offers a range of CNC simulation software, factory automation solutions and computer-aided manufacturing (CAD / CAM) packages specifically for various production methods.

| Visit hexagonmi.com



RADAN's winning move for TCI

Before investing in RADAN CAD/CAM software, creating manual nests took a sheet metal fabricator several hours, meaning shop floor staff moved on to other tasks while the nests were generated. But now a day's worth of nests are produced in just a couple of minutes.

"This makes a huge difference to us," says Tindle Construction Inc's engineering manager Jesse McGinnis. "We have an employee who only programs for half the day, freeing him up to spend the rest of the time on engineering projects. Because of what we're able to do with RADAN, it's not necessary to have anyone generating nests full time anymore."

Continuous improvement has always been the goal at Tindle Construction Inc (TCI) where industry expertise and the implementation of efficiency-boosting technologies has helped the company create high-quality products since 1994.

Headquartered in Fredonia, Kansas, TCI is a family-owned, multi-divisional company regarded as the premier metal fabricator and specialised industrial services company across the USA. Operating across two divisions, industrial services and fabrication, the company produces products for a variety of customers, along with design and planning services.

Jesse McGinnis says some of the aspects that separate them from their competitors include AWS certified and R-stamp welds, custom engineering on architectural parts and custom high-end finishes on copper, brass, stainless and carbon display products.

TCI's diverse range of fabrication capabilities include ornamental and architectural metal products, signage and artwork, as well as sheet-metal products like wall panels, corner trims and ceiling inserts are counted. Sheet metal parts, weldments, structural steel, pressure vessels, and unique

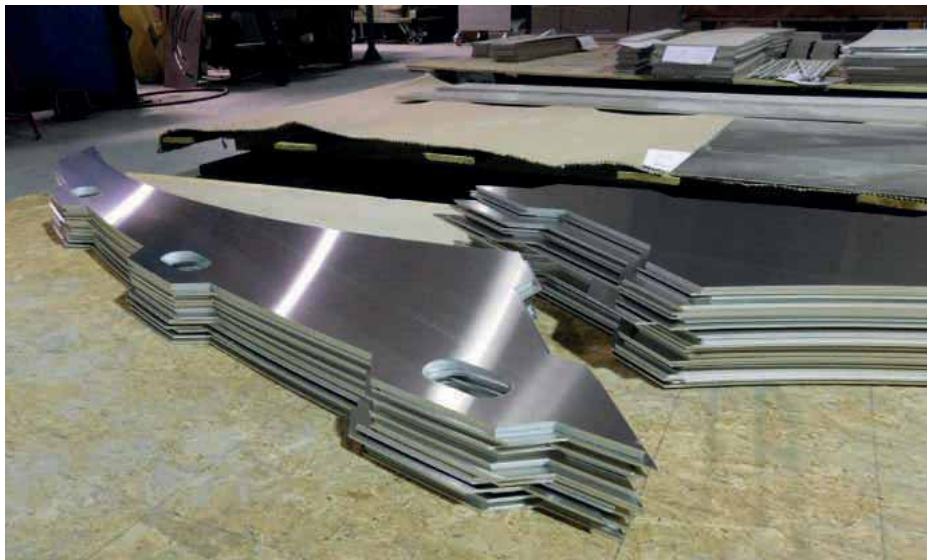

metal finishes are typical projects that make their way across the shop floor. Aluminium, carbon steel, stainless steel, brass and copper are TCI's most commonly used materials.

"We have a lot of different machines with a lot of different capabilities and combining those is like playing chess," says Jesse McGinnis. "It's interesting to see what we can come up with to get the job done and that's definitely a challenge I enjoy."

TCI utilises a laser, waterjet, press brake, mandrel bender, CNC lathe, CNC mills and manual lathes and mills. Part of his job is to decide which combinations of machinery will be most efficient and best suited to each unique job.

He was hired by TCI specifically for the fabrication side of the business and was tasked with hand-programming the company's latest laser. TCI eventually invested in a CNC programming solution for the laser, but over time found that the system was significantly limited in efficiency and flexibility. After investigating all options for implementing a new sheetmetal solution, TCI made the switch to RADAN. "I felt like RADAN was a better fit for us," says Jesse McGinnis, who also uses RADAN to program TCI's waterjet.

Unlike many other solutions for sheet metal, he says RADAN also allows them to edit the automatically-generated nests, ensuring that programming control remains in their hands: "The ability to edit nests was something that our old software couldn't give us, but with RADAN we can edit the



lead in, lead out tooling, or just edit for cosmetic reasons."

He concludes: "We wouldn't be as efficient as we are without RADAN's nesting and the system's ability to do what we need."

Hexagon is a global leader in sensor, software and autonomous solutions. It puts data to work to boost efficiency, productivity and quality across industrial, manufacturing, infrastructure, safety and mobility applications.

Its technologies are shaping urban and production ecosystems to become increasingly connected and autonomous, ensuring a scalable, sustainable future.

Hexagon's Manufacturing Intelligence division provides solutions that utilise data from design and engineering, production and metrology to make manufacturing smarter.

Hexagon Manufacturing Intelligence
Tel: 01242 542040
Email: enquiry.uk@hexagonmetrology.com
www.hexagonmi.com



Bounce back with VERICUT

CGTech, the developer of VERICUT CNC simulation, verification and optimisation software, has announced new financing options to help manufacturing businesses get back up and running during the ongoing COVID-19 pandemic.

In the current climate budgets are tighter than ever before, customers are demanding more for less and so investing in new software may not be top of the agenda. In an effort to help machine shops get back up and running quickly and efficiently, CGTech has launched a new WorkSmart finance scheme which will allow businesses to install VERICUT for an affordable monthly cost.

VERICUT simulates all types of CNC machining and operates independently, but can also be integrated with all leading CAM systems. The software eliminates manual prove-outs, ensures machining is collision free and increases machine capacity. The latest release, VERICUT 9.1 truly raises the bar for CNC simulation with several new cutting-edge features that increase efficiency and empower users to do more in

less time. The WorkSmart finance scheme is available to new and existing customers interested in adding optimisation capabilities to their VERICUT package. VERICUT Force optimises feed rates and cutting conditions to deliver faster NC programs, with cycle time reductions of 15 percent, 25 percent or more, longer tool life and better part quality.

Tony Shrewsbury, CGTech Ltd managing director, comments: "As well as instantly boosting productivity and improving efficiency, machine shops can avoid a large initial outlay by spreading the cost of VERICUT across low, manageable fixed monthly payments. This will enable them to retain much needed cash."

With various options available, the terms of the scheme can be adjusted to suit all budgeting needs.

"Customers will also benefit from tax savings as repayments are 100 percent tax deductible unlike traditional capital expenditure," concludes Tony Shrewsbury.

CGTech's VERICUT software is the

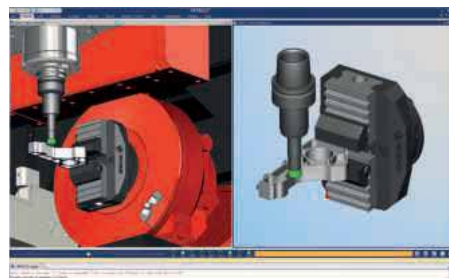

standard for CNC simulation, verification, optimisation, analysis, and additive manufacturing. It also offers programming and simulation software for composites automated fibre-placement, tape-laying and drilling/fastening CNC machines. VERICUT software is used by companies of different sizes in all industries. Established in 1988 and headquartered in Irvine, California, CGTech has an extensive network of offices and resellers throughout the world.

CGTech

Tel: 01273 773538

Email: info.uk@cgtech.com

www.cgtech.co.uk

MIETrak Pro: The complete production control solution...



...for the Manufacturing and Engineering Industry

Contact us for a free no obligation demonstration
01527 576444 sales@mie-solutions.co.uk

mie solutions™
MRP Production Control Software

www.mie-solutions.co.uk

SigmaTEK elevates business systems suite to Version 20

SigmaTEK Systems, a leader in developing CAD/CAM software solutions for the fabrication industry, is pleased to announce the addition of its Business Systems Suite integrated alongside the flagship SigmaNEST product portfolio in Version 20 Service Pack 2 (SP2). This latest release of advanced CAD/CAM, Shop Floor Control and, now, Business Systems, brings a full range of fabrication optimisation and data management features inside one familiar user interface.

Familiarity and ergonomics play a large part in programming speed and user ease. The version 20 user interface employs greatly improved navigation and a universal easy-reading display throughout all SigmaTEK products to increase user focus and stamina.

SigmaTEK's new quoting tool, SigmaQUOTE, is available as both a freestanding application for the quoting department as well as an add-on module for SigmaNEST programmers. SigmaQUOTE uses the SigmaNEST nesting engine, part database, and costing parameters to deliver accurate quotes after a speedy import of part geometry. Full bi-directional integration with SigmaSUITE products offers greater flexibility for a real-world production workflow. Quote workspaces can be modified after job creation and parts can be added, removed and even re-nested without recreating or reimporting the quote, then pushed directly into production work orders.

As the core of SigmaTEK business system products, SigmaMRP provides single-source job management throughout manufacturing, from quotation to delivery and invoicing. SigmaMRP integrates with both SigmaSUITE products and other business systems to administer critical business data.

SigmaMRP's scheduling engine provides better performance for jobs with complex assemblies and sub-assemblies, in addition to subcontract operations. New time controls offer scheduling flexibility around work shifts and employee break periods.

The logistics module streamlines a myriad of shipping details such as cost, markups, and taxes with automatic cost calculation



based on weight of line items in each job. Support for multiple couriers allows individually configured rates for each chosen carrier.

The fully featured inventory module now allows allocation of material and stock per BOM item for improved granularity, as well as allocation by batch for greater flexibility. Complete integration with SigmaNEST ensures stock is dynamically adjusted when programs are posted, deleted, or updated mid-production.

New developments in SigmaTEK shop floor offerings increase the capacity for operators to make the right call on the spot, with access to part documents, or the option to book remnants and sheets back to inventory, or create a new job for rejected parts. SigmaLIFT paperless tracking software is now a web application allowing flexibility for remote barcode scanning, and a redesigned display that shows all available batches for transfer.

SimTrans works in the background to create a seamless data link from SigmaTEK applications to sales, inventory, engineering, scheduling, production and MRP or ERP systems. SimTrans supplies data to business systems at different phases of the order process, such as work order completion, material consumption levels, and automatic machine operation using batch operations.

In the latest release, CAD/CAM products have added profiling and tooling features, and batch commands for work efficiency and increased machine support. Enhancements for SigmaBEND include improved bend ID and sequence change information, additional support for Accurpress press brakes and batch commands for part processing and press

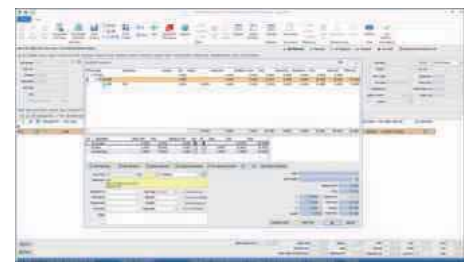
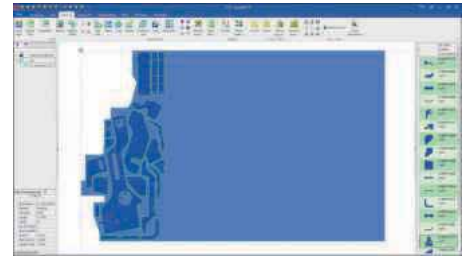

brake part reports. SigmaCTL and SigmaDEVELOP have both been updated with user enhancements which include improved GUI side panels for all shapes from within the 'Pipes with Taps' section and significant batch capabilities to support part quantity in automation, stock list management and program posting.

SigmaNEST CAD/CAM developments include added support for ramping when using 3D bevel technology, measuring capability while in assembly mode, support for the latest CAD versions within the CAD Import Plus modules and significantly improved batch processing performance as more parts are added to the SigmaNEST workspace.

Headquartered in the USA, with branches in Europe, Asia, Australia, Africa and South America, SigmaTEK Systems is a leading global provider of innovative end-to-end CAD/CAM software solutions.

Its customer focus is supported by a worldwide team of consultative professionals and experienced product experts and its industry focused product portfolio helps fabricators increase ROI by optimising material utilisation, machine motion, manpower and data management.

SigmaTEK Europe Ltd
Tel: 024 76 982299
Email: marc.freebrey@sigmanest.com
www.sigmanest.com

Tebis offers best practice

While Tebis is well known as a premium CAD/CAM and MES software company that offers advanced solutions for model, pattern, die and mould making as well as component manufacturing, it also helps customers to standardise their CNC processes and to automate their CAM work.



Joe Zhou, managing director at Tebis UK explains: "Manufacturing process should be consistent and reliable. This is where Tebis can help companies by standardising their CNC processes and

automating their CAM work. The best practise of a company can be built into Tebis library database which can then be shared and reused for a daily operations. This will help to optimise uses of machine capacities and cutting tools as well as to optimise the machining processes and machining parameters."

Tebis works together with customers to define goals and to achieve them, with experiences of hundreds of projects done worldwide. For the outstanding work in this area, Tebis won Top Consultancy Awards in Germany for both 2017 and 2018.

Tebis CAD/CAM software provides five database libraries to store manufacturing information: Virtual machines with clamping devices, cutting tools with advanced machining parameters grouped for different materials and different machines, geometric features associated with machining features, machining cycles and machining processes.

Joe Zhou says: "Tebis is very advanced, comparing to most CAM packages, which utilises colour scheme and layer information to match CNC machining processes to automate CAM work."

The libraries contain standardised processes for fast programming times through automation while also ensuring consistent quality. Traditionally, CNC machining processes are programmed by CAM engineers with interactive operations of CAM software. While this requires highly skilled CAM engineers, CNC machining processes are dependent on individual CAM engineers and the machining results may vary from one to another.

Tebis CAD/CAM software not only provides five database libraries to store best practice machining data but also provides advanced tools to manage the database libraries.

Joe Zhou concludes: "The benefits of having these five libraries are to ensure consistent high-quality results by optimising and standardising the manufacturing process. By adopting CAM automation, work pressure will be reduced along with CNC and CAM work costs. CAM automation also helps to reduce new CAM engineers' learning curve and relieves skills shortage."

Tebis (UK) Ltd
Tel: 02476 158178
Email: info-uk@tebis.com
www.tebis.com

VERICUT®

WE CAN SHRINK YOUR CNC MACHINING COST



VERICUT REDUCES THE COST OF CNC MACHINING

In today's competitive manufacturing environment, software verification is essential to your ability to produce on-time, high quality parts at a minimum cost. With VERICUT you can run a part on an unmanned machine and be confident that it will be right the first time, every time.

Visit www.cgtech.co.uk to learn more

Right first time. Every time.

Curtis House, 34 Third Avenue, Hove, BN3 2PD
 +447 (0)1273 773538 info.uk@cgtech.com

CGTECH.co.uk

Shaping laser metal marking technology for diverse applications

Although laser technology is already firmly established as a reliable and cost-effective process for marking metal components, the areas of application continue to expand as the flexibility of the laser is recognised by increasing numbers of component and product manufacturers.

Each application has its own individual requirements, depending upon the different metal types and the individual size and shape of the part. This means, that while the laser process is applicable to all of the different tasks, the configuration of the system may be different ranging from a relatively simple stand-alone flat-bed type system to a system which is part of a fully integrated manufacturing line.

As a UK representative and distributor for some of the world's leading laser manufacturers, Bromsgrove-based TLM Laser is able to offer a wide range of systems and configurations for metal marking. In this article by the company's Andy Toms, he outlines just a few examples of the different metal marking solutions which they are able to offer to UK manufacturers.

Lasers are capable of marking virtually all metals including stainless steel, high-grade steel, carbon steels, copper, iron, magnesium, aluminium, brass, titanium and of course precious metals. However, as for most manufacturing processes, there is no "one size fits all" solution for laser marking metals.

Lasers mark metals by changing the appearance of the surface and in direct laser marking, the laser energy heats the metal surface causing it to oxidise and therefore darken to produce an indelible mark. For coated metals, such as anodised aluminium,



the laser creates the mark by removing this surface layer. The type of metal being marked, and whether it is coated or not will influence the choice of laser source fibre or CO₂. Today, fibre laser technology is by far the most efficient and effective way to mark metals and, as the UK's partner for FOBA and Universal Laser Systems marking technologies, TLM is able to offer a wide selection of configurations to suit different application requirements.

Understanding that each customer and every application will require a unique approach means we have built up a comprehensive portfolio of modules and systems to ensure that we are able to offer the optimum solution every time. Laser marking machines, such as FOBA's M2000 and 3000, offer stand-alone laser class 1 operation. The ability to configure these machines with a choice of laser powers, rotary tables, axis systems and machine vision options means that the system can be tailored to the exact needs of specific and sophisticated applications.

For applications where the laser needs to be an integral part of a manufacturing system, perhaps where components are being automatically transferred from one station or process to another, FOBA's powerful Y-Series fibre laser's offer a flexible part marking solution.

This series of lasers are suited to almost all metal processing industries and applications

offering precise and efficient direct marking of parts and product. These systems are capable of producing all kinds of codes, QR codes, DMC/DataMatrix codes, barcodes, alphanumeric characters, logos and letters that are produced reliably and with high levels of accuracy. The Y-Series includes nine different fibre laser sources, spanning power and pulse width ranges on one modular platform.

Where space is at a premium, the new TitusTM range, which offers 20W and 30W fibre laser markers, are not only incredibly small, but offer incredibly simple integration, opening up new areas of application for fast direct part marking on metals and other materials. The Titus Vector Scan laser marking head is just over 20 cms in length and weighs in at just 630 grams.

With its small format and tubular shape, the marking head is easily mounted with a simple clamping bracket and is available with an optional supply line of up to ten meters in length. Its flexibility is further enhanced through the option of either a



straight or 90 degrees exit angle for the laser beam, together with the ability to adjust the marking field size to the specific application requirements.

For applications which are predominately 2D and on flat steel components, the Universal Laser flat-bed systems offer a production level, yet competitively priced solution. Also available with range of laser power levels and sources, fibre and CO₂, these systems are equally at home within a production environment, prototyping or research and development lab.

Universal Laser Systems' patented Rapid Reconfiguration™ technology allows users to switch laser sources to match their changing requirements, without the need for tools or any specialist training. Depending upon platform model, there are



options on laser wavelength, CO₂ 10.6 µm, CO₂ 9.3 µm, or fibre 1.06 µm, in addition to a choice of laser power from 10W to 500W when combining dual 250W laser sources. There is also the capability in certain platforms for dual or multiple laser sources. At its core, Rapid Reconfiguration allows users to very easily install and reinstall any ULS laser source onto any ULS laser system. Because certain wavelengths and peak power levels are ideal for certain materials and applications, this feature allows for unprecedented flexibility in laser processing. With the diversity of industry sectors, applications and metals being used

today, it is essential that potential users of laser technology are able to consider all options available to them. We believe that we can offer a tailored solution to just about any metal marking application from our comprehensive range of technologies.

The different laser marking technologies described within this article are available from Bromsgrove-based TLM Laser and form just part of the comprehensive range of laser-based technologies and systems offered by the company.

TLM Laser
Tel: 01527 959 099
Email: sales@tlm-laser.com
www.tlm-laser.com



Dot Peen | Laser | Scribe | Chemi-Etch | Hand Tools

UK manufactured and supported portable, bench top and fully integrated marking equipment:

- » Batch codes
- » Serial numbers
- » 2D Data Matrix
- » Label marking
- » Direct part marking
- » Automotive marking
- » Aerospace marking standards
- » Full component lifecycle traceability

PRYOR

UK designed & manufactured since 1849



Contact Pryor to discuss your marking requirements:



+44 (0)114 276 6044

info@pryormarking.com

Laserax's new LXQ laser marker

After two years of development, Laserax has released the LXQ fibre laser marker series that redefines how easy and accessible laser system integration can be. The laser's features are not only aimed at reducing integration time and cost, but also at facilitating collaboration between system integrators and laser experts, a key factor for quick and easy laser integration.

To break the barriers of laser expertise, the system has a remote connection capability that can grant control of the system to a Laserax expert or partner anywhere in the world. Relying on a secure cloud VPN, this allows laser experts to better support integrators and end-users through remote services such as installation, training, after-sales support and live demos.

"In the aftermath of COVID-19, our capacity to provide support regardless of physical barriers will be ever more important," says Laserax president Xavier Godmaire. "We will be able to do this through remote support and with a local presence ensured by system integrators and partners. The LXQ Series will foster close partnerships between Laserax and integrators. It will make their lives easier by bringing our laser expertise to them, regardless of where they are."

Several features were developed to make system integration straightforward. A web-based HMI can be displayed in any web browser for a quick control of the laser without programming. The system's interfacing can be done using the most standard industrial protocols and fully configured peripherals are ready to be used. Among them, a Cognex camera for barcode

validation, an air-knife for lens protection and 3D-Autofocus sensors for automatic adjustments.

Apart from laser marking, LXQ fibre lasers can treat any metal surface with laser cleaning, laser texturing, and laser hardening. This is a game changer for system integrators who no longer need to go to one supplier for laser marking and another one for laser cleaning. They can integrate the same laser regardless of the application.

Founded in 2010 by two laser physicists, Laserax provides manufacturing industries with cutting edge laser technology. Its laser solutions include OEM systems and engineered solutions for marking, cleaning, texturing, and hardening applications. With local partners all over the world, its global presence is rapidly growing.

Today, an increasing number of the largest smelters and automotive manufacturers in the world rely on Laserax for their laser applications.

The company understands the demands of industrial processes and therefore it can engineer solutions that perfectly address each customer's specific needs. From the initial enquiry to the commissioning and after sales support, it is committed to being available to assist at any moment.

It first developed inline laser solutions for major smelting plants. In such environments, the heavy dust, high temperatures and short cycle times required robust marking solutions were non-existent on the market. Up to the challenge, Laserax worked in close partnership with smelters to develop standardised laser marking solutions aligned

with their needs. As of today, its conveyor machines are the only turnkey solutions available for smelters.

Hearing about its success in the primary metal industry, casting plants and automotive parts suppliers started showing interest in its expertise to help them meet their rising traceability needs. As automotive traceability requirements continued to evolve through new international standards, IATF 16949, marking parts after machining or quality control was no longer compliant with those requirements in many cases.

They needed a new direct part marking solution that allowed to increase the amount of information embedded in the part while keeping the cradle-to-grave traceability. In this case, this meant creating markings that sustain production and post-treatment processes, which is a challenge that Laserax managed to overcome.

Engineering solutions directly in casting plants and assembly lines also proved challenging due to high heat, strong vibrations, lubricant and dust. These obstacles created maintenance issues directly in the production line. Yet, Laserax succeeded in developing a standard product line that can operate with low maintenance in those harsh conditions.

Laserax
Tel: 001 418780 7324
Email: sales@laserax.com
www.laserax.com



Two marking systems for the price of one

The 2-in-1 Multi4 Combo dot peen marking machine combines both a benchtop and handheld marking system. It is ideal for subcontractors as the bench configuration can be used for small to medium sized components and changed to handheld in under 10 seconds for marking very large parts in situ, be it in or outdoors. The device has been designed to be the best of breed, both as a handheld and a bench system, with no compromise for usability, robustness or functionality and, being electromagnetic, it is quiet to operate.

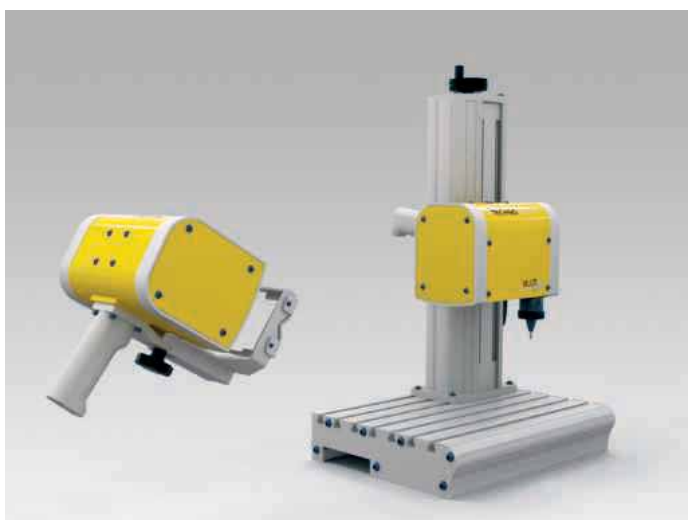

Get two systems for the price of one as the Multi4 Combo is currently available at the same price as a standard bench system. With a 3rd axis card fitted as standard, a rotary drive can be added at any time for marking around the diameter of a cylindrical item. The nameplate holder also makes it quick and easy to position and mark nameplates. Two marking head sizes allow 120 x 60 mm marking area or 50 mm x 60 mm.

The large HD colour screen has icon driven navigation, where all features are easily accessed, even if you lack strong PC skills, which means you can be up and running in as little as 10 minutes. A quick release height adjustment on the column also makes it fast to adjust the column height to suit the part being marked.

Users are able to mark alphanumeric data, 2D barcodes, symbols, logos, sequential numbering, part numbers, date/timestamp and

batch codes, while the patented IDI feature also allows marking over an uneven surface. Data can be input manually or imported from an Excel file, using foc PC software, often used for variable field filling.

If you need full portability around the factory, or for marking outside, the compact Combo can be supplied with an internal rechargeable battery. It will give you hours of use and automatically recharges when connected to the mains.

The Multi4 Combo utilises a linear X- and Y-axis as standard. This maintains quality of mark at the extremity of the marking path. The marking head is manufactured from a cast aluminium frame and metal casing which gives rigidity and high strength.

Universal Marking Systems offer a free sample marking service & online demonstrations carried out by its engineers who have experience across all industry sectors.

To find out more about the Multi4 Combo and the full range of Technomark dot peen and laser systems from Universal Marking Systems, contact:

Universal Marking Systems
Tel: 01420 565800
Email: info@ums.co.uk
www.ums.co.uk

+44(0)1527 959 099



INTRODUCING FOBA Titus™ THE WORLDS SMALLEST AND LIGHTEST FIBER LASER HEAD

Available as part of the new 20 Watt or 30 Watt FOBA Y.0200-xs / Y.0300-xs fiber laser marking systems:

- 20 centimetres in length
- 630 grams in weight
- Options on laser output
- Pilot laser included
- Focus finder



Agents & Distributors For:



Indoor mobile mapping solution

The Focus Swift is the first fully integrated indoor mobile mapping solution and is designed to accomplish large-area as-built capturing tasks with minimal time and effort. It is an innovative product that delivers better data faster and provides the most accurate measurements wherever needed.

As its name suggests, Swift is fast. Depending on accuracy requirements, the innovative device is capable of taking mobile scans of large complex areas up to 10 times faster than traditional static scans. Users can also directly import in any CAD system with 3D point cloud capabilities while simplifying their modeling with automated processes and optimising their scan to BIM workflow. Lightweight and portable, Swift is ideal for indoor scans of factories, office buildings, hospitals, and retail shops. Its intuitive, easy-to-use functionality combines the best of a FARO Focus Laser Scanner with FARO's ScanPlan 2D mapper and revolutionary SCENE mobile laser scanning software.

The device's simple push operation and comfortable handles, along with continuous cable-free operation without external power, means that operators can work faster and smarter while delivering better quality scans and enjoy a significant reduction in on-scene and processing time.

Compact for transport and crafted to fit in only two carry-on sized cases, the carbon fibre tripod and three-wheeled vehicle that accompany Swift can be easily folded for travel. It is features like this that make the 39lb device a high-value cutting-edge product, destined to increase productivity and reduce inefficiency. Additionally, its user interface is compatible to run on any mobile phone, so operators have real-time awareness of how much of a job has been completed.

It is lightweight and mobile, weighing 17.5 kg, meaning it is easy to walk with in indoor locations and with less bulk. It is also ideal for fast walk-throughs or detailed scans and has multiple-software compatibility. The Focus Swift is compatible with FARO As-Built™, BuildIT Construction and WebShare Cloud and directly imports in any CAD system with 3D point cloud capabilities. Modeling workflow is simplified with automated processes and it optimises scan to BIM workflow.

As-built capturing jobs that would require,



for example, one hour or more with stationary 3D laser scans could be accomplished in about six minutes with Swift. 3D accuracy from 2 mm to 10 mm is provided with scans up to one million points per second via mobile and two million via stationary.

Featuring an intuitive design, the Focus Swift from FARO has comfortable handles with simple push operation. Its lightweight design provides easy mobility and setup wherever needed and its versatility is ideal for factories, office buildings, hospitals and more.

Innovative automation eliminates manual processing steps and combines several leading technologies, including FARO's patented Focus Laser Scanner. Designed for a wide range of thermal conditions, operating from 5°C to 40°C, it can be stored in temperatures up to 60°C, although 25°C is recommended.

Enhanced battery operation provides two hours on a 14.4V internal battery. The operation time can be extended using additional battery packs with continuous cable-free operation without external power.

The FARO Focus Swift maximises productivity, cuts on-scene time and enhances the overall scanning experience with its lightweight, intuitive design. Swift will also help large construction companies, general contractors and facility and plant

managers as they scan the interiors of their respective buildings.

The ingenuity behind Swift lies in its design and software compatibility as operators can work with FARO As-Built™, BuildIT Construction and WebShare Cloud. Users can also directly import in any CAD system with 3D point cloud capabilities while simplifying their modeling with automated processes and optimising their scan to BIM workflow. Internally, Swift is powered by the revolutionary FARO SCENE software, which automatically processes data from Focus and ScanPlan into accurate 3D point clouds.

FARO SCENE processes and manages scanned data efficiently and easily by using automatic object recognition and scan registration and positioning. SCENE can also colorise scans. This point-cloud software for scanners is extremely user-friendly and generates high-quality data in no time. Now, scanned data can be easily shared worldwide with project partners using FARO's cloud-based hosting solution SCENE WebShare Cloud.

FARO Technologies UK Ltd

Tel: 02476 217690

Email: uk@faro-europe.com

www.faro.com

FANUC launches new 3D vision sensor with extended field of vision

FANUC has expanded its range of integrated image processing solutions with the introduction of the 3DV/600 Vision Sensor.

The new sensor benefits from an extended field of vision in comparison to other models in the range and is designed for use in multiple applications, including bin picking, feeding an assembly line, or stacking pallets. Complete with the 2D Camera Package, 3D Laser Sensor and 3D Area Sensor, the 3DV/600 forms part of a highly-integrated, high-performance portfolio for industrial image processing.

Andy Armstrong, sales and marketing manager, comments: "The 3DV/600 is a practical and user-friendly addition to the range, capable of being fitted permanently into a system, or temporarily on the last axis of a robot. The other models in the 3DV series have proved hugely popular and, by expanding its field of vision, we've ensured the 3DV/600 can deliver the high levels of performance demanded by ambitious manufacturers."

Its high level of integration and very short image processing ensures that the 3DV/600

can be combined with the iRPickTool for use on a conveyor belt, able to pick up items even if they are irregular-shaped or have no clearly defined pick-up point.

The 3DV/600 is pre-calibrated, which makes installation as straightforward as possible. After the sensor is installed, the robot simply has to identify the position of its 'eyes', and a setup-wizard supports and guides you through the necessary settings. Furthermore, no interface development is needed, as the FANUC 3D Sensor support is fully integrated into the robot software.

Andy Armstrong continues: "By fully integrating the 3DV/600 Vision Sensor, a huge amount of time is saved at both the installation and image capturing stage. The 3D-Snap-in-Motion function allows the robot to trigger the snapping of an image while in motion, which saves a lot of time and is something a non-integrated vision system would be unable to do."

As with other sensors in the range, the 3DV/600 is equipped with blue LED lighting as standard and connected with a single



cable, which reduces clutter and makes maintenance much easier for the end-user.

Andy Armstrong concludes: "The 3DV/600 has been designed with the user in mind, designed to ensure it is as intuitive as possible. It's integration and expanded field of vision make it an ideal addition to a range of FANUC robots."

FANUC UK Ltd
Tel: 0121 456 3004
Email: sales@fanuc.co.uk
www. www.fanuc.eu/uk/en

World's first portable coordinate measuring machine from Trimos now available in the UK

Sole distributor for Trimos products in the UK, Bowers Group has introduced the world's first truly portable Coordinate Measuring Machine (CMM) the Trimos C-Line. Both the C3 & C4 models weigh just 13.5 kg, are battery operated and available with Bluetooth, allowing full portability.

The C3 model is perfect for manual measurements, while the C4 is fully CNC operated. A simple and intuitive icon-based

touch screen mounted on the machine provides ease-of-use, and optional Aberlink software is available to assist with CAD programming and traditional CMM style reporting.

UK sales director for Bowers Group, Martin Hawkins, says: "We are delighted to introduce new Trimos C-Line CMM to the UK market. After the success of the recently introduced Trimos Portable Arm, the C-Line makes a great addition to new Trimos 3D product group. Being fully portable, you can take the C-Line CMM right to parts in the manufacturing process for inspection; it's a really useful bit of kit."

With a working volume of 700 mm, X & Y and 250 mm, Z, its small footprint and high-performance 3D measurement is the ideal portable solution for any workshop operation. Delivered as standard with the ControlCAT software, the C-Line allows operators to perform a variety of measurements including; distance, circle, plane, line, and point.

Trimos has been a leader in the field of

dimensional metrology since 1972, guaranteeing 'Swiss-made' quality from its manufacturing. Trimos offers a range of solutions that respond to dimensional measurement needs, combining high precision, innovation, advanced design and ease-of-use. As sole UK agent, Bowers can exclusively offer its customers the full range of Trimos height gauges, horizontal measuring instruments and surface analysis instruments, along with the new 3D product group which includes portable measuring arms and portable CMMs.

To find out more, speak to a member of the team, or to receive a demonstration, please contact us by calling 08708 50 90 50, or emailing sales@bowersgroup.co.uk.

Bowers Group
Tel: 01276 469866
www.bowersgroup.co.uk



Ultra-cut 130 XT high-precision plasma power source

30 percent more power, 20 percent faster cutting

Thermal Dynamics Automation has introduced the Ultra-Cut® 130 XT high-precision plasma power source with an improved 130-amp XT torch and new consumables. The system has a cutting output of 130 amps at 100 percent duty cycle and is optimised for piercing and cutting 20 mm steel, stainless and aluminum. Compared to the previous Ultra-Cut 100 XT, it offers 30 percent more power, 20 percent faster cutting speed and 50 percent longer parts life at 130A on mild steel. The Ultra-Cut 130 XT cuts 20 mm at 1,321 mm/min and 12 mm at 2,159 mm/min. It has a maximum cut capacity of 40 mm, edge start.

"The Ultra-Cut XT 130 offers industry's best combination of cut quality, cut speed and lowest cost of operation," says Dirk Ott, VP for global mechanised plasma systems at Thermal Dynamics Automation. "The Ultra-Cut 130 XT covers the 20 mm market, which is a large portion of all applications, at a very aggressive price point." He notes that the Ultra-Cut 130 XT offers a good retrofit opportunity for those with older 100- or 130-ampere systems.

Improved torch

The new 130-amp XT torch features Thermal Dynamics' patented SpeedLok consumables cartridge, which allows users to change consumables in seconds. An improved torch head alignment in the torch reduces variations between cut sides for better tolerances. To increase flexibility when mounting the torch in a plasma bevel head, Thermal Dynamics now also offers a 76 mm shorter torch mounting tube.

The new 130 A consumables design also reduces oxygen, plasma gas, consumption by 40 percent compared to other systems, further lowering cost of operation.

In addition to Oxygen, plasma gas options include Nitrogen, Air, H35 and argon for marking; shielding gas options include oxygen, air, nitrogen and water. All XT torches use existing parts for underwater cutting when fabricators want to reduce smoke and glare.

The Ultra-Cut 130 XT, coupled with an improved version of Thermal Dynamics Diameter PRO software, found in the iCNC Performance Controller, offers better cut perpendicular, sharpness and consistency, allowing for outstanding hole quality. Bolts

fit even better and holes require little or no rework. OptiHole database is also available for integration with any third-party CNC control.

Ultra-Cut family features

The Ultra-Cut 130 XT offers all the familiar features of the Ultra-Cut power sources, including StepUP™ modular power technology that allows 130-, 200- and 300-amp systems to be upgraded to a maximum output power of 400 amps. "The ability to add inverter blocks means fabricators never have to worry about purchasing a system that does not have enough capacity to meet future needs," says Dirk Ott. "Fabricators can easily and economically upgrade to a more powerful system when they require greater cutting capacity."

The Ultra-Cut 130 XT also cuts aluminum and stainless steel using Thermal Dynamics' Water Mist Secondary (WMS) process, which incorporates nitrogen as the plasma gas and tap water to generate the shielding gas. On stainless steel, the WMS process cuts up to 300 percent faster and lowers cost-per-cut by 20 percent or more compared to systems that use H35 for the plasma gas. The WMS high-precision plasma process makes ISO Class 3 cuts or better on stainless steel and aluminum up to 20 mm thick.

Like all Ultra-Cut XT units, the Ultra-Cut 130 XT comes with a ScrapCutter option that gives owners the ability to connect a manual 1Torch™ directly to the front of the unit for plasma cutting of plate skeletons to simplify scrap removal. The ScrapCutter option provides a constant 100-amp output, and torch lengths of up to 30 metres are possible.

Thermal Dynamics brings intelligence to the automated plasma table with a suite of fully integrated components that enable users to orchestrate the fastest cut, best cut and lowest cost per cut regardless of operator experience.

ESAB Group (UK) Ltd
Tel: 01992 768515
Email: service@esab.co.uk
www.esab.co.uk



Partnership to push technology in steel construction

HGG Profiling Equipment, specialists in highly accurate high-speed plasma cutting and 3D profiling, and KALTENBACH, one of the leading worldwide manufacturers of equipment for steel fabricators and steel service centres, have announced a strategic cooperation for the steel construction market in a wide geographical area. The partnership between KALTENBACH and HGG is focused on thermal cutting, coping, drilling and sawing solutions for profiles and beams.

“In order to push the boundaries of technology and stay ahead of the game, technology suppliers need to achieve a high degree of specialisation. By combining the best of thermal cutting with the best of sawing/drilling we create a total solution which offers a significantly higher value for our clients and stands out from the competition,” states Daan van Dee, HGG global channel manager.

KALTENBACH will add a new coping robot to its product range which is powered by HGG. The new coping robot is the worlds most advanced thermal cutting robot, combining HGG’s powerful software, state



of the art scanning methods and cutting intelligence with German engineering and manufacturing quality as well as years of experience in the steel business.

“At KALTENBACH we strive to supply our customers with the very best solution for each type of technology. In the field of 3D coping HGG has been known for years as the technology leader and by integrating this technology in our automated steel processing systems, we increase our customers’ productivity significantly,” says Matthias Rummel, managing director of sales at KALTENBACH CSO.

Right from the start, the partnership turned out to be a perfect fit and it has been positively received by the market. By combining the development forces of both



parties, the possibilities for customers are endless.

HGG Profiling Equipment BV, founded in 1984, are specialists in highly accurate high-speed plasma cutting and 3D profiling, providing ready-to-fit welded connections without the need for layouts. The company calls it FitPerfect™ Technology. One part of the company focuses on the development and manufacture of 3D profiling machinery, while the other part performs 3D profiling cutting services with that same machinery.

KALTENBACH Ltd
Tel: 01234 213201
Email: sales@kaltenbach.co.uk
www.kaltenbach.co.uk

The BEHRINGER GROUP Stronger than ever together



STRONG and EFFICIENT

Behringer Ltd, part of the Behringer Group of companies, offer a broad range of machines from straight cutting, mitre cutting to circular sawing machines and a comprehensive range of the Vernet Behringer structural steel processing machines.

STRONG and built with solid cast iron parts and highly **EFFICIENT** due to high cutting performance and low maintenance costs.

We are happy to support you with Service, Spare Parts and Machine requirements.



HBE 261A-1060A



HBE 320-523GA



VMS 300



PSU 450 H



LPS60T



HBM540A



HCS 160 Multifluid



VA-L 560 NC2

Efficient sawing in the cutting range up to 1,060 mm

The new HBE1060A Performance

Since its foundation in 1919 in Kirchartd, Germany, Behringer has proven to be a real innovation specialist. As one of just a few complete providers in the sawing technology market, the company offers both bandsaw and circular saw machines as well as machine tools for the steel construction industry.

With the HBE Performance series, which sits alongside the HBE Dynamic series, Behringer is offering a particularly robust and powerful product line which can especially hold its own in harsh environments. Behringer is now extending this series with the largest model, the HBE1060A Performance.

With a cutting range of 1,060 mm in round stock and 1,060 x 1,060 mm for square material, the HBE1060A Performance can be used for a wide range of applications, such as those found in the steel distribution, machine building and toolmaking or in steel finishing.

The HBE series: clever and flexible

Bar steel or solid materials made of non-ferrous metals or plastics, slabs, large pipes or profiles, the HBE1060A Performance covers a wide range of

applications. Just like the smaller models in the series (HBE663A and HBE860A), it offers impressive features which significantly improve process reliability during sawing.

The HBE series is controlled via the user-friendly and easy-to-use BT65 touch control which provides maximum support to the user as they work. Once the material to be sawn has been selected from the extensive database, the auto feed control, which comes as standard, provides all the necessary technological values for the cutting speed and the servo-controlled feed. Together with the cutting pressure control, which detects the cutting force on the back of the bandsaw blade, the cutting parameters are continuously adjusted in line with the current status of the bandsaw blade, thereby providing effective protection against overload.

When it comes to sawing large diameters at slow feed speeds, the HBE1060A Performance servo feed system really excels compared to hydraulic systems. The steady feed movement provided by the ball screw spindle and servo motor provides constant chip removal and helps ensure a quiet and stable cutting process. This results in a machine with high cutting capacity and blade service life.

Impressive efficiency and low noise

Behringer uses self-produced vibration-dampening cast parts where it makes structural sense to do so. The sawing unit, supported by a torsion-resistant gantry structure, features bilateral double-wheel support. So, not only does the HBE1060A Performance impress with its extremely quiet running, precise cuts and gentle operation, in regard to the bandsaw blade, it also delivers maximum quality. The inclined position of the band wheels also helps protect the bandsaw blades as a result of reduced flexural stress. Thanks to its automatic guide arm, the bandsaw blade is always guided close to the cutting point, which is extremely convenient when it comes to handling frequently changing material cross sections.

No-compromise energy efficiency

Rising energy prices mean that companies are rethinking their existing processes and drawing on technological innovations to develop new solutions for achieving greater output with less energy input. "With the new HBE Performance series, we are demonstrating that energy efficiency and powerful hydraulics are not mutually exclusive," explains Christian Behringer.



“In doing so, and with modern, application-appropriate drives, we have been able to reduce the energy required by the machine by over 30 percent in comparison to the predecessor model.”

Reliable, proven technology

With the HBE1060A Performance, Behringer has opted for a wide chip conveyor with integrated coolant tank which is located under the funnel-shaped machine stand. Chips and coolant are thus reliably fed to the conveyor and the conveyor can be easily moved out of the machine for cleaning purposes. The ejection height of 800 mm means that large chip containers can be used.

Even the bandsaw cleaning of the HBE1060A Performance has been taken to the next level. An electrically powered brush effectively cleans away any chips that have adhered to the bandsaw blade. The quick-change device allows users to quickly change worn brushes without the need for any tools.

Functionality and design

The new full enclosure for the machine not only fulfils current CE directives, it also



meets the growing demand for user-friendliness, occupational health and safety, and environmental protection. The benefits are self-evident: a clean working environment and noise reduction combined with an optimal view into the machine. The maintenance-friendly concept enables easy bandsaw blade changeover without tools and excellent accessibility for maintenance or cleaning work.

For more information relating to Behringer and Behringer EiseleNew, other products and after sales support, contact:

Behringer Ltd
Tel: 01296 668259
Email: simon.smith@behringerltd.co.uk
www.behringerltd.co.uk

Cutting Blades

From the smallest to the largest, Accurate can cut it. With our 25 tonne lifting capacity, 2000mm diameter or 6000mm x 1000mm in a single pass cutting capacity we have the largest subcontract cutting capability in the UK.



Plate and block cutting, tube and solid bar, structurals, castings and forgings all sawn to size on heavy duty bandsaw machines. Any alloy or condition, shape or size. **If you would like to know more, give us a call.**



Amada bimetal, carbide and powdered tip bandsaw blades made to size for delivery anywhere in the UK.

Precision ground blade tips using latest tip materials give a lasting blade life and good finish.

We also supply Julia circular saw blades in HSS, coated or tipped form ground to your requirements.

Call to discuss your requirements.



Saws



Quality saws from Amada and Soitaab band and circular saws.

Manual, mitre, plate and gantry saws and fully automatic sawing systems capable of cutting up to 3000mm diameter, Accurate can supply a saw to suit your requirement.

Call our sales team to discuss



44-45 Crossgate Road
 Park Farm Industrial Estate
 Redditch
 Worcestershire
 B98 7SN

T: 01527 527058
E: sales@accurate-cutting.co.uk
W: www.accurate-cutting.co.uk

Bruderer helps boost production output by 400 percent

A leading supplier to the European car market has invested in its first ever Bruderer to help it increase output for current and future models.

Xandor Automotive Canning Brett, which manufactures exterior, interior and under bonnet components, installed a refurbished BSTA 40 high-speed press and BBV 202-120 feeder three months ago and is already achieving a 400 percent daily increase in volumes on selected lines.

The company is using industry-leading control and patented ram tool guidance technology to manufacture up to 200,000 clips, fasteners and washers every day, with the flexibility of the bed size and 1,200 strokes per minute capability future-proofing its investment for years to come.

"The car industry is all about achieving more efficiencies and this means constantly looking at getting the most out of your manufacturing processes," explains Gethin Williams, production shift manager at Xandor Automotive Canning Brett's specialist metal pressings site in Swansea.

"We had identified a number of parts that could be made quicker and in higher daily volumes, whilst still retaining the same level of repeatable quality. This prompted us to look for a new press and this is where Bruderer UK came into the equation, visiting us and identifying a solution that would work.

"They arranged for us to take a tool up to their site in Luton and run it on the actual machine we were interested in and the results were very impressive."

Bruderer's BSTA 40 tonne press can operate up to 1,200 strokes per minute and offers a bed area of 690 mm x 550 mm, ideal for allowing slightly larger tools to be used that do not require the extra tonnage.

The press has also been designed to provide a range of adjustable strokes, from 13 to 57 mm, with the longer stroke suitable for small electrical components and a shorter stroke for more intricate formed parts.

Xandor Automotive Canning Brett, which was keen to optimise performance and reliability, also invested in a tonnage and tool protection package that has improved the tool life significantly.



Gethin Williams adds: "The first few months have been impressive, with the BSTA easily the best performing machine we have at our Swansea facility, which employs 46 people.

"These production uplifts have given us the confidence to actively go out and tender for new projects in new markets. I'm pretty certain it will not be the last high-speed press we buy from Bruderer, especially if it continues to quadruple daily output on certain parts."

Managing director Adrian Haller at Bruderer UK continues: "This is the first machine we've ever supplied Xandor Automotive Canning Brett and we're delighted it has had an immediate impact on its productivity and ability to cope with increased volumes.

"It all started with our desire to spend time with a potential client, look at its entire manufacturing operations and where we feel that our technology can add real value. The answer on this occasion was a refurbished BSTA 40, which offers world class speed, accuracy and control.

"Once we'd shown Gethin and his team the performance first-hand, it was an easy decision for them to make and the installation, commissioning and training was all completed within a two-week period.

"Our technology has delivered higher



quality parts with far less burr, faster tool changes to support the implementation of Single-Minute Exchange of Dies (SMED) and freed up capacity as it is doing the work of three conventional presses."

Bruderer is renowned the world over as a pacesetter in high-quality punching technology. The company, which was founded in 1943 by Egon Bruderer, took just a few years to develop from humble beginnings into a global player. This huge success can be attributed to its high-quality products, an extremely high level of quality production and being a customer-oriented sales and service organisation.

Bruderer UK Ltd
Tel: 01582 560300
Email: mail.uk@bruderer.com
www.bruderer.co.uk

New storage system interface automates sheet metalworking

Automated material flow offers manufacturers significant time and cost savings. With this in mind, KASTO has introduced a new system for efficiently transferring material automatically between its sheetmetal storage towers and flat-bed processing plant, such as laser cutting machines and turret punch presses. It enables minimally attended production, achieves high throughput speeds and relieves staff of the laborious and potentially risky task of handling large metal sheets.

The system comprises two sheet manipulators suspended from a gantry projecting from the storage tower and two pick-and-place tables below. These are positioned side by side the same distance apart as the manipulators, the table nearer the tower being a similar distance from it and fixed to the floor. The second, shuttle table has a slatted surface and is rail-mounted, allowing it to travel to a production area and back.

The manipulators operate differently in that the one closer to the tower uses an array of suction cups to hold the sheet

during lifting and lowering, whereas the other employs a rake-type gripper that opens so that the rake tips move further apart than the width of the sheet, allowing it to be lifted from underneath off the slatted shuttle table after the rakes have closed.

The manipulators always move horizontally in unison and vertically in opposite directions. They are not identical, as the vacuum type only handles fresh, flat sheets from the tower to the fixed table, while the rake type, in addition to passing that sheet to the shuttle table, is also required to lift and deposit processed material from the shuttle table to the fixed table. The latter, more secure method of handling is needed as the sheet may contain loose components that have to be supported. In any case, the material may have been distorted during machining, making suction cup adherence unreliable.

A similar rake-type manipulator is also present at the machine tool end of the rails, either to handle fresh and processed sheet automatically or to assist in their manual transfer between the moveable KASTO

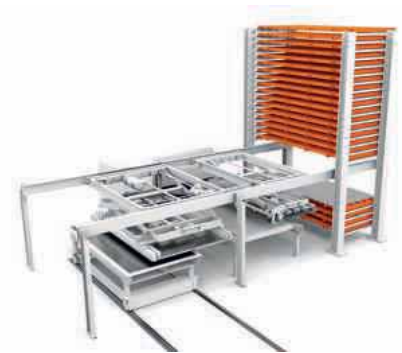

table and the shuttle table serving the laser or punch press.

The system is not designed to return the sheet containing laser-cut or punched components back into the storage tower, although such fully-automatic operation can be supplied by KASTO with double pick-and-place stations and with manipulators moving independently, one above the other.

KASTO Ltd
Tel: 01908 571590
Email: sales@uk.kasto.com
www.kasto.com



For solid, reliable
 down to earth advice,
 contact Kerf today.

Oxy-fuel, Plasma, UltraSharp and Waterjet Cutting Technology

Machine sales, service, support and consumables



Call us on: +44 (0)1706 757 670

www.kerfdevelopments.com | Email: sales@kerfdevelopments.com

Kerf Developments Ltd, Unit 1a Eagle Technology Park, Queensway, Rochdale, OL11 1TQ

West Wales company is a trailblazer with new Kerf machine

Founded over 30 years ago in a small 'shed', CLH Trailers has grown into one of the UK's leading manufacturers of trailers for the agricultural, fishing, marine, sport, leisure and farming industries. As the product range has grown, so has the factory, staff levels and investment in technology with the latest addition to the plant list being a plasma cutting machine from Rochdale manufacturer Kerf Developments.

Located in the picturesque village of St Clears, between Carmarthen and West Wales holiday hotspot Tenby, the 15 employee business manufactures hundreds of trailers every year and, with anything from 50 to 200+ components in each trailer, productivity and precision are critical for CLH Trailers. With a burning desire to keep moving the business forward, managing director Chris Hussell and shop floor foreman of over 20 years, Mark Reynolds started looking at available options for cost savings and productivity enhancements.

Taking up the story, Mark Reynolds says: "First and foremost, we wanted to buy British. We looked for a viable option and we realised that laser cutting wasn't suited to our business whereas plasma was a perfect fit. We found several vendors and we then spoke with customers for their testimonials. Out of the UK manufacturers, it was Kerf that had a reputation above all others. This reputation was backed by their



customer approach and, of course, the quality and productivity of their demonstrations. We were about to purchase a RUR 2500p plasma machine with a 4 m by 2 m bed and then the pandemic hit. We initially put the order on hold, but as the lockdown continued and we retained a steady level of business, we realised that the potential benefits of the Kerf plasma would send our business on a forward trajectory, so we finalised the order during the pandemic and the machine was delivered in July."

Primarily cutting black steel and aluminium in thicknesses from 1.5 mm to 25 mm, CLH Trailers specified the

RUR2500p machine with the user friendly Burny 10 LCD CNC controller, the powerful 275 amp Lincoln Spirit II 275 plasma unit and Lantek software to drive the high-definition Ultrasharp cutting technology. Building a new factory unit specifically for the new Kerf machine, managing director, Chris Hussell says: "I wanted a machine with a robust build quality that is capable of running all day, every day. The Kerf machine certainly gives us that. The plasma unit can cut steel beyond 60 mm thick, which is more than we need and the precision, repeatability and edge finishes are exceptional. We predict that the machine will pay for itself in less than two years."

Creating savings everywhere

Looking closer at how the new Kerf plasma will create such significant savings, Mark Reynolds continues: "As a business, we typically have six staff manufacturing parts to complete an average throughput of two trailers each day. The majority of parts require guillotining, notching, drilling, grinding, corner rounding, bending and welding before galvanising. Each of these processes can be slow and labour intensive and with each subsequent operation, there is an increased opportunity for error and potential scrappage. With the Kerf machine, we can do many of these operations in a single setup. Going forward, this will free up at least two employees for other tasks. A labour saving of at least £40k is great; but



equally important for a company in a rural area is that the plasma allows us to grow the business while re-distributing the highly skilled staff we have."

Providing a practical example of savings, the mudguards on each trailer are processed in quantities of six to eight from an 8 ft by 4 ft sheet of 1.5 mm thick black steel.

Mark Reynolds says: "The batch of mudguards would take 10 minutes to cut on a guillotine, then another 10 minutes on our variable angle notching machine followed by another 10 minutes for marking and subsequent drilling with the final process before bending being the grinding and rounding of the corners, which takes another five minutes. If you add to this total of 35 minutes additional time to move the mudguards from machine to machine and position the parts in jigs, you're looking at over 40 minutes. The Kerf plasma will profile and cut the holes in less than 10 minutes with far superior precision. Not only does the Kerf machine reduce our cycle times by more than 75 percent, but it also removes the opportunity for operator error, improves quality and consistency, eliminates hand finishing and frees-up capacity from existing machines."

"We've only had the Kerf machine a matter of weeks and it has already lightened the workload of our staff and our machines, streamlining our production. Our guillotine was working for over four hours a day, now it's only used for an hour a day."

Design for life

Manufacturing ATV, livestock, flatbed, beavertail, container, motorbike, boat, tipper, tilt-bed, signage, car transporter and camping trailers to name a few, each design can have beyond 200 components. At present, the Kerf high-definition plasma is only cutting 15-20 different components, something that will rapidly change, as Mark Reynolds states: "Our designs and aesthetics were limited by our machine capabilities and also a limited appetite for innovative designs from the 'function-first' approach of the agricultural sector. The Kerf machine opens up a world of opportunity to redesign trailers for improved aesthetics, functionality, lighter weight and even the potential for reduced components and shorter assembly times. The mudguards are one component that we have already redesigned to improve the aesthetics, reduce material usage and weight and also offer a wider range of shapes and sizes. This is the first demonstration of how we can move our designs forward to create a greater appeal among the consumer market."

Another example of design for manufacture and aesthetics is the winch post for boat trailers. Previously manufactured from three pieces of 5 mm thick steel that are each cut to size, punched, notched and then jugged for welding; each winch post takes



30 minutes to produce, a time only achieved when efficiently processing in batches of 20+.

"The capabilities of the Kerf machine have allowed us to redesign the winch posts and these are now profiled with holes in less than two minutes with an additional minute for second-op bending," continues Mark Reynolds. "Essentially, the Kerf machine is giving me more time to be productive elsewhere and even look at other opportunities for the business."

Looking to the future, Chris Hussell concludes: "We have always undertaken an element of subcontract metalworking and fabrication, but now we can extend this significantly. The Kerf machine has only been here a short while and we are already doing decorative wrought iron fencing, cutting letters and signage and much more. The potential of the Kerf machine is huge. Equally significant are the savings. On top of the labour and cycle time savings, the reduced waste and added capacity throughout our facility has been hugely noticeable in a short period. But, one of the biggest savings for us will be on the material. We order 6 tonnes of sheet steel every month and an additional 4-5 tonnes of box section, up to 30 percent of this is wasted in off-cuts that are sent back for recycling."

"With the Kerf plasma we have already taken our material utilisation from 70 percent to 85 percent and the more familiar we become with the machine, the more material and costs we will save."

Kerf Developments Ltd Tel: 01706 757 670

Email: sales@kerfdevelopments.com www.kerfdevelopments.com

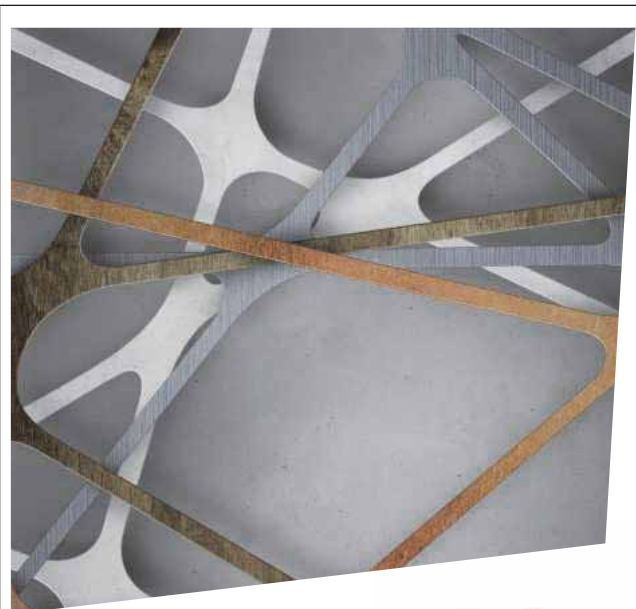

We think
one cut ahead.

Waterjet cutting system by StM.
stm.at

StM

Waterjet solutions

The cool revolution in tool maintenance

RUD's Tool Mover takes the strain out of tasks such as unmounting heavy tools from injection moulding machines or dismantling machine parts weighing several tonnes that previously needed a crane and at least two operators. This latest generation of the innovative Tool Mover provides users with a much larger working surface at the lowest possible working height. This isn't just "cool for tools" but has major benefits for operators, workshop managers, workplace safety inspectors and financial controllers. With Tool Mover, handling tools has never been so safe, efficient and effective in terms of costs or processing.

RUD's Tool Mover can be supplied in configurations that suit your exact requirements. For example, the smallest slim version can handle weights of up to 10 tonnes on its sturdy 800 mm table surface. The Tool Mover system has been designed for use in the tool and mould-making industries, with injection moulding and pressing tools and with pressing, bending and forming technologies. It is also ideally suited for applications in the automotive, electronics and packaging industries.

"If you're looking for a win-win situation



for everyone involved in maintenance, you can't do better than Tool Mover. Financial controllers are pleased that the machine pays for itself in less than a year. Operational managers and workshop managers benefit from much shorter maintenance processes and service teams can work more efficiently without risk of injury, thanks to the machine's ergonomic design," explains Anne Kühling, product manager in the conveyor & drive division at RUD Ketten Rieger & GmbH und Co. KG, headquartered in Aalen, Germany.

When designing the latest generation of the Tool Mover system, RUD's engineers reduced the height of the working surface on the smallest model to 595 mm. "Enabling

users to work as ergonomically as possible was really important to us. This lower working height means that opened tools can be maintained directly on the working table. Operators can work more comfortably in a natural posture and there are fewer setup costs," says Klaus Pfaffeneder, head of design at RUD Ketten.

The Tool Mover has revolutionised maintenance procedures, enabling operators to work in full compliance with occupational health and safety regulations.

RUD's Tool Mover makes it really easy. This innovative tool-handling machine is designed to axially rotate tools and machine components weighing up to 64 tonnes. It rotates and turns over even the heaviest loads, reliably and safely. The machine turns over loads smoothly in their centre of gravity. The Tool Mover's

worktable has a frequency-regulated drive to ensure it stops and starts smoothly, without juddering. RUD's Tool Mover is also fitted with a high-end drive system from the TECDOS range. The Omega Drive at the core of the system ensures perfect rotation during turnover.

The Tool Mover can turn over objects at least twice as quickly as a crane, in less than a minute. Plugs or cooling hoses that usually have to be dismantled for safety reasons during component maintenance using a crane can simply stay in place when the Tool Mover is used to turn over the components.

In some cases, you might even save a great deal of money by installing a Tool Mover in your workshop instead of investing in an expensive crane system. The Tool Mover can be moved easily with a forklift truck or pallet truck, etc and installed exactly where it is needed. "This gives



companies entirely new options for planning production sites. Maintenance procedures and logistics can be completely rethought to benefit from the potential for new hall layouts and innovative handling processes," explains Anne Kühling.

The Tool Mover also protects existing infrastructure as the tools and machine components no longer have to be dragged over to maintenance points.

RUD manufactures the Tool Mover at its headquarters in Aalen, Germany. Available in six standard sizes, the Tool Mover is ideal for a wide range of tool sizes.

The Tool Mover's wireless control units have also been designed with practicality in mind: with them, operators can control the rotating table safely and conveniently from outside the danger zone.

RUD Ketten Rieger & Dietz GmbH und Co. KG
Tel: 0049 7361 5041457
Email: salesfa@rud.com
www.rud.com



The Revolution is here!

Spindle Revolution has opened a new state-of-the-art Spindle Repair Facility in the heart of Gloucestershire. Proudly supporting UK manufacturing, we have re-shored our business to ensure all UK customers receive unrivalled repair times coupled with our most competitive pricing.
Spindle Revolution. Excellence as Standard.

Minimise your machine downtime with our pool of exchange spindles

12 Month Warranty* supplied with all spindles
* Or equivalent 3000 working hours

All repairs are fully documented and traceable throughout the complete repair process

We have the capacity to test run all spindles and motors up to 180,000 r.p.m

Meticulous attention to detail ensures our reports give an honest appraisal of the condition of your spindle

All spindles are supplied super precision balanced, comprehensively tested and delivered ready for installation



Technically Advanced Spindle Repairs

We repair mechanical and electro-mechanical spindles for CNC Machining Centres, Lathes, Routers, Grinders and Boring Heads.

All makes supported inc: Diebold, DMG, Fischer, Franz Kessler, Gamfior, GMN, Makino, Okuma, Omlat, Step-Tec, Weiss and many more....

sales@spindle-revolution.uk

Call now for a free, no obligation quotation

www.cnc-spindle.repair 01594 368 484

The Next Generation

The latest additions to the Colchester Machine Tool Solutions range with the same exacting standards rigidity, reliability and performance.

Vertical machining centres taking the industry by **Storm**

The Storm VMC's are an impressive range of high performance, heavy duty vertical machining centres. Combining high speed big-plus spindle with precision roller linear guideways ensuring that the STORM series gives outstanding accuracy and performance.

Features

- Hand scraping during assembly process for high accuracy.
- Rigorous testing including laser interferometer and ball bar.
- Dual contact Big Plus Spindle as standard.



The ultimate turning machine, the **Alpha CNC**

The Alpha range, powerful and flexible CNC combination Lathe that can be utilized for large production runs or 1 off components.

Features

- Can be used manually.
- Has 4 operating modes:
- Alpha mode – simple to program, no CNC knowledge required.
- Manual Guide i – full conversational programming with 3D graphic display.
- ISO programming capabilities using standard M and G codes and canned cycles.
- Alphalink CAD/CAM supplied with machines for offline programming.
- Ideal for training apprentices, or new and old operators.

**LOW RATE
FINANCE AVAILABLE**

3 months payment free
and extended 3 year
warranty on parts
and labour*

*T&C's apply

