

# HELLER

Connect to the world  
of solutions



## Next Level Networking

Join us when it comes to thinking in completely different dimensions in November. Meet us and our partners at the **V-CON 2020**.

Discover our virtual world of machining solutions, use the opportunity to network and exchange ideas, benefit from concentrated expert knowledge, get live insights into real applications and much more.

A unique trade fair experience and combined competence from our network.

[#hellergroup5d](#)

Save the date:

**10-12 NOVEMBER 2020**

Stay informed: [heller.biz/en/company/newsletter](https://heller.biz/en/company/newsletter)

For questions: [v-con@heller.biz](mailto:v-con@heller.biz)



New Dimension  
**V-CON 2020**

**NEW**

# 510mm turning length

**XYZ CT 65 HD**

**SIEMENS  
Touchscreen**

**BOX WAY  
SLIDES ✓**

**SIEMENS 828D SHOPTURN  
TOUCHSCREEN CONTROL.**  
**SPINDLE MOTOR 23 HP /17 kW.**  
**200mm HYDRAULIC CHUCK.**  
**66mm BAR CAPACITY.**  
**4000 RPM.**

**VDI30 SAUTER GERMAN TURRET.**  
**RENISHAW TOOLSETTING.**  
**SWARF CONVEYOR BIN.**  
**HYDRAULIC TAILSTOCK.**  
**SOLID CASTING 3600 kg.**  
**SMALL FOOTPRINT.**



*The 12 Station Turret and the Automatic Tool Pre-Setting Arm gives the operator consistency when measuring tool offsets.*



With the now increased Z axis travel this 'box way' HD turning centre is for those who need to get the job done.

## XYZ Compact Turn 65 HD with box way slides

We have been selling the popular Compact Turn 52 and 65 for many years, with over 300 machines in the field, this BOX WAY machine has proven to be a great workhorse, but due to customer demand we have increased the maximum turned length from 260mm to 510mm. Each machine comes with a wide range of standard equipment normally offered as options on competitor machines, these include hydraulic chuck, 12 station VDI Sauter Turret, Renishaw tool setting, swarf conveyor and tailstock. The control is the latest Siemens Touch

Screen 828D with ShopTurn conversational control making the XYZ CT 65 HD ideal for both experienced and novice CNC users.

The new XYZ CT 65 HD is perfect for the subcontractor who doesn't know what job or material is coming next. This 2 axis machine and a CNC Milling machine or VMC can often be a more versatile and cost effective combination, than buying a Turning Centre with Y axis or live tool turret.

### All available with...



Mobile robotic automation for milling and turning centres

The new XYZ CT 65 HD is one of five high quality Turning Centres available in the XYZ 2020 range.

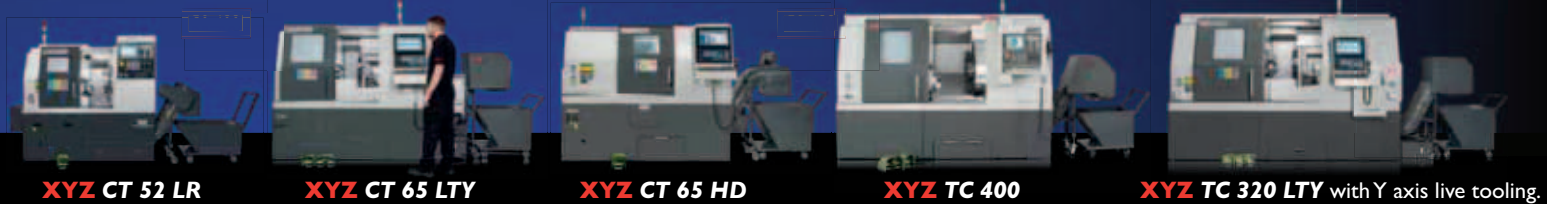

XYZ CT 52 LR

XYZ CT 65 LTY

XYZ CT 65 HD

XYZ TC 400

XYZ TC 320 LTY with Y axis live tooling.



**To learn more please call 01823 674200**

**MACHINE TOOL DEMOS ARE AVAILABLE AT ANY OF THE**



**NEW**

on all new **XYZ** CNC products  
**FREE TRAINING**

# The largest Protturn Lathe

## **XYZ** PROTURNS RLX 780

- PROTOTRAX RLX TOUCHSCREEN CONTROL.**
- SWING OVER BED 780mm.**
- SWING OVER CROSS SLIDE 535mm.**
- SWING IN GAP 1090mm.**
- DISTANCE BC 3000mm.**
- SPINDLE MOTOR 43 HP /32 kW.**
- SPINDLE BORE 160mm (180mm option).**
- SPINDLE SPEED (2 ranges) 20-1300rpm.**
- WEIGHT 8600 kg.**

180 mm Spindle Bore Option.



By combining large capacity turning with the powerful easy to use ProtoTRAK touchscreen control this lathe will meet all your turning needs.

### With ProtoTRAK® touchscreen

The ProtoTRAK® RLX control is available across the entire ProTurn range, from small lathes through to this three metre between centres lathe. The RLX control can be used manually or under full CNC control with clearance cycles, profiling, grooving, drilling, standard and custom thread routines and more. Call today to book your demo.



**Rear Chuck and Adaptor**  
The balanced rear chuck option on the **XYZ PROTURNS RLX 780** gives you better support of the part on longer components or tube.

The new **XYZ PROTURNS RLX 780** is one of eight high quality Prototrak controlled lathes available in the **XYZ 2020** range.



**XYZ RLX 1630**



**XYZ RLX 355**



**XYZ RLX 425 2 metre**



**XYZ RLX 555 1.75 metres**



**XYZ RLX 555** with various bed lengths.

[sales@xyzmachinetools.com](mailto:sales@xyzmachinetools.com)

[www.xyzmachinetools.com](http://www.xyzmachinetools.com)

**XYZ UK SHOWROOMS DEVON NUNEATON SHEFFIELD & LONDON**

opening soon

**ALL IN UK STOCK NOW**

# YOUR FIRST 5 AXIS MACHINE VM10Ui

The smallest of more than 20  
Hurco 5 axis models

5 axis simultaneous,  
standard feature

Easy five-side,  
conversational programming

Simple conversational rotary  
programming

Tiny machine footprint

Suits work 200mm cube

10,000RPM spindle

Available from £69,950  
for a limited period



Check out our new website at [www.hurco.com](http://www.hurco.com)  
Machine offers and Used Listings updated daily  
Download the latest 2020 brochures

**CALL 01494 442222 NOW FOR MORE INFORMATION**

MACHINING CENTRES

TURNING CENTRES

5 AXIS

DOUBLE COLUMN

SUPERIOR CONTROLS

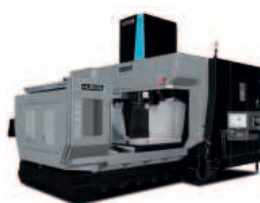

**HURCO**  
EUROPE

12 Merlin Centre • Lancaster Road • Cressex Business Park  
High Wycombe • Buckinghamshire • HP12 3TB • Tel: (01494) 442222  
[sales@hurco.com](mailto:sales@hurco.com) • [service@hurco.com](mailto:service@hurco.com) • [www.hurco.com](http://www.hurco.com)



Visit our website at:  
[www.engineeringsubcontractor.com](http://www.engineeringsubcontractor.com)

**CONTENTS**

<b>NEWS</b>	<b>6</b>
<b>AEROSPACE REPORT</b>	<b>8</b>
<b>METAL CUTTING</b>	<b>14</b>
<b>FEATURE - AUTOMATION</b>	<b>22</b>
<b>CUTTING TOOLS</b>	<b>30</b>
<b>FEATURE - WORKHOLDING</b>	<b>34</b>
<b>ADVANCED MANUFACTURING</b>	<b>42</b>
<b>FEATURE - MEASUREMENT &amp; INSPECTION</b>	<b>46</b>
<b>CADCAM</b>	<b>52</b>
<b>FEATURE - WATERJET MACHINING</b>	<b>56</b>
<b>METAL FORMING</b>	<b>64</b>

**NEXT ISSUE OCTOBER**

- 5-AXIS MACHINING
- ADVANCED MANUFACTURING
  - CUTTING TOOLS
  - LUBRICATION
  - METAL MARKING
- SAWING & CUTTING OFF

Published by Roger Barber Publishing  
Enterprise House, Foundry Lane, Horsham, West Sussex, RH13 5PX  
Tel: 01403 266022

Publisher: Roger Barber  
Email: [roger@rbpublishing.co.uk](mailto:roger@rbpublishing.co.uk)

Editor: John Barber - 01403 266022  
Email: [john@rbpublishing.co.uk](mailto:john@rbpublishing.co.uk)

Accounts: Jackie Barber - 01403 563791

Production manager: Anna Rodrigues - 01472 210712  
Email: [studio@rbpublishing.co.uk](mailto:studio@rbpublishing.co.uk)

Design & Production: Roger Barber Publishing  
Print: Holbrooks Printers Ltd, Portsmouth, Hampshire

Engineering Subcontractor is mailed to a controlled circulation of readers with a legitimate interest in the content. Roger Barber Publishing stores all business data securely and does not share with third parties.

No part of this publication may be reproduced without express written permission.

## Implementation lead-time and piece part cost are fundamental in aerospace subcontracting

Within the aerospace subcontract machining sector, businesses face a protracted and complex bidding process, with negotiations taking a long time before contracts are finalised. The date for start of production set by the prime or a higher tier firm in the supply chain often remains unchanged, which means that engineering implementation time from go-ahead to project commencement is compressed.

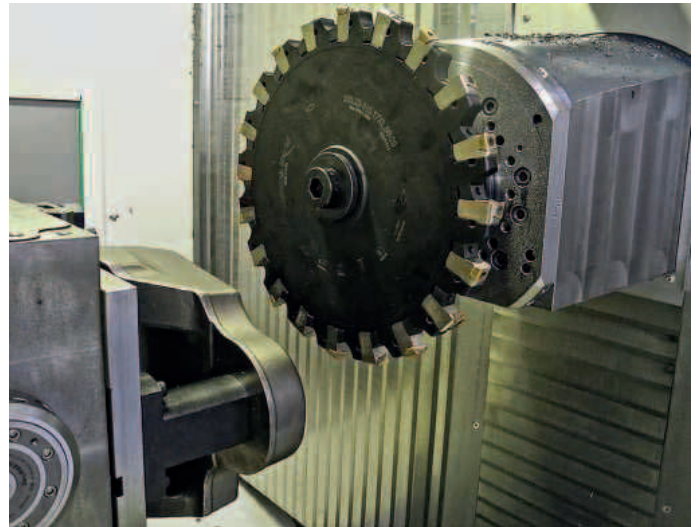

To address the problem, Heller Machine Tools, whose factory in Redditch produces 4-axis and 5-axis horizontal machining centres for world markets, has joined forces with Alcester-based Seco Tools (UK) to speed the implementation and delivery of turnkey machining cells, particularly for the highly efficient machining of titanium, nickel-based alloys and other difficult-to-cut metals.

In this connection, it is noteworthy that Seco opened its first-ever global innovation hub at the end of last year devoted to developing advanced processes for machining aerospace components. In a further development, a Heller H6000 horizontal machining centre having a 12,000 rpm, HSK100 spindle with over 2,200 Nm of torque and an integral camera was added on permanent loan to the array of machine tools from different suppliers available for cutting demonstrations in Alcester.

For a machine tool builder and tooling supplier to successfully deliver a turnkey project in a short lead-time requires a close collaborative effort and seamless project management between the parties. Needed also are the requisite knowledge and experience of developing production processes, together with software tools for NC programming and cycle verification, plus infrastructure to produce often complex fixtures, carry out cutting trials and prove each step of the process in parallel with the turnkey design, while continuously feeding back relevant test data.

Initial discussions between a subcontractor and a machining solution provider centres on achieving the necessary cycle times across the range of parts to be produced in order to achieve the contractual piece part cost (PPC) and the required profit margin. Heller uses advanced simulation within Siemens NX to check the estimated cycle time and also exploits machine simulation within Vericut.

Story continues on page 8-9

# BIG KAISER wins Global Industry Award 2020

The BIG KAISER brand that is available in the UK from technology partner Industrial Tooling Corporation (ITC), has always stood head and shoulders above rival products in terms of quality, precision and innovation. This has now been recognised with BIG KAISER and its new EWA fully automatic fine boring tool winning the 'production performance' category in the prestigious Global Industry Awards 2020.

Entered for the award through Boulland DPM, BIG KAISER's partner in France, the production performance category highlights innovations focusing on the significant improvement of key metrics or performance through productivity gains.

Giampaolo Roccatello, head of sales and marketing at BIG KAISER, says: "We congratulate and thank Boulland DPM and are delighted that the EWA and its pioneering role towards Industry 4.0 implementation has been recognised with this prestigious award."

The EWA is an intelligent, fully automatic fine boring tool that does not require human intervention. It achieves fast, accurate boring, as the process does not need to be stopped to check measurements or manually adjust the fine boring tool. As well as saving time, this minimises costly scrap resulting from manual adjustment errors.

The new EWA features a powerful motor for robustness and reliability. It is sealed against dirt and water in accordance with IP69. The clamping system provides additional stability and repeatability to deliver consistently high reliability and precision at cutting speeds above 200 m/min.

Jose Fenollosa, head of research & development at BIG KAISER, says: "The EWA is far ahead of the rest in its level of



automation and sophistication. This gives our customers real benefits in terms of time and money saved and this makes it ideal for Industry 4.0 applications. We are talking to potential customers now, including some of the leading machine tool manufacturers. The final EWA product will be available in 2020."

### The available configurations

The EWA can be used in three primary configurations: tablet, PC and fully integrated control systems. The EWA features wireless connectivity to BIG KAISER's user-friendly smartphone and tablet app for easier tool monitoring and configuration. It can also automatically communicate with a presetter, so diameter measurements can be transferred without operator intervention via a tablet or App enabled device.

For legacy machine tools, a PC interface between the machine tool and the EWA can be used to provide a fully-automated, closed-loop control cycle. This is suitable for instances where commands are sent from the machine tool to the EWA, as the system can automatically adjust or stop the machining process as and when required. For the next generation of machine tools, the BIG KAISER EWA control software can offer a fully integrated system whereby the

system will run directly on the machine tool itself to provide an equivalent level of automatic control, requiring no external control device.

At EMO 2019, the EWA was demonstrated working in-situ with a FANUC CNC machine with the entire boring cycle performed automatically. The configuration was undertaking initial boring, then measuring it and then adjusting the tool to complete the final precision bore.

The new EWA will initially be available in two variants. The EWA peripheral will cover diameters from 68 to 90 mm with the EWA



centric developed for smaller bores from 10 to 54 mm. Further models for different adjustment levels and diameter ranges are currently in the design phase and will be announced soon.

The EWA can be used with BIG KAISER's extensive range of accessories, making it easy to add to an existing system. To maximise flexibility, the EWA 68 model offers an adjustment range of 22 mm, which is substantially larger than similar solutions available in the market. The EWA has an integrated accelerometer that measures vibration during the cutting process. In the event of excessive vibrations, the EWA alerts the machine tool to automatically adjust its cutting parameters accordingly.

ITC will be updating customers as soon as this exciting innovation becomes available.



**Industrial Tooling Corporation Ltd**  
**Tel: 01827 304500**  
**Email: sales@itc-ltd.co.uk**  
**www.itc-ltd.co.uk**



# FARO launches latest 3D portable CMM

FARO Technologies, Inc, the global leader for 3D measurement, imaging and realisation solutions for 3D Metrology, AEC, and Public Safety Analytics, has announced the release of its most affordable and accurate 3D portable coordinate measurement machine (CMM), the FARO Gage.

Ideal for small and medium-sized businesses performing high-accuracy tasks, the Gage is the most intuitive, ergonomic, and versatile articulated portable FaroArm®, enabling machine shops to perform their most demanding 3D inspections in record time.

The all-in-one-solution also reduces calibration costs and minimises clutter, replacing traditional hand tools such as calipers, micrometres, and height gauges, while providing 20 percent more reach than the previous-generation Gage arm. Lightweight and portable but with the precision of a lab instrument and the ruggedness of a shop floor device, the Gage sets up in seconds, reduces inspection time, and delivers quality results with exceptional flexibility, resulting in increased speed and productivity.

As the United States and the world begin emerging from the COVID-19 pandemic, the value proposition for such a product could not be clearer. While global industry is presently suppressed, economists predict a robust recovery by Q3 and Q4. That means that many machine shops now operating at half speed will rapidly ramp up production. Demand will surge and products will require fast-tracked release.

The FARO Gage achieves this aim by improving efficiency and productivity as never before.

The efficiency begins with setup. A universal quick mount ensures compatibility with a variety of

mounting options that allows it to be set up anywhere, including on-machine. A simple 2-button design, 6-point articulation and built-in counterbalance deliver exceptional ease of use and fatigue-free operation. Its compact design makes the product lightweight and easy to transport. The Gage is compatible with FARO's full line of metrology software, including CAM2 Probing, the simple contact measurement solution. The result is an advanced metrology device that delivers unparalleled performance.

**FARO Technologies UK Ltd Tel: 024 76 217690**

**Email: [uk@faro-europe.com](mailto:uk@faro-europe.com) [www.faro.com](http://www.faro.com)**



 **Hoffmann Group®**

**ENABLING UK MANUFACTURING  
AND BRITISH INDUSTRY**

**[ EXPECT  
MORE ]**

**MAKING YOU MORE SUCCESSFUL  
BY INCREASING PRODUCTIVITY  
AND REDUCING COSTS**

Machining | Clamping | Metrology | Cutting and Grinding  
Hand Tools | Power Tools | Workstations and Storage  
Workshop Accessories and Consumables  
Personal Protective Equipment | Spill Control

Tel: 0121 716 4301

Email: [ab.uk@hoffmann-group.com](mailto:ab.uk@hoffmann-group.com)

## Implementation lead-time and piece part cost are fundamental in aerospace subcontracting

...continued from page 5

When results are compared to dry running on the machine, a correlation within five percent of actual cycle time is typical. It provides confidence that software cycle time predictions are consistent with those that have been promised. It is even possible to simulate leaving different amounts of stock on a component after roughing and before heat treatment, then compare those scenarios with removing varying amounts of metal during finishing. In this way, cycle times can be optimised and the subcontractor can benefit from time and cost savings.

These activities are backed by cutting trials at Heller's technology centre in Redditch using actual material samples to prove that tooling strategies achieve the required cutter life, surface finish and geometric quality as well as the predicted PPC. This activity has now been extended to the dedicated Heller H6000 facility at Seco in Alcester, offering customers the chance to prove cycle times and cutting parameters on a powerfully equipped machining centre for cutting titanium and other aerospace materials. All aspects of the workholding and cutting concepts can be fully tested and proven in parallel with the design phase to shorten critical lead-times during the turnkey process.

Critical to any project is defining at an early stage the PPC. Having the tools and models to calculate it accurately and monitor it during the design phase of a turnkey project is key to ensuring cost targets are met. Using proven cutting data and experience of historical tool life parameters, steps are taken to offer the customer a reliable PPC right from the beginning of a subcontractor's bidding phase.

This is constantly monitored throughout the turnkey engineering phase and any changes to tooling strategies and machining methods are fed back into the PPC model. In many cases, it is this model that drives changes to the machining process in order to machine certain features of a part most cost-effectively. Using cycle time simulation software, the process is optimised in a way that gives the subcontractor the best balance between machining time and PPC.



Through comprehensive testing and trial cutting on material samples, Heller and Seco are able to prove the reliability of the PPC model. The dedicated Heller machines in both the Heller and Seco facilities allow the proposed machining system in its entirety to be scrutinised rigorously and tested through each stage of the turnkey process.

Rigidity of the machine and fixture together with component rigidity can be tested using the recommended cutters, with tool paths generated and validated prior to running. Experience shows that the rigidity of the system as a whole when machining titanium has a significant influence on tool life and thus PPC. In trials, it has been possible to see the benefit that rigidity in the machine tool, workholding and cutters brings, with tool life often being 15 to 20 percent longer than expected.

### Feature-based challenges

With many aerospace components, there can be features inherent in the design that are awkward for a cutter to access. Large



clevis slots are an example where the correct tool and machining centre are important in ensuring that difficult features can be machined effectively. As part of its collaborative approach to working, Heller is able to specify the machine according to the demands placed on the Seco tooling.

An example of this is when using large diameter disc milling cutters at high material



removal rates. The low rotational speed of such cutters when processing titanium requires a very high torque spindle. Heller has a modular range of spindle types that can be selected according to the process demands. Using software to calculate the power and torque that a given operation requires and, with the ability to test such tools on a subcontractor's materials during cutting trials in Redditch or Alcester, it is possible to validate processes.

### Component accuracy and quality

Accuracy of machined parts is important in aerospace manufacture, especially for safety-critical structural components where tolerances on certain features often exceed those demanded in other sectors. Heller's experience has much to offer in this respect, an example being line boring of assembled pylons to tight tolerances to ensure accurate collinearity.

Traditionally, this type of operation would be carried out on a specific machine that has been tooled especially for the task, requiring a large amount of manual intervention to set up and run the cycle each time. The value of components at this stage in the production process is high and any risk of scrapage needs to be eliminated.

For one particular application, Heller developed a special fixture for line boring to ensure that the quality of the features could be guaranteed, irrespective of machine geometry. The fixture was designed and manufactured to extremely fine tolerances with integrated guide bushes. Tooling supplied by Seco incorporated a floating tool adaptor to connect with the fixture bushes. A special NC program sequence to insert the boring bar was created to ensure that it engaged with the fixture bushing and that the bar could be retracted to perform the machining operation through all bores in a clevis.

The approach developed by Heller and Seco led to a number of ongoing advantages in the customer's Flexible Manufacturing System (FMS). As it is a pull-boring operation, there are no retract marks left in the component and the workholding entirely dictates part accuracy, making it independent of machine geometry.

### Process security

Producing complex, high value parts in titanium requires an elevated level of process security. Workholding design is important to ensure that parts are clamped

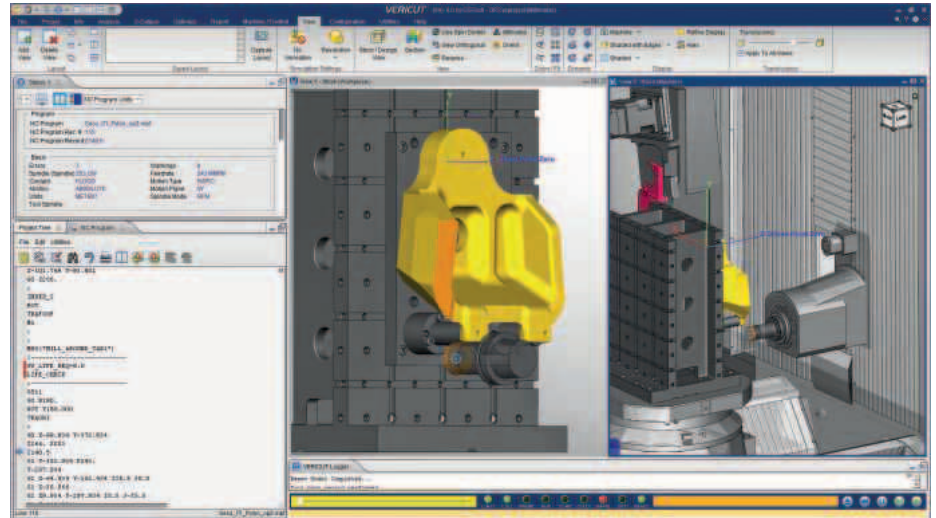

during machining with maximum force, whilst preventing any distortion. Heller has a wealth of experience in designing fixtures that meet these challenges using work supports and damping devices. During the design phase, supports are added where considered necessary and during trials and validation cutting, additional supports can be designed and implemented quickly.

To add extra process security, probing can check that machined features are dimensionally correct. To ensure tooling is set correctly, Heller offers the option of a Balluff memory chip, which is of particular importance when machining titanium as tool life expires more quickly than when dealing with other materials.

### Automation for lights-out running

To get the most from investment in a machine tool and to minimise labour costs, lights-out production offers manufacturers an attractive, cost-saving benefit by increasing the efficiency of the production cell. Relatively long cycle times when machining titanium offer an ideal opportunity to exploit the benefits of unattended running.

Heller offers a number of automation options. Where a range of components has to be machined, an FMS provides key benefits for unattended working. Utilising multiple pallets in an automatic storage and retrieval system to fixture numerous components, machines can be kept busy throughout the night, so components are ready for further processing at the start of the next attended shift.

The machine tool OEM's expertise goes beyond automated loading and unloading of pallets carrying pre-fixture parts. The entire machining system and logic are given careful consideration to ensure that the

production planning requirements can be met with the resources available within the cell. Heller and Seco have worked closely to ensure that tool contact times are accurately recorded in the NC program so the software within the automation system is able to plan tooling availability for any given pallet of parts.

Any automated system running lights-out for prolonged periods should have a degree of monitoring built in and Heller has worked closely with leading automation companies to offer this.

The overall message is that the distribution partnership agreement between Heller Machine Tools and Seco Tools (UK) brings far-reaching benefits to subcontractors in aerospace supply chains.

Matthias Meyer, managing director of Heller in Redditch, says: "Close collaboration between a machine tool company and a tooling specialist is the only way to really drive forward significant advances in metalcutting that lead to double-digit increases in productivity. It is very difficult for either party in isolation to develop solutions that achieve this level of improvement and to answer customers' questions comprehensively."

David Magnall, innovation partnership manager at Seco, adds: "We have been working closely with Heller for some time and have already jointly developed cutting strategies that have achieved process time improvements of 50 percent for one aerospace customer, as well as longer tool life."

**Heller Machine Tools Ltd**  
**Tel: 0121 275 3300**  
**Email: sales.uk@heller.biz**  
**www.heller.biz/uk**

## ROCOL gets the aero industry ready for take-off

The aerospace industry is certainly facing a turbulent time at present with fleets grounded for extended periods as a result of the COVID-19 pandemic. With such a large investment portfolio grounded, airlines and MRO vendors must maximise this time to maintain and prepare their fleets for that time we've all been waiting for; the lifting of worldwide restrictions.

ROCOL appreciates the concern of multi-million or billion-pound fleets being grounded. After all, you wouldn't leave your family car for weeks without giving it a run. As a lubrication specialist that first supplied products to Rolls-Royce aero engines almost 100 years ago, ROCOL is the globally recognised partner that provides the performance you can trust. Since that first collaboration with Rolls-Royce, ROCOL has been serving the aero industry with lubricants, corrosion protection products and fluid solutions that are approved by operators like Boeing, Airbus and NATO.

Now, more than ever is a time to see what ROCOL can provide for your fleet and its MRO needs. To ensure that maintenance repair costs are minimised and assets returned to the skies faster than ever before, ROCOL has introduced its AEROSPEC Protect Spray. This heavy-duty waxy film spray for long-term corrosion protection is Airbus approved and it is the perfect partner for components in outdoor and harsh environments. Perfect for landing gear, axle



sleeves, hinges and gearbox casings, AEROSPEC Protect spray is temperature resistant from -40°C to +120°C. Resistant to fuel, oil, de-icer fluids and water, AEROSPEC Protect Spray creates a tenacious highly-adhesive long-lasting film for astounding corrosion protection.

Complementing AEROSPEC Protect Spray is PX32 military-grade corrosion preventative that preserves structural members and airframes and interior surfaces such as skins, components and bare-metal features. Ideal for outdoor corrosion protection, PX32 solution provides outdoor protection for up to two years in temperatures from -40°C to +110 °C. resistant to anti-icing and de-icing solutions, PX32 is resistant to removal by exterior aircraft cleaner and it does not contain silicones or chlorinated solvents. With properties similar to PX32, PX28 corrosion preventative has been adapted for the preservation of interior sections of artillery components and the underbody of military vehicles. Like PX32, PX28 gives users the confidence that surfaces are protected for up to two years.

Another solution that will prove of huge significance to the aerospace industry is Z30. It is available as both spray and fluid formats in cans from 300 ml or in 5 or 20-litre containers. Perfect for protecting machinery parts and equipment from corrosion, Z30 is a heavy-duty wax film that is equally well suited to internal and external conditions. Offering unparalleled protection, Z30 can also provide a light lubricating film that

protects in external environments for up to two years. For further details on any of these civil and defence aerospace product lines, please contact one of the team at ROCOL.

ROCOL is part of ITW, a multi-national US owned, Fortune 150 company. It develops, manufactures and markets technically advanced industrial lubricants and line marking systems to industries worldwide.

ROCOL was founded upon the work of Victor Ivanovitch Ragosine, born in Russia, who took a degree in chemistry at the University of Moscow in 1854.

Based in Leeds, UK, the origins of the company date back to 1878 when Victor Ragosine developed a yellow lubricating oil which he subsequently sold throughout Europe. Unlike other lubricating methods the yellow oil was virtually non-corrosive making it technically superior to other products available.

In 1882, the UK agency manager Ernest Glehn bought out Victor and the Russian parent company and established Ragosine and Company, later to be developed into ROCOL.

While the company has made significant advances over the years, its ethos remains the same-to create highly technical products of superior quality to the competition, giving you performance you can trust.

**ROCOL**

**Tel: 0113 232 2600**

**Email: [shaun.heys@rocol.com](mailto:shaun.heys@rocol.com)**

**[www.rocol.com](http://www.rocol.com)**







*SMOOTH Ai*

# INTRODUCING THE **VARIAXIS C-600**

High accuracy, simultaneous 5-axis machining centre

The high-accuracy simultaneous 5-axis vertical machining centre, the VARIAXIS C-600, is suitable for a wide range of sectors, including the aerospace and automotive markets. The compact machine is characterised by its highly agile performance, with no compromise on rigidity. Most importantly, the new machining centre comes with a class-leading range of specification options, enabling machine users to configure the VARIAXIS C-600 to match their specific application.

Discover how we can help you deliver more.

Call +44 (0) 1905 755 755 or email [info@mazak.co.uk](mailto:info@mazak.co.uk)



No app required – just use your mobile camera

DISCOVER **MORE** WITH MAZAK™

[www.mazakeu.co.uk](http://www.mazakeu.co.uk)

**Mazak**  
Your Partner for Innovation

# May the force and speed be with you

Starrag UK has announced a host of innovative improvements to its Ecospeed and Ecoforce machines, for aluminium and titanium aerostructural component machining respectively, to improve cutting performance in terms of both reduced cycle times as well as the highly consistent production of high-quality components.

The developments include: a more powerful spindle, 150 kW for the Ecospeeds, for even higher productivity; enhanced software routines, for example, for optimised chatter control and adaptive jerk feed control on both Ecospeeds and Ecoforces; new pallet options on the Ecoforce Ti 9 and Ti 13 models, to accommodate ever-increasing workpieces sizes, particularly in structural aerospace components.

Starrag is also promoting enormous cost benefits through the use of MQL (Minimum Quantity Lubrication) as opposed to conventional flood coolant, with users obtaining at least three-fold savings primarily through eliminating the need for coolant-related maintenance and recovery systems.

The use of MQL rather than conventional cutting fluid, on any machine in Starrag's comprehensive range, is heavily promoted for aluminium machining. It is suggested that if MQL is used at 100 ml/hour, 16 hours/day for six days a week and 50 weeks of a year, the total operating cost of Euro 10,000 dwarfs the Euro 30,000 spent on conventional coolant year after year. In addition, the difference in capital investment for the different systems is even greater.

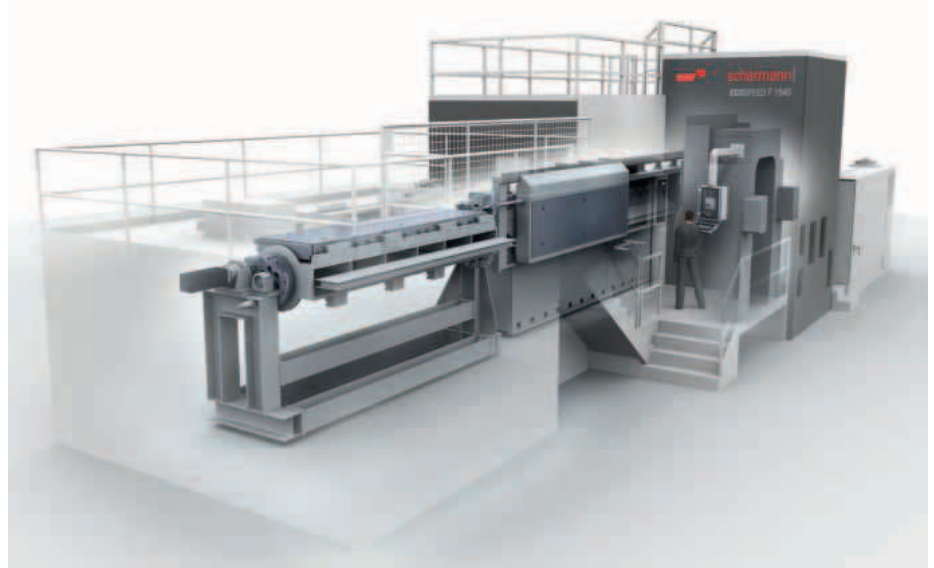

The machines' continual evolution, underpinned by Starrag's mantra of 'Engineering precisely what you value', is the result of the constant investigations by Starrag's expert product specialists and engineering teams into machine attributes and process improvements that will enhance overall machine performance in the most cost-effective manner.

Starrag also offers a superlative level of customer service, based on a team of customer-facing service specialists, as well as dedicated on-site engineers for appropriate installations. The net effect is that users of stand-alone machines through to minimally-manned flexible manufacturing systems enjoy guaranteed 95 percent uptimes.

The Ecospeed variants built to date, with pallet sizes from 1 m x 1 m to 2.5 m x 22 m, are renowned the world over for their unrivalled cutting performance in aluminium. For instance, an Ecospeed can convert a 4,100 kgs aluminium billet into a 123 kgs complex structural wing part in less than 20 hours when the machine is running at a maximum cutting volume of up to 10,000 cm<sup>3</sup>/min.

Now, says Starrag, such achievements

can be further enhanced with the use of a 150 kW HSK A 63/80 spindle, which complements the existing 80 and 120 kW units, plus increased drawbar pressure to offer a metal removal rate of up to 12,000 cm<sup>3</sup> at speeds of up to 30,000 revs/min with 18 mm depths of cut.

Another new Ecospeed development is the introduction of a 'standard' F1540 model which is designed for installation onto a flat floor without the need for a complex foundation. This model comes with a two-position automatic pallet changer, but it is also possible to integrate the model into a flexible manufacturing system, either from the outset or conversion at a later date.

Other developments for the Ecospeed F series machines include the use of four drives for all sizes, instead of three on the 2 x 4 m version, on the worktable, for manoeuvring fixtures/workpieces, alongside an upgraded drive train which enables higher feed and acceleration rates, improving these attributes by more than 20 percent.

Meanwhile, the new Ecoforce Ti 9 and Ti 13, 900 or 1.300 Nm torque machines specifically for titanium machining represent a 'coming together' of proven Starrag components, such as machine sub-assemblies and spindle, for the effective and efficient rough and finish machining of larger forged workpieces weighing up to 12,000 kgs on pallets of 4 to 6 m long and 2 m x 2.5 m wide.

Additionally, the ability to use shorter tools promotes higher stiffness and more stable cuts with high metal removal rates.





For example, roughing a Ti 6 Al 4V workpiece using a 80 mm diameter porcupine cutter at a surface speed of 75.5 m/min, a feed rate of 240 mm/min and a 100 mm depth of cut at 300 revs/min spindle speed, an Ecoforce can achieve an impressive metal removal rate of 816 cm<sup>3</sup>/min.

Effective spindle monitoring has always been a core functionality of Starrag's Integrated Production System (IPS), a modular digital platform that offers users a suite of functionality to meet individual tasks via the machines' HMI (Human Machine Interface). These include: Cloud-based solutions that analyze and optimise processes; the machine production system that monitors production in real time and protects the machine against incorrect operation/collisions and the machine qualification system that informs about machine condition and, when necessary, displays the appropriate maintenance instruction(s).

Vibration and chatter monitoring functionality are included here and while the former automatically identifies highly unbalanced tools and peak vibrations,

chatter monitoring automatically detects potential dangers to process stability. In addition, the machines' Siemens CNC's integrated inertia estimator permits adaptive jerk and acceleration settings, with jerk being automatically set according to actual payloads. This means faster cycle times as the workpiece becomes lighter during the machining process.

The machines' software now also incorporates functionality, embracing compensation strategies for tackling the effect of ambient temperature changes as well as the heat created by the cutting process, especially on aluminium workpieces, on component length and machine geometry.

All of these enhancements are part and parcel of Starrag's continual quest to present cost-effective solutions to customers' problems, as managing director Dr Bernhard Bringmann, emphasises: "The starting point for every Starrag solution is the component, not one of our machines. We vary machine configurations and machining concepts to determine the overall effect on cycle times; pushing

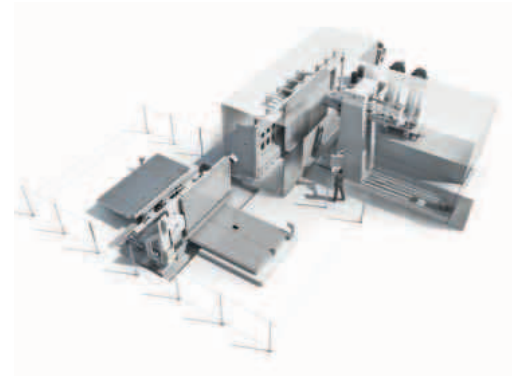

everything to the maximum to develop an all-embracing solution that is specific to each workpiece."

He concludes: "We are not in the market to sell 'standard' machines; we strive to continue to be the 'application champion' on specific parts required in either low or high volume. Our customers have to be competitive and, likewise, we have to remain focused on delivering cost-effective and efficient solutions time after time."

**Starrag UK Ltd**  
**Tel: 0121 359 3637**  
**Email: lee.scott@starrag.com**  
**www.starrag.com**

## The 5-axis machine you've always wanted is now available

### GENOS M460V-5AX

When customers asked us to bring an affordable, high-performance 5-axis machine to market, we accepted the challenge. The result is our new GENOS M460V-5AX, a next-generation vertical machining centre that offers unrivalled accuracy and productivity at an affordable price point.

**At Okuma, your feedback becomes our mission.**

Contact

NCMT Limited  
 Tel 020 8398 4277 Fax 020 8398 3631



www.ncmt.co.uk



## OPEN POSSIBILITIES



# Continuous improvement never stops

### Leading precision subcontractor invests in advanced Doosan multi-tasking mill-turn machine tool during the lockdown

Mills CNC, the exclusive distributor of Doosan machine tools in the UK and Ireland, has supplied Cheltenham-based Ferrositi Ltd, a leading precision subcontract specialist, with a new, state-of-the-art mill-turn machine.

The Doosan SMX 2600S 13" quick-change chuck roller linear guideway multi-axis machine, was installed at Ferrositi's 18,000 sq ft facility in May 2020, a time when many companies were, understandably, battenning down the hatches. It comes equipped with left and right opposing spindles, 26 kW 4,000 rpm, a 240 degree B-axis milling spindle, 26 kW/12,000 rpm, Y-axis capability, ±150 mm, a servo-driven ATC, 40 position and the latest FANUC 31i control,

The investment made during the height of the pandemic outbreak is typical of Ferrositi, a company built on innovation and continuous improvement and one committed to delivering engineering excellence and best-in-class customer service.

Ferrositi's managing director Nick Furno says: "Ever since the company was created, in 2012, we have invested in multi-axis machine tools as a route to improving our productivity, operational efficiencies and competitiveness."

A quick tour of the company's sizeable machine shop provides ample evidence of its investment policy with a number of advanced, large-capacity 5-axis machining centres and lathes, with sub-spindles and full

mill-drill capabilities, in close proximity to one another.

Nick Furno continues: "We serve and operate in a number of global and highly-competitive sectors and industries such as aerospace, oil and gas, automated and special purpose machinery and high-profile architectural projects.

"Central to our success in these and other sectors has been our ability to machine high-quality components and deliver them to customers, on time, every time and within budget.

"The multi-axis machines we have at our disposal make us more efficient and enable us to make complex high-precision parts quicker, in fewer machining operations and, often, in one setup.

"We are always on the lookout to add to and strengthen our front-line machining resources."

Despite the lockdown, such an opportunity arose in April 2020 and resulted in Ferrositi making its first investment in Doosan machine tool technology and, coincidentally, its first mill-turn machine acquisition.

Nick Furno explains: "The Doosan SMX 2600S complements our existing machine tool portfolio.

"Both Doosan and Mills CNC have good reputations in the market and, when I was informed that a mill-turn machine was viable immediately, from Mills CNC stock, at a good, competitive price, I was interested."

Having seen the SMX 2600S at Mills

CNC's Technology Campus facility in Leamington the decision to purchase the machine was made.

Nick Furno concludes: "We have had the machine for about four weeks and, during this quieter-than-normal period, are spending time familiarising ourselves with its operations, functionality and its latest Fanuc control.

"Already we can see and appreciate that the machine is powerful, fast, flexible and accurate. We are particularly impressed with its rigidity, ergonomic design and thermal stability.

"Using a single setup, the SMX is capable of performing multi machining processes. As a consequence, this means we can reduce production bottlenecks and limit stop-start operations.

"The SMX will help us consolidate and grow our position in existing supply chains and sectors, as well as helping us to spearhead our move into new sectors and industries such as machining components for the food processing and medical sectors."

Mills CNC is not your typical machine tool supplier. It is an independently owned company and its focus is on serving customers in the UK and Ireland, as opposed to Europe and/or the rest of the world.

This independence means it can make decisions and respond quickly to changing market trends, conditions and customer requirements. As it only serves the UK and Irish markets, the company has developed a good understanding of what customers need and want.

As the exclusive distributor of Doosan machine tools in the UK and Ireland, its product range, while being one of the most extensive in the market, is entirely Doosan. Consequently, everything Mills does is geared around ensuring the sale, service and support of Doosan machines and providing excellent customer service to customers that invest in them.

**Mills CNC Ltd**  
**Tel: 01926 736736**  
**Email: sales@millsnc.co.uk**  
**www.millsnc.co.uk**





# CITIZEN

ADVANCED CNC MACHINING TECHNOLOGY

LFV  
technology

LOW  
FREQUENCY  
VIBRATION  
TECHNOLOGY

TOUCH SCREEN  
TECHNOLOGY

INTELLIGENT OFFLINE  
PROGRAMMING  
SOFTWARE

LASER CUTTING  
TECHNOLOGY

ECO  
FUNCTION

## Tomorrow's technology today

Citizen machines bristle with the latest technology to ensure our customers are ready for tomorrow's challenges today.

- Touch screen nanotechnology, easy to use and ultra-high speed machine processing
- Citizen's innovative, industry-leading LFV technology – programmable chip control, guaranteed to increase productivity and increase tool life
- Eco Function – Citizen's 'Eco Function' automatically generates power to save energy, characterised by the new touch screen Eco Monitor to ensure the machine is running at peak efficiency
- Integrated laser cutting offers revolutionary high-speed cutting and generation of micro features

**Talk to our experts and discover how Citizen's innovative solutions help increase efficiency and boost your profitability.**

[citizenmachinery.co.uk](http://citizenmachinery.co.uk)

01923 691500

Cincom 

# Pendle Engineering plans for the long-term and takes delivery of its fourth XYZ machine

While the Covid-19 pandemic has caused unprecedented concern for many in the manufacturing sector, there remains an air of positivity, with machine orders continuing to be taken by XYZ Machine Tools. As a result, deliveries continue to take place on a daily basis to customers across the UK and further afield. A case in point is the recent dispatch of an XYZ 3010, the largest vertical machining centre in the XYZ range to Pendle Engineering based in Nelson, Lancashire.

The XYZ 3010, which weighs in at 25 tonnes, is the fourth XYZ machine purchased by the Nelson, Lancashire-based, fabrication and CNC machining specialist. Its decision to make an investment at this time was driven by the confidence it was seeing from its customers, while at the same time delivering a significant increase in machining capacity with its axis travels of 3,000 mm by 1,000 mm by 800 mm, backed by a 56 hp 8,000 revs/min spindle. Pendle Engineering now has the capability to machine pieces weighing up to 4,000 kg, with the machine's Y-axis supported by six box slideways to generate the support and rigidity required.

"At Pendle Engineering we are committed to delivering quality, service and value to our customers through our passion and our people. Our subcontract steel manufacturing services are supplied to a broad range of industry sectors and the encouraging levels of customer demand gave us the confidence to invest in the XYZ 3010, our fourth XYZ machine tool," says Chris Smith, managing director of Pendle Engineering. "This new machine not only bolsters our existing machining capacity but allows us to bring the machining of larger workpieces in-house. These unprecedented circumstances have without doubt added an extra dimension to our investment decision-making, but we are planning for the long term and are delighted to be working with XYZ Machine Tools once again."

XYZ Machine Tools has continued to support its customers throughout the pandemic and this has been rewarded by a steady influx of new machine orders. It currently has around 50 machines in build and under pre-delivery test at its Burlescombe factory, with deliveries being



fulfilled with machines from across its range, including ProtoTRAK mills and lathes through the VMC and turning centre ranges and its flagship UMC-5X 5-axis machining centre.

"It has been and continues to be, an unusual and difficult time for engineering companies and those that supply it," says Nigel Atherton, managing director, XYZ Machine Tools. "However, there has always remained an air of positivity and we are now beginning to see some expansion in business activity. Companies such as Pendle Engineering are showing the confidence to move their business forward through investment and we are happy to be able to continue our long-standing relationship with Chris and his team."

### ProtoTRAK update adds even greater ease-of-use

When the latest version of the world-leading



ProtoTRAK control system was introduced it brought with it a range of benefits to improve programming efficiency and ease-of-use, all based around the 15.6 inch touchscreen that put all of ProtoTRAK's advantages at the users' fingertips. As with all successful products, to maintain their advantage development has to be continuous, with the latest update ProtoTRAK users of the control on XYZ RMX Bed Mills can further simplify the programming of complex parts, such as islands in pockets.

New and existing users can take advantage of the islands in pockets feature by utilising the optional DXF converter, which can be added at time of ordering the machine or as a straightforward retrofit for existing XYZ RMX Bed Mills. With this option installed it is a simple process of importing the DXF file into the ProtoTRAK RMX control and the creation of the island program, for single or multiple islands in pockets, is created in the same easy way as any other machined feature in ProtoTRAK. The program toolpath can then be verified on-screen, with an estimated cycle time. For further reassurance a 3D solid model of the machined part can be generated.

**XYZ Machine Tools**

**Tel: 01823 674200**

**Email: [nigel.atherton@xyzmachinetools.com](mailto:nigel.atherton@xyzmachinetools.com)**

**[www.xyzmachinetools.com](http://www.xyzmachinetools.com)**





ROCOL®

ULTRACUT®

TRI-LOGIC®  
SYSTEM

RTD®

V-cut™

ULTRAFORM™

ULTRAGRIND™

Ultracare®

- ▶ Extend tooling and component life
- ▶ Reduce machine downtime
- ▶ Reduce tooling costs and breakages
- ▶ Increase productivity
- ▶ Minimise the risk of workpiece rejection and scrappage

[www.rocol.com](http://www.rocol.com)
 +44 (0)113 232 2600
 [customer.service@rocol.com](mailto:customer.service@rocol.com)

MANUAL MACHINE PLUS

# The new era in manual machining

The ultimate centre lathe with autocycling



**Adding automation into process**

- No CNC programming experience required and only minimal training need for existing centre lathe operators.
- Bridging the gap in the market between economy and performance by eliminating time consuming mechanical set-ups.**
- Precision, performance, reliability assured by using high accuracy ballscrew and servo linear drive systems and variable speed spindle drive with integrated CSS.

**Specifications**

- Swing over bed 330-554mm
- Distance between centres 635-3000mm
- Spindle bore 42-104mm



**Unique machine control system**

- In built machining cycles
- Easy to use touch screen operator interface
- Designed and developed by Colchester Machine Tool Solutions
- Ideal for one-offs and small batch production



Scan here for an exclusive preview



# Subcontractor stays loyal to Okuma

Before starting his own contract machining business, Mick Catherine worked for another subcontractor that was in the vanguard of using a Japanese-built Okuma horizontal machining centre to turn large, often eccentric components to within 10 microns dimensional accuracy.

Rather than employing a rotary table, the machine was programmed to 'turn-cut' the features with a single-point turning tool clamped in the spindle whose rotation was synchronised with the speed of circular interpolation in the X and Y axes, while the tool was fed forward in Z.

The advanced function in the machine's proprietary OSP control, together with the high quality of machine build and the proficient back-up provided by Okuma's UK agent, NCMT left a lasting impression on Mick Catherine.

So in 2017 when he opened CNC Subcon Services on the Meltham Mills Industrial Estate in Holmfirth, West Yorkshire, two early lathe purchases were a Genos L400 and an LB25-II, followed more recently by an MU-6300V-L 5-axis mill-turn centre, all manufactured by Okuma.

Mick Catherine says: "In 1989, I joined as an apprentice the subcontract machinists that later started using Okuma turn-cut technology.

"Since then I have gained a lot of experience, there and elsewhere, in producing parts in small quantities, particularly chassis, transoms, gearboxes and power transmissions for the rail industry.

"When I started CNC Subcon, I decided to specialise in providing technical expertise and advanced manufacturing solutions to the pump and valve sector, including product design. However, we work for clients in many other industries as well including defence, rail, marine, oil & gas and heavy plant & construction.

"Contracts typically involve machining ones and twos at competitive prices in quick lead-times, normally one week. I calculated recently that average batch size here is 1.2."

The firm operates seven days a week, often responding to urgent requests for replacement pump and impeller parts to repair customers' equipment that has broken down. More than £100,000 of material is held in stock, mainly steels including stainless but also plastics as well as



exotic alloys such as Inconel and Super Duplex. Any part, even damaged cast components, can be regenerated quickly from solid.

Paul Neville, sales and operations manager at CNC Subcon, states, "We continue to develop our own components and have a number of patents in place for systems that increase pump efficiency.

"For this and most of our subcontract work we need to machine to very close tolerances, for which top quality equipment like the Okuma MU-6300 mill-turn centre is essential.

"The rigidity of its bridge-type construction suits the machining of difficult materials. CNC Subcon is looking to be the best, so will only buy the best machines.

"With an Okuma you know there won't be any trouble. It places NCMT, with its reliable back-up and support, high on our list when it comes to new machine purchases."

The MU-6300V-L fitted with Okuma's OSP-P300SA control at CNC Subcon has a +90 / -120 degree trunnion carrying a 630 mm diameter table that can turn rotational parts up to 830 mm diameter by 550 mm tall at up to 800 rpm. The machine is

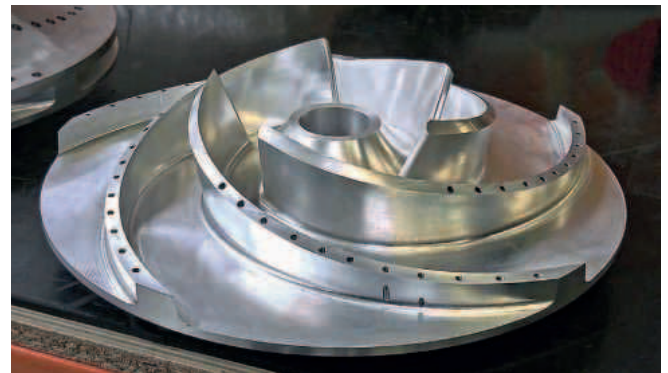

also able to mill and drill components within a 925 x 1,050 x 600 mm working envelope using fully interpolative 5-axis cycles. The HSK-A100 spindle is served by a 64-station tool magazine and is rated at 11/7.5 kW, with a maximum speed of 8,000 rpm.

Okuma's Thermo-Friendly Concept built into the machine, which applies to both the structure and the spindle, feeds data back from temperature sensors to the control. Continual compensation in the part program for thermal drift delivers high accuracy metalcutting in a shop floor environment, even if the ambient temperature varies by as much as 8°C.

**NCMT Ltd**  
**Tel: 020 8398 4277**  
**Email: daveburley@ncmt.co.uk**  
**www.ncmt.co.uk**



## ETG's Vulcan brand arrives

The Engineering Technology Group (ETG) has now launched an entirely new brand of high-quality cost-effective machine tools. The Vulcan brand has been entirely designed and developed by ETG to target the 'volume' sales market while complementing the company's existing high-end machine tool brands and turnkey solutions.

Already representing high-quality brands such as Chiron, Quaser, Nakamura, Hardinge and Bavius, ETG engineers have diligently worked with a trusted machine tool builder to develop a completely new range of machines with specifications, components, build-quality, performance and reliability all assured.

Commenting upon the launch of the new brand, ETG's group managing director Martin Doyle says: "We are delighted to introduce 'Vulcan' as our very own brand. We have worked tirelessly and diligently to create a range of machines that are designed 'from the ground up' by ETG. The pricing structure for such a high-quality brand of machine tools that will be

supported by ETG's service and support structure will certainly disrupt the UK's machine tool market."

Manufactured in Taiwan, the new brand from the Engineering Technology Group is the result of a longstanding relationship with a high-quality machine tool builder. ETG's Steve Brown says: "To enter the market segment where customers purchase machines at a particular price point, we wanted to ensure that we have the utmost in quality with a high specification machine construction that will give ETG a unique selling point. With a team of engineers permanently based in Taiwan to work in synergy with the machine tool builder, we can meet our core competence of ETG assured quality and performance at a price point that will appeal to every machine shop."

The Vulcan brand incorporates a series of seven precision turning centres with turning capacity for the very smallest parts to components beyond 1 m diameter and 5 m in length, all available with UK manufactured barfeeding solutions. The

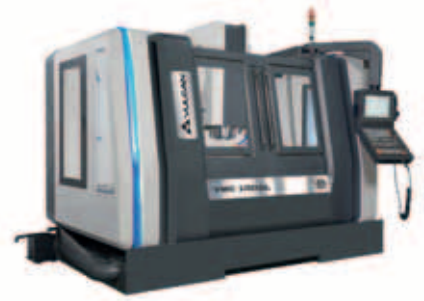

Vulcan machining centre offering is remarkably extensive with nine heavy-duty boxway VMCs that range from a table length of 800 mm to 2.6 m with many more models in the linear guide series for speed and precision. The Vulcan brand also incorporates double column boxway and linear machines with X-axis capacity up to 6 m and beyond an impressive 10 m respectively.

All machines are available from ETG with a comprehensive range of options.

**Engineering Technology Group**  
**Tel: 01926 818 418**  
**Email: sales@engtechgroup.com**  
**www.engtechgroup.com**

## PART EXCHANGE YOUR LATHE

FREE MACHINE VALUATION

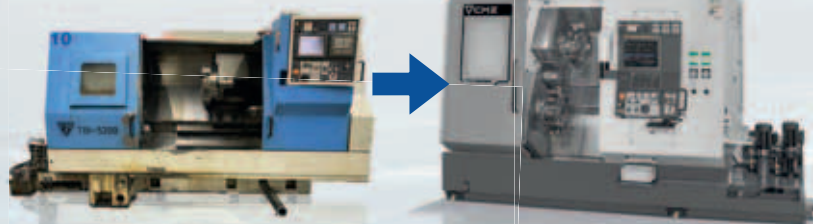

SAVE ON YOUR NEXT NEW MACHINE



**CMZ**

www.cmz.com  
 +44 (0) 1788 56 21 11



Scan the code  
**DISCOVER THE PROMOTION WITH YOUR CAMERA!**





# Floor space and efficiency as a key concept

The SwissNano 7 sliding headstock lathe has proven its worth for many customers and it excels in the machining of parts for the medical, dental, electronics and the micro-mechanics industries. It can optimise workpiece production in workshops, but how does it do this?

First and foremost is the floor space. This aspect is very eye-catching. With its length of 3 m and its 1 m width, the SwissNano 7 is extremely compact. This machine configuration even includes a high-pressure pump. So, a workshop can accommodate 10 machines on a floor space of less than 80 sq ms. Since the machines have spindles equipped with optimised motor drives, heat dissipation is very low. The workshop benefits from this in terms of reduced power consumption and less technical effort required to dissipate heat. For workshops with air conditioning, the electricity bill will be much lower.

To enhance the characteristics in terms of machine heating and dissipation, the spindles are equipped with an integrated cooling circuit. To optimise the thermal characteristics, both the spindles and the rotating guide bush are provided with ceramic bearings.

### Thermal behaviour

The SwissNano has short thermal circuits. This is the basis of a machine concept that mainly consists of a symmetrical cast-iron core that allows perfect control over thermal variations of the machine, with quite simple results. According to various customers interviewed, the stabilisation of the SwissNano 7 sliding headstock lathe takes

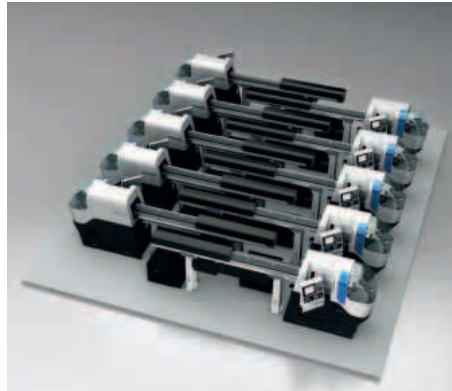

no more than 5 minutes, even under the most adverse conditions such as cold machine shops. So, this small machine can provide maximum productivity from the very first workpiece produced. In addition to its favourable thermal behaviour, the machine offers the utmost in rigidity. The wear resistance of the tools is excellent and permits cost savings and tool life enhancements of more than 30 percent. The structure of the machine and its base is simply perfect; it provides quick stabilisation and ultra-rigidity.

### Production efficiency

During the production process, the SwissNano 7 machine retains exceptional dimensional stability and the utmost in productivity levels. Thanks to its compact footprint, its tooling system and kinematic system enable the machine to achieve a higher productivity rate than more complex and more expensive machines. The differences have been instantly identified by one of the first customers of the SwissNano

7. They recognised how the SwissNano 7 produces 650 parts per shift and achieves a daily throughput of 1,300 workpieces, given the fact that the company is operating in 2 shifts. The previous machine from a famous European manufacturer of automatic lathes had two supplementary tool systems and a theoretically higher performance but could only produce 350 parts per shift.

In this case, the small SwissNano 7 is 85 percent faster. One could also say that the customer needs three competitor machines to achieve the annual production of one SwissNano 7 machine. Furthermore, the thermal stability ensures the SwissNano's scrap rate is much lower.

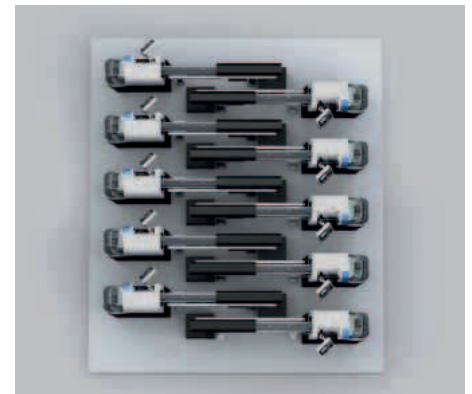

### Workpiece quality and unloading

Thanks to its pooled machining capabilities, the SwissNano 7 sliding headstock lathe allows a drastic scrap rate reduction. The extremely well-designed machine core contributes to the overall quality of the machine. Often, it is very difficult to unload parts correctly without damaging them. The SwissNano 7 offers an excellent solution.

It can be equipped with a vacuum system, a carousel that enables workpiece sorting and convenient statistical monitoring. The machine is suitable for all types of workpieces and the part outlet in the machining area can also be adapted to specific workpiece requirements. With its high performance, flexibility and efficiency, the SwissNano is an excellent choice for any machine shop manufacturing small precision turned parts whether they already use sliding headstock lathes or not.

**Tornos UK Ltd**  
**Tel: 01530 513100**  
**Email: sales\_uk@tornos.com**  
**www.tornos.com**

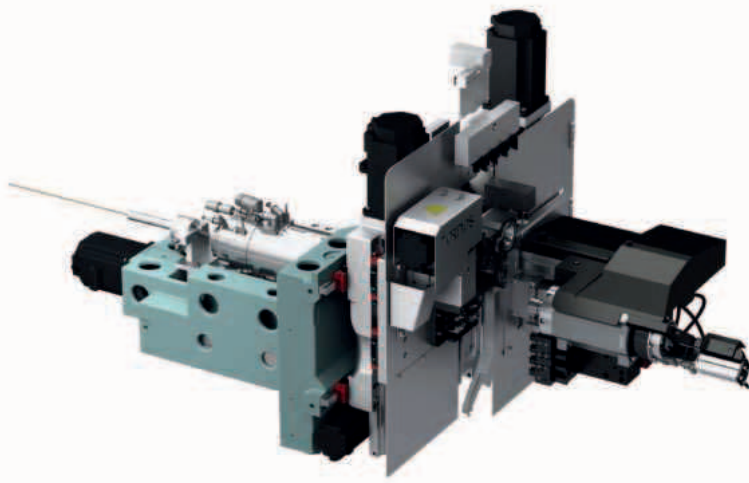

## Dugard provides heavy-duty solution for subcontractor

As a successful subcontract machining, fabricating, plating, NDT and assembly business, Rotherham-based ENS Precision Engineering Ltd expanded its interests with a move to a new 39,000 sq ft factory in 2018. Since moving to the new facility, the precision engineering company has purchased a Dugard HD1886B machining centre to increase its machining capacity and versatility.

The family business that is now based in Hellaby, on the outskirts of the South Yorkshire town, famed for its coal mining and steel production, is delighted with its purchase from the leading machine tool company.

Tim Atwell, director at ENS Precision Engineering, says: "We bought Dugard because it was a very competitive package with box guideways and a BT50 taper, which makes it a very rigid machine. Before buying the machine, we went to one of Dugard's customers and they were very pleased with the machine and that is always the best way to find out about the machine. This testimonial gave us the confidence to buy

from Dugard, which is a well-established company."

"While many companies go for very high rpm with a low depth of cut, at ENS we believe in using as much of the carbide as you can, going for bigger depths of cut. This is why we go for BT50 taper machines because they always have the grunt to push the carbide. The results are very good, and we have not had any issues so far."

Referring to buying the first Dugard machine from the Brighton-based machine-tool experts, Tim Atwell adds: "We had no reservations buying our first Dugard machine. Dugard is a long-established company and they are very honourable people. The only question for us was around the fact that we had never had that type of machine from Dugard. We had bought a different brand machine from them in the past, but it was a lathe. So, we just needed to know that the HD1886B could do the job and the backup was there."

Commenting on the new installation at ENS Precision Engineering, machine shop



operator and past apprentice, Josh Hipwell says: "We recently installed the machine and the main reason for the purchase was that our old machine was getting a little tired. We wanted a machining centre that could do all the work that our previous machine could do and more."

**C Dugard Ltd**  
**Tel: 01273 732286**  
**Email: sales@dugard.com**  
**www.dugard.com**

## Travelling steady with CMZ

Do you have to machine long and slender parts in your CNC lathe? Can you not avoid the appearance of vibrations?

The TD series of lathes from CMZ are ideal to machine this type of component. When equipped with a Travelling Steady, accuracy and surface finish can be maintained along the entire length of long and slender diameters, supporting shafts that would be next to impossible to turn without one.

CMZ offers high flexibility to customise the machine you need. For instance, it is possible to configure the number of steady rests and how they are driven. For the TD models with the longest bed lengths, it is possible to configure up to two steady rest bases, mounting one or two steadies per base. In case of mounting just one steady rest, it can be placed either on the left or on the right side of the base.

For the Travelling Steady application, a machine with one or two steady rest bases driven by servomotors is necessary. It is usually configured in conjunction with a

hydraulically driven tailstock and sometimes the latter can be "displaced" in order to enable the steady rest to move really close to the tailstock.

CMZ has been in the market for more than 70 years. Being part of an ever-changing sector, like machine tools has, enabled the company to improve its production processes with the purpose of offering the very best CNC lathes.

During this time, it has improved its manufacturing process. It produces strong, precise and reliable machines. The secret of the lathes is inside them; the company manufactures practically all its parts. This has helped it to acquire a very broad and professional vision of the product.

Another key component of the company's success is in its after-sales service. It has a friendly technical assistance service that

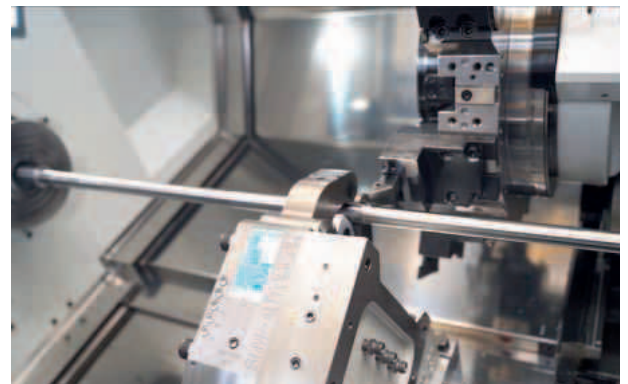

makes every effort to ensure the machines are synonymous with quality. The result? Machines with a life cycle of more than 20 years. In this time, CMZ stays close to its clients and is available to resolve issues and to provide advice and training.

**CMZ UK Ltd**  
**Tel: 01788 562111**  
**Email: info@cmz.co.uk**  
**www.cmz.com**

# EROWA's Smart Factory gets even bigger

For over 30 years EROWA has been providing factory automation to the various global manufacturing industry sectors and at this year's MACH 2020 exhibition, which is now rescheduled to January 2021, the company was due to highlight its Flexible Manufacturing Concept using automation as part of a smart factory installation. With robot systems capable of handling small workpieces from a few kilos to large parts up to 4 tonnes, EROWA is shining the spotlight on its ability to 'Go Large and Heavy'.

Offering around-the-clock running for machine tools producing heavier components, up to 4,000 kg, the EROWA LoadMaster Compact range provides exceptional reliability and robust operation. Each LoadMaster can cater for a variety of component sizes set to ideally match the spread of workpieces that customers' machine shops have to tackle.

The LoadMaster Compact highlights how easy it is to load raw material billets, cast or forged components into the multitiered storage system ready for unattended milling and turning. Finish machined parts can be removed via the ergonomic workstations or returned to the layered racking for retrieval when required.

The new LoadMaster range builds on the company's renowned reputation for precision and quality to offer automatic loading and unloading of large workpieces. With the exceptional return on investment

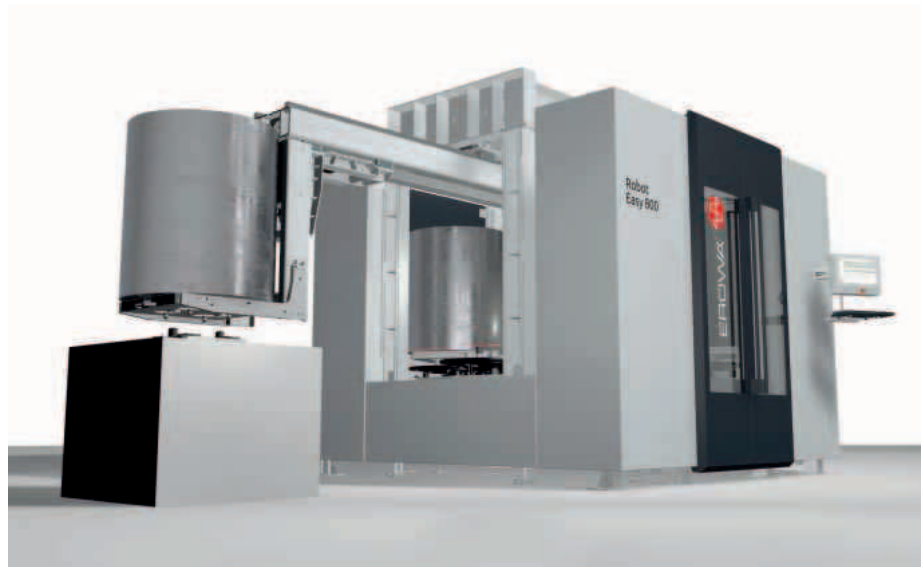

that customers have come to expect, thanks to the ingenious kinetic system with very limited space requirement. With the 360° swivel function, any position in the magazine and on the machine tables can be reliably reached.

The magazines are of vertical design; the storage positions are arranged over two, three or four levels, saving on space and cost. Each level is optimally configured for typical workpiece sizes. The magazine modules can be combined in series. So, there are no limits on the number of units that can be connected, and the total rail length depends on the number of machines and their positioning.

With walk-in or accessible via sliding doors the setup stations are integral components of the LoadMaster production lines. Versions are available with lifting unit, with rotating and tilting table, or with indexing table. The setup positions are also accessible via overhead crane.

EROWA's 'Pilot' control software makes schedule control, tool and job management very straightforward. It assists the operator in the daily production flow, with clear displays of system status.

Mixed pallet sizes in a production line allow optimal use of the available space and for systems with different pallet sizes the 'MultiFork' gripper is an efficient alternative







to changing individual grippers. The gripper width smoothly adapts to different pallet dimensions. Solid, robust technology for large workpieces.

For workshops where space is at a premium, the EROWA Easy 800 keeps it tight. Launched at EMO last year, the automation specialist's rationale for the Easy 800 is intended to support the efficient machining of larger components. Capable of deploying heavier workpieces on larger pallets, but within a minimal footprint, the Easy 800 offers a significant increase in the size of the raw material or part finished components that can be accommodated, up to 850 mm diameter and up to 1,000 mm in height with six stations.

"The impetus from the manufacturing industry has been for larger, more complex machine tools and now these can be fully automated with the Easy 800," explains managing director Ian Holbeche. "Using the EROWA 'Flexible Manufacturing Concept' (FMC) customers equipped with an automation system can typically increase productivity by a factor of five using various manufacturing technology, including die sinking EDM, multi axis milling and turning, as well as measurement and inspection."

EROWA's goal of increasing the

productivity of machine tools, using its FMC philosophy, is based on its automation systems and the four steps to follow to achieve the maximum number of working hours, up to an incredible 8,760 hours per year, from any machine.

Ian Holbeche explains: "Maximising the number of hours on your existing machine tools before you invest in your next machine can saving you time and money. EROWA has the ability to retrofit automation systems to existing standalone machine tools and even manufacturing cells, so the advantages and benefits are available to just about any manufacturing business."

REM Systems was established in the early eighties to service Swiss EDM machines. This activity brought the company into contact with the Swiss tooling and automation company Erowa and it has been its distributor in the UK and Ireland since 1987.

At about the same time, it also became the distributor for another Swiss company, TRIAG that produces multi-vice systems. Recently it became the distributor for a third Swiss company, FTool that manufactures EDM tooling systems. REM Systems association with these companies, coupled with many years' experience of machine

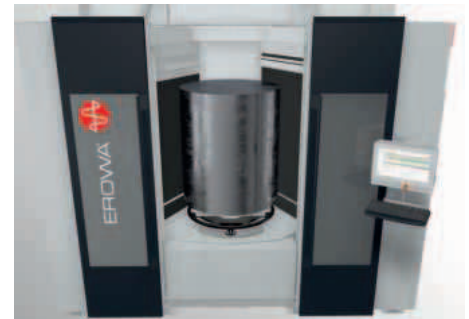

tools and production engineering, means it is well placed to help customers in their pursuit of lean manufacturing processes.

From the very start its goal has been to create and deliver solutions for most applications in the precision metal cutting industry sectors by the development, production, consultation and distribution of modern manufacturing technology.

Today, it offers and supports a universal product range; from tooling systems to full automation systems, as well as process control software for every industry sector looking to machine metals efficiently.

**REM Systems Erowa**  
**Tel: 01452 750581**  
**Email: sales@remsystems.co.uk**  
**www.remsystems.co.uk**

## Exoskeletons will transform manufacturing

A Paris-based start-up recently helped a woman with partial paralysis to use an exoskeleton to walk. Breakthroughs like this are allowing exoskeleton technology to be used in more varied environments, with potential benefits for manufacturers. Here Neil Ballinger, head of EMEA sales at industrial automation parts supplier EU Automation, explains how exoskeletons will transform manufacturing

It is common for manufacturers to use robots to carry out repetitive tasks, often in hostile environments. But what if these environments are also hostile to robots? Also, how do you protect an ageing workforce from the heavy physical workload, repetitive movements and non-ergonomic postures which undermine productivity? Exoskeletal technology now has an answer for this.

Consisting of a metal frame fitted with motorised muscles to the outside of your body, a wearable robot, more commonly known as an exoskeleton, can multiply its user's strength and enable workers to carry out a variety of industrial tasks. Applications range from muscle support for rehabilitation to industrial suits, which allow you to lift heavy weights with next to no effort.

### A tailored suit

The global exoskeleton market size was valued at \$25.4 million in 2015 and is projected to grow at a CAGR of 58.4 percent between 2018-2025. Apart from the obvious medical and healthcare use, demand is being driven for exoskeletons in military and industrial use too.

The prevalence of different types of stationary and mobile exoskeletons, driven by pneumatic, hydraulic and electric actuation and powered by fuel cells, batteries, or mains power, makes it vital that manufacturers know what's best for them. To meet the demanding needs of industrial applications, plant managers should choose exoskeletons that are lightweight, comfortable, safe as well as minimally invasive to the surrounding environment.

Plenty of options are available to manufacturers. For instance, many companies are now developing single-joint wearable robotics rather than full body powered suits which tend to be heavier and more obstructive. Upper extremity exoskeletons, such as Ottobock's Paexo, provide support to the upper body, arms and shoulders. Meanwhile, lower extremity models provide support to the legs, hips and lower torso which is useful if tasks require heavy lifting, as shown by the



rehabilitation system developed by ReWalk.

### Helping your workforce

In many ways, exoskeletons are collaborative robots in their truest form. Robots and humans are not just working side-by-side, they are working as one. Not only will this make manufacturers more productive, it will result in fewer injuries, less soreness and less exhaustion.

As well as this, plant workers will benefit from the improved skillset that will come from using an exoskeleton to complete their tasks. Since wearable robotics enable and support workers to do tasks that are otherwise dangerous for a single employee to do, such as lifting extremely heavy machinery, they can complete tasks with more confidence. If exoskeletons can help people walk again then they will certainly offer great benefits to manufacturers looking to optimise the efficiency and capability of their workforce.

If you're thinking about investing in exoskeletons and would like to find out more, visit EU Automation's website [www.euautomation.com/uk/](http://www.euautomation.com/uk/).

EU Automation stocks and sells new, used, refurbished and obsolete industrial automation spares. Its global network of preferred partner warehouses and wholly owned distribution centres, enables it to offer a unique service within the automation industry, spanning the entire globe. It provides worldwide express delivery on all products meaning it can supply any part, to any destination, at very short notice. With several facilities located in key locations across the globe, including the UK, Singapore, Germany and Chicago, EU Automation is primed to get obsolete new or reconditioned automation spares to you in record time. Its teams of customer support staff work together with a global network of partner suppliers, to make sure you get industry leading customer service, especially in critical breakdown situations that can cost millions in lost revenue every year.

**EU Automation**  
**Tel: 01785 303300**  
**Email: [uk@euautomation.com](mailto:uk@euautomation.com)**  
**[www.euautomation.com](http://www.euautomation.com)**

## New human collaborative robot with game-changing industrial performance

A new generation of human collaborative robots which combine important key features and benefits to ensure powerful, robust and safe application capabilities have been introduced by YASKAWA. The YASKAWA Motoman HC20DT robot is the latest example of Yaskawa's expanding range of Motoman Smart Series robotic solutions which are helping users to meet the rapidly changing demands and adaptation of new manufacturing practices.

The Motoman HC20DT is a six axes robot which combines the powerful capabilities of handling payloads up to 20 kg, the flexibility of a reach of up to 1,700 mm with the highest levels of safety. This represents 'game-changing' COBOT potential for applications such as automated palletising which have until now been limited by the payload capacity and working envelopes of other typically available robots. Depending on the application, it can be switched between safe / collaborative mode in phases of man-robot interaction and returning to

high industrial speed when the absence of the operator is detected by additional safety devices.

Operator safety is assured, thanks to features such as power and force limit technology that stops the robot in case of contact with an operator, while the robot arm geometry is designed to avoid finger pinch points. Also, the robot arm can be guided by an operator and robot positions and gripper operation can be registered via 'Teach' and 'Tool' buttons. These features also contribute to time saving during programming and where the application requires additional protective measures, such as safety fences, these can be added in line with risk assessments.

Unlike traditional and more complex robot execution which typically requires significant upfront investment in training, the Smart Series technology provides simple, intuitive programming and operation methods for operators.

Easily adaptable to today's rapidly



changing manufacturing requirements, these robots can be quickly deployed and re-deployed for the next job.

Among the other important features are a fully industrial robot controller, the YRC1000 and YRC1000 micro, safety by design with smooth rounded edges, internal cable routing, a functional safety unit and safe force / torque sensors for all six axes.

**Motoman YASKAWA**

**Tel: 01295 272755**

**Email: jonny.grey@yaskawa.eu.com**

**www.yaskawa.eu.com**

THE FACTORY AUTOMATION COMPANY

**FANUC**

### Ex Demo SPECIAL OFFER\*

ROBODRILL α-D21LiB5

High-performance 5 axis vertical machining centre

**INCLUDES:**

- 24,000 RPM BBT High-Speed Spindle
- Nikken DD200BF Direct Drive 5 Axis Rotary Table
- 5 Axis Simultaneous Machining
- 1,000 Block Look Ahead
- Data Server
- Spindle Probe
- 20 Bar Through Spindle Coolant
- 200l Coolant Tank
- Wash Gun
- Mist Extraction
- Delivery
- Installation
- Training

**NIKKEN**

AVAILABLE WITH  
**TWO YEARS  
WARRENTY**

INCLUDES A  
**£5K SPINDLE  
TOOLING PACKAGE**

£171,834  
**REDUCED TO  
£125,945**



\* P193ZH391  
one ex-demo machine available



# Automating machine tending will be key to cost-effective component re-shoring in the UK

The recent COVID-19 pandemic has been something of a trigger point, highlighting the negative impact that a crisis such as this can have on an extended supply chain. As a result, there are a number of businesses across a wide range of sectors, actively now considering the potential to re-shore the manufacture of components that are currently produced in lower cost economies.

While re-shoring is to be welcomed, UK manufacturers will also have to address the issues which led to parts being manufactured outside of the UK in the first place. Cost, of course, will have been the main driver in many instances and if UK businesses are serious about not just re-shoring, but also retaining manufacture in the UK, then they will need to embrace higher levels of automation to ensure productivity and profitability.

There is no doubt that some manufacturers will be investing in new machining capacity to enhance or consolidate their production capability and it is in these areas where automation, in the form of gantry robot systems, can be a valuable asset in the quest for cost-effective production methods.

As the UK adapts to a changing world, through a combination of the effects of this ongoing pandemic, compounded by the



uncertainty surrounding the possible impact of Brexit at the beginning of 2021, a strong manufacturing sector will be essential for growth and exports. With the UK already lagging behind in the uptake of automation and robotics, plus a general shortage of labour, both skilled and unskilled, now is the time for the UK to embrace the benefits that automating manufacturing will bring. Re-shoring component manufacture will cover a diverse range of part types and industry sectors and those where machined parts are to be produced will definitely benefit from automation.

Gantry robot systems and machine tools are ideal production partners. Güdel's long standing reputation for quality, reliability and durability are the key criteria which have led to the company's gantry robot technology being the first choice for machine loading applications over many years.

The scalable concept of gantry robot systems means that there are no compromises on working range, accuracy and repeatability or payload, and the small footprint frees up valuable floor space for

the machine tools themselves. In addition, by accessing the machine tools from above, the front of the machine remains a fully accessible and safe area for setup or tool changes or other operations when required.

For those seeking a solution for a single CNC machine, it is possible to fully integrate the gantry robot with the machine tool and using either single or double arms, have a simple and compact system which will allow collection from input conveyors, machine load/unload and placement of finished parts onto an output conveyor.

For applications where there may be multiple machine tools and sequential part processing, several robots can be mounted on a single overhead gantry to transfer parts between machining operations. Installations such as this can often be found in engine and powertrain applications where each part may require a number of individual machining operations.

Another characteristic of the gantry robot is its ability to handle high payloads, at speed and without compromising repeatability. In the example shown here, railway wheels and axles are handled by the

gantry robot before being transferred to machine tools for processing.

These three examples alone illustrate the diverse way in which this technology can be configured to suit each particular application.

UK manufacturers seeking to re-shore component manufacturing, whether its large or small, can rely on the ready availability of proven technology to ease their transition to an automated solution.

Having made a decision to bring manufacturing back to the UK, the ability to get into production quickly will be an important consideration and this in turn will require a fast turnaround on the part of any suppliers involved in the project.

To assist in reducing timescales for either end users or system integrators, Güdel UK offers an enhanced scope of supply, in addition to the gantry robot. Güdel's Will Bourn explains: "There is always pressure in any project to deliver the solution as efficiently as possible and we are able to work alongside any other project partners, integrators, or the end user, to deliver a more comprehensive scope of supply. This not only makes it possible for different aspects of the project to progress

simultaneously, but also allows us to apply our expertise in parts handling and machine loading to best effect."

The scope of Güdel's contribution to the project can be tailored to suit the specific application and can range from providing just the gantry robot and gripper system, right through to a complete turnkey system incorporating the control system, guards, fixturing and conveyors ready for production. Existing examples of Güdel's engineered gantry robot solutions range from small parts handling to large systems for handling and machining railway wheels, systems which span multiple machine tools for drive component manufacture and single machine stand-alone fully integrated systems.

Güdel UK Ltd is the UK subsidiary of Güdel Group, a global manufacturer of robotic automation products, systems and services. Güdel supplies linear motion modules, robot track motion units, gantry robots and components to OEM's system integrators



and machine builders serving the automotive, aerospace, logistics heavy industrial and power generation industries. Güdel Lineaertec UK Ltd is based in Coventry, at the heart of the UK's manufacturing base and provides a comprehensive range of services including: design, engineering, system build, customer support and service.

**Güdel (UK) Ltd**  
**Tel: 024 76 695 444**  
**Email: [william.bourn@uk.gudel.com](mailto:william.bourn@uk.gudel.com)**  
**[www.gudel.com](http://www.gudel.com)**

## DUGARD

### Up to 36% Off Market-Leading Kitamura Machines

We're the sole UK and Ireland supplier for Kitamura's world-leading CNC machine tools - and as part of our bid to support the UK's critical industries, we're now offering exclusive deals on some of our most sought-after machines for a limited time.

### The World's Fastest Rapid Feed Rates for 36% Less

#### Kitamura HX250iG

with 10 pallet pool + 102ATC **Was £300,052 Now £190,000**

Never before has there been a machine that packs so much production, precision and machining flexibility into such a compact footprint.



#### SPECIFICATIONS:

TABLE SIZE	<b>254 X 254MM</b>
TABLE INDEXING	<b>0.001° (4TH AXIS)</b>
MAXIMUM TABLE LOAD	<b>100KG</b>
MAXIMUM WORKPIECE DIAMETER	<b>Ø350MM</b>
MAXIMUM WORKPIECE HEIGHT	<b>400MM</b>

#### KEY FEATURES:

- Drastically reduces set-up times for small, highly accurate complex parts
- Amazingly small footprint saves on valuable floor space
- Ultra high speed rapid feed rates of 60m/min
- Powerful 15,000rpm, dual contact spindle. Optional 30,000rpm HSK-E40 spindle available
- Positioning accuracy 2 microns full stroke, repeatability 1 micron
- High power, high-speed processing Arumatik-Mi CNC with 67 million pulse coder technology

Call our sales team now on 01273 732286 or email us at  
 Or visit our brand new website for more information

@ [sales@dugard.com](mailto:sales@dugard.com)  
 🌐 [www.dugard.com](http://www.dugard.com)





## Cobot vs Robot: Which is right for you?

The coronavirus outbreak has raised the profile of automation and how it can lend a helping hand to component manufacturers struggling to cope with the impact and effects of the pandemic.

While some manufacturers may be waiting for the lockdown to be lifted before they fully explore automation's potential in their workplaces, others have 'bitten the bullet' and are actively investigating how automation and, specifically, robotics can help them remain productive and profitable now and in the future.

Prior to making any investment in robotics, manufacturers need to make some fundamental decisions. One of the most important being the type of robotic system that's right for them.

In this article Peter McCullough, product manager for Doosan Robotics, explains the differences between Industrial and Collaborative robot technology for those manufacturers preparing to take the plunge.

In the post-pandemic world, manufacturers across all industries and sectors will no doubt be exploring the potential of automation and robotics and whether they are an investment worth considering. If and when they do, they'll be faced, early on, with an important question: What type of robot is right for my operation and application? Most component manufacturers will have external partners and suppliers, as well as in-house resources, who can help guide or even spec the system but, even if that's the case, it's a good idea to have a baseline understanding of the technologies and terms involved to help navigate the waters and ask to right questions.

The first decision is a fundamental one: Industrial vs. Collaborative robots?

Industrial robots are what most people imagine when envisioning a robot on the shop floor; a big, heavy robot, caged off toiling away welding car chassis after car chassis, twenty-four hours a day with no worker in sight. These 'industrial' robots complete dull, dangerous and repetitive tasks quickly and more accurately than workers ever could.

Collaborative robots or cobots are a more recent development where robots work alongside humans rather than replacing them. Cobots, like their industrial counterparts, are designed to perform

receptive, monotonous or error-prone tasks, freeing-up time for an operator to devote to more complex, creative and value-adding tasks.

It is estimated that by 2025, cobots will comprise 34 percent of total robot sales and these estimates were provided before the coronavirus outbreak. Much of this growth is anticipated to occur from those SME companies who, operating in High-Mix/Low-Volume (HMLV) production environments, realise the flexibility and productivity-boosting potential of collaborative robot technology.

For SME's, understanding the strengths and limitations of both robot types is critical to chart a successful future. Choosing the wrong type can restrict future growth and be expensive; choosing the right

course can ensure more efficient production processes and reduce costs immediately and long into the future.

One of the main advantages of industrial robotics is the speed they can perform complex tasks and the payloads they can handle. As industrial robots are often integrated into more specialised manufacturing systems than cobots, they can deliver significant productivity gains.

However, because of the speed and force provided by industrial robots, substantial safety systems are required to ensure that safety is maintained. The integration of such powerful systems and the safeguards required come with a higher price tag than cobots.

Although cobots operate at lower speeds and payloads than industrial robots their relative low cost, inherent safety and flexibility, easy integration and operation and 'collaborative' nature means, application dependent of course, that they can deliver significant productivity improvements and a fast return on investment.

The innovation in the cobot sector, not just from system manufacturers, but also from accessory, software and end-of-arm tooling suppliers has widened their appeal and application potential.

The capability and acceptance of cobots is clearly increasing and as countries emerge from coronavirus lockdowns and work restrictions, it is likely that adoption and use of the technology will grow exponentially.

**Mills CNC Ltd**

**Tel: 01926 736736**

**Email: [sales@millsncnc.co.uk](mailto:sales@millsncnc.co.uk)**

**[www.millsncnc.co.uk](http://www.millsncnc.co.uk)**





## FANUC introduces hollow arm variance for most popular industrial robot

FANUC has improved upon its popular R-2000 series with the introduction of the hollow-armed R-2000iD.

Capable of integrating cables into its hollow structure, the R-2000iD is ideal for applications that require process cables, such as spot welding or material handling applications. This reduces maintenance costs by minimising the physical strain on the cables and preventing interference with system equipment.

Although the cables are entirely incorporated into the hollow arm and wrist, a number of strategic openings ensure easy access. This means cables can be replaced or maintained individually through wider openings along the arm itself, while an optional bracket flange allows compatibility even without a hollow hand design.

Andy Armstrong, sales and marketing manager at FANUC UK, comments: "By putting the cables inside the robot, it minimises the chance of wear and tear from external forces. It also makes off-line

simulations far easier and more precise, as testing the way that each cable will behave in any given situation is extremely challenging.

"As the robot rotates along its six axes, cables can bend in all sorts of unexpected ways. Having them stored away inside the arm, without the risk of snagging or tearing, vastly increases the reliability of the simulation model."

The R-2000iD comes in two models: the R-2000iD/165FH, which has a maximum load capacity of 165 kg and the R-2000iD/210FH, with a maximum load capacity of 210 kg. Both have a reach of 2,605 mm, with similar dimensions to its predecessor. Crucially, however, the overall footprint is significantly smaller, taking up only 678 x 536 mm.

Andy Armstrong concludes: "Floor space in a production facility is one of the most important factors in the specification of any manufacturing equipment, as it is often at a premium. Positioning the cables inside the



R-2000iD contributes to a more succinct, ergonomic robot, which is able to operate in tight workspaces without sacrificing on payload or reach.

"The R-2000iD has a unique combination of characteristics that mark it out as ideal for process-cable dependant applications. It matches performance with a space-saving footprint and reduced maintenance costs, to ensure that the total cost of ownership is one of the most competitive on the market."

**FANUC UK Ltd**  
**Tel: 024 76 053000**  
**Email: info@fanuc.co.uk**  
**www.fanuc.eu/uk/en/**

**EROWA®**  
 system solutions



# Increase profitability



[www.remsystems.co.uk](http://www.remsystems.co.uk)

### Tooling systems

With highest accuracy and stability



### PreSetting & Quality control

With a high level of mechanical precision



### Robotic systems

For small and large workpieces up to 500kg



### Job-Management software

For easy control of complex automation cells

# Cost-effective and process-secure drilling system

The KOMET KUB Centron is a tried-and-tested drilling tool that has been available for many years, providing cost-effective and process-secure drilling in hole depths from 4xD to 9xD. Previously, KUB Centron drills were only available to order as semi-standard tools, but in a move to make them more widely available the drills are now in-line with the majority of tools from the Ceratizit Group with ex-stock delivery now standard across the range.

Suitable for rotating, stationary and vertical or horizontal applications, the KUB Centron covers diameters ranging from 20 to 81 mm and up to 9xD, making it ideal for drilling transverse holes in housings or holes in cylinder blocks and forged parts. The drill's modular design enhances its cost-effectiveness, with the tool comprising a holder, drill head, indexable inserts and centring drill tip. The drill head is located on the holder by means of a custom-fit centring pin and the head is held in place by two tapered screws acting in the torque direction, which pull it onto the drive dogs. This combination ensures a precise and stable connection. Completing the assembly are adjustable carbide guide pads

for added stability when drilling and exiting the hole, thereby counteracting deflection.

For drills up to 65 mm diameter just two indexable inserts are used. Above that diameter this increases to four, supported in pairs in cartridges. Key to the success of KUB Centron is the eponymous centring tip, which is available in solid carbide or HSS with a TiAlN or TiN coating. This tip guides the tool exactly in the drill axis ensuring dimensional stability, straightness and maximum process security, even with a maximum hole depth of 9xD. The optimised runout properties of the complete system make a long service life possible for the drill point and indexable inserts.

"While the Kub Centron system has been available for some time and has proved its effectiveness across many applications, the strength of the Ceratizit Group can now make that drilling efficiency more widely available. By ensuring that tools, such as Kub Centron are available ex-stock for next day, before noon delivery our customers can rely on Ceratizit to maintain their production by delivering tools when they are needed," says Tony Pennington, managing director of Ceratizit UK & Ireland.

### Improved milling performance on Ni-based alloys

The advantages of nickel-based alloys is that they are able to withstand high thermal and mechanical loads, while being extremely corrosion-resistant, making them suitable for many applications, often under arduous conditions. These advantages, however, present challenges to those needing to machine these 'super-alloys'. Fortunately, Ceratizit has developed MonsterMill NCR, a solid carbide end mill that is more than a match for these materials.

Whether used in the aerospace, chemical, or energy sectors; components made from Ni-based alloys often push machinists and cutting tools to their limits. In order to maintain product quality and productivity, therefore, the use of tools that have been specially designed for this application is imperative. In developing MonsterMill NCR, Ceratizit has eliminated the unpredictability out of working with these materials, making the difficulties associated with machining Inconel and similar materials a thing of the past. The geometry of MonsterMill NCR is precisely tailored to machining Ni-based alloys in order to generate a stable and

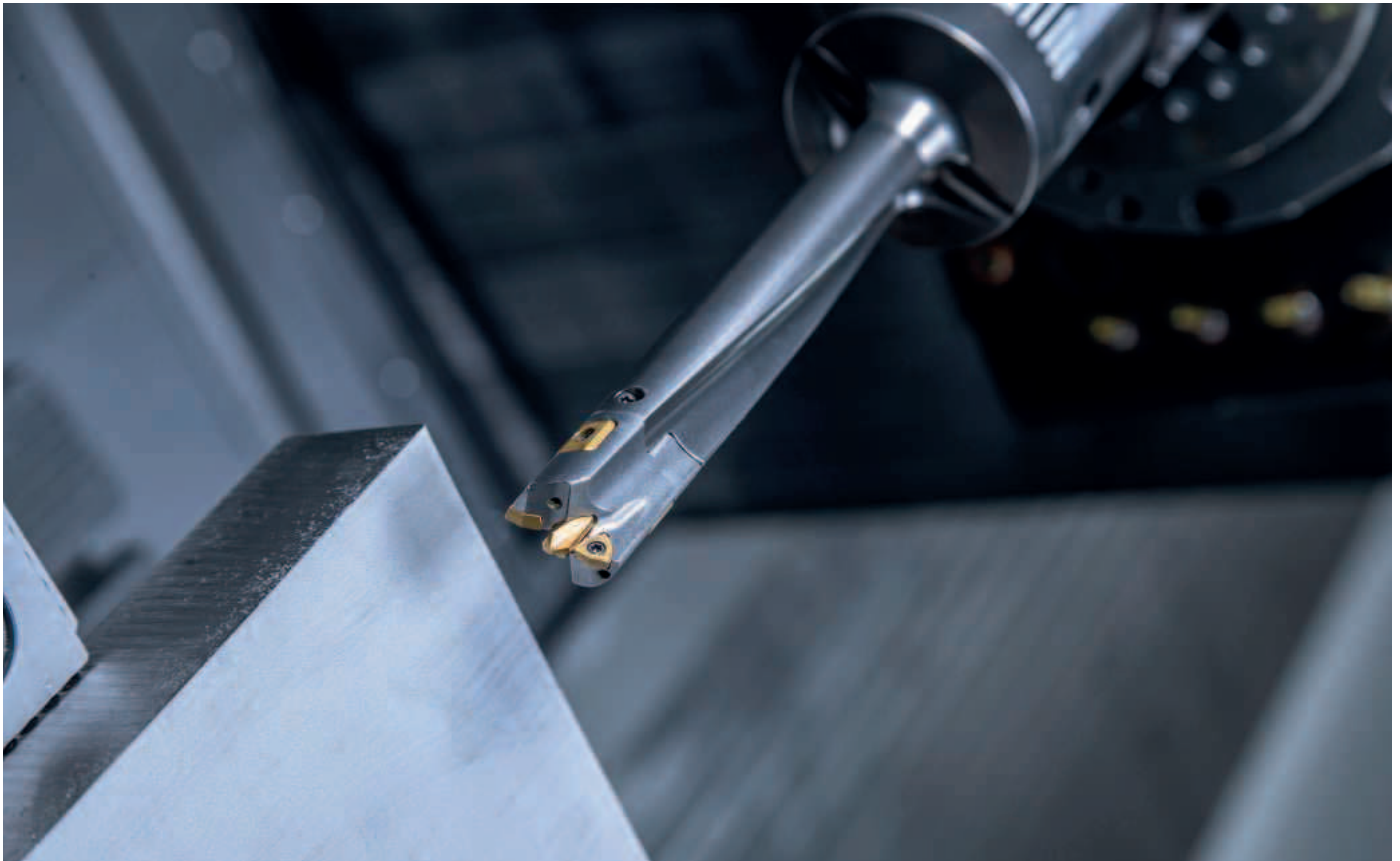

reliable cutting process. This is aided by the reinforced core diameter and increasing taper of the cutter core, which assists in effectively counteracting tool wear in order to achieve impressive tool life. The final piece of the jigsaw was the application of the innovative Dragonskin coating to greatly improve MonsterMill NCR's ability to resist the abrasive nature of these super-alloys, while also providing excellent heat stability, thereby process security.

In cutting tests, MonsterMill NCR achieved a tool life equivalent on machining 13.2 m in length when cutting NiCr19Fe18Nb5Mg material. This is almost 35 percent more than its closest competitor. "These super alloy materials are becoming increasingly common across many engineering sectors here in the UK, therefore having the MonsterMill NCR in our catalogue will be a significant advantage to any of our customers that are faced with the challenge of machining these materials," says Tony Pennington.

MonsterMill NCR is available from stock, with next day delivery before noon for any order placed up to 6:30 pm the previous day. The cutters are available in a range of



diameters from 4 mm to 20 mm, along with a wide choice of corner radii from 0.1 mm to 6.3 mm to suit a wide range of applications, specifically in the aerospace sector. More details can be found online at <https://cuttingtools.ceratizit.com/gb/en/ncr> or by requesting a copy of the latest Up2Date supplementary catalogue.

**CERATIZIT UK & IRELAND Ltd**

**Tel : 0800 073 2073**

**Email: [tony.pennington@ceratizit.com](mailto:tony.pennington@ceratizit.com)**

**[www.ceratizit.com](http://www.ceratizit.com)**

## Hoffmann Group UK aims to double in size with customer-centric reorganisation

Hoffmann Group UK, a leading system partner for quality tools, workstations and Personal Protective Equipment (PPE), has transformed its national strategy to better serve its customers.

To provide its customer base with a more bespoke, effective service, the business is bolstering the number of experts available to advise and consult with clients.

Specifically, the business is increasing technical expertise, introducing dedicated support for large national accounts and additional specialised resource to support services such as inventory management, calibration and repairs.

The reorganisation also sees Peter Borrowdale, who joined the business last year, being appointed as national sales manager. Hoffmann Group UK is also actively recruiting for field and office-based roles, creating a number of additional jobs over the coming months, which will increase the UK headcount by around 10 percent.

As a result of the reorganisation, the company also has plans in place to double

the size of the business by 2023, through more effectively delivering a broad range of services designed to help customers reduce costs and increase productivity. This will be achieved by increasing focus on key product offerings such as PPE, tool vending solutions and workshop tools, as well as increasing its product range and customer base.

As part of this pivot, the business also launched a remote consultation service to support manufacturers keeping the UK running during the COVID-19 epidemic, meaning that it is now able to provide specialist customer support remotely. With the aid of these technologies, manufacturers can bring an experienced consultant directly into their existing workspaces to make bespoke recommendations in areas such as material types and machining optimisation, reducing costs and driving greater levels of efficiency on the factory floor.

Tim Paddison, managing director at Hoffmann Group UK, concludes: "We're now approaching a year of operating in the UK and, despite unprecedented sector



challenges, this reorganisation places us in a fantastic position to achieve our growth aspirations. Our goal now moves towards planning for the long-haul and further establishing the Hoffmann Group in the UK, with a greater focus on the needs of our customers across the nation.

"We're now in a fantastic place to push on and build for the future, helping our customers reduce costs and drive efficiencies to increase productivity."

**Hoffmann Group UK**

**Tel: 0121 7164301**

**Email: [ab.uk@hoffmann-group.com](mailto:ab.uk@hoffmann-group.com)**

**[www.hoffmann-group.com](http://www.hoffmann-group.com)**



## Floyd publishes latest cutting tool catalogue

Floyd Automatic Tooling has now published the latest edition of its 2020 Applitec product catalogue. The new publication is packed with high-performance Swiss manufactured tooling lines suitable for CNC turning centres and sliding head-turning centre users that are manufacturing high-quality precision parts that demand the utmost in productivity and performance.

The 650-page catalogue is crammed with both popular existing product lines and, of course, the very latest in next-generation tooling solutions that will deliver for the challenges of today's modern machine shop. With dozens of pages of new product lines, Applitec has enhanced its TOP-Line turning program with the latest laser-generated chip breaking ZXT Inserts. TOP-Line is still the biggest selling line in the Applitec program, proving that quality pays.

The Applitec TOP-Line Series now introduces a huge variety of new innovations in the latest edition of the catalogue, but of particular interest to precision turning shops will be the ZXT laser-generated chip breakers for grooving and turning operations. With honed edges, laser-generated chip breakers and a complete range of insert geometries and coatings, all available in left and right-hand designations, the ZXT Series will drastically improve precision, performance and swarf control when machining small intricate components.

For cost-effective machining solutions, the new Applitec catalogue from Floyd Automatic highlights the new additions to the PRO-line twin screw and ECO-line single screw insert tool programs. The PRO-Line incorporates a patented and ingenious clamping system with serrated teeth on both the insert and the toolholder. This guarantees rigidity and performance benefits that exceed alternate turning lines. However, it's not just the rigidity and



performance that sets the PRO-Line apart. The serrated tooth design guarantees clamping precision and positioning, giving the end-user repeatability that significantly improves user experience, setup times and tool changeovers. With an unparalleled range of geometries, toolholders, dimensions and coatings, this popular cost-effective range has just got even better.

Another exciting new addition to the new catalogue is the enhanced MODU-Line platens that are now available for most sliding turning centres. The new MODU-Line platens offer increased tool capacity, high-pressure coolant facility, compatibility with most insert tool programs and the ultimate in rigidity, credit to Applitec's patented offset clamping system. The MODU-Line can also be pre-set to fixed or adjustable lengths for fast and precise tool replacement and

changeovers. With adaptors and coolant fittings for all leading sliding head-turning machine brands, the MODU-Line is perfect for any sliding head machine shop.

Other highlights in the new catalogue include the new additions to the ECO-Line of parting, grooving, front and back turning and threading tools as well as the enhancements to the ever-popular EVOCUT Line. The EVOCUT Line from Applitec is one of the most diverse and capable turning solutions for compact work envelopes with Monobloc top clamping tool holders and also the H-Jet range with integrated coolant supply. With an unfathomably diverse range of grades, holders, geometries, insert styles and grades, the EVOCUT Line is perfect for small turning centres and sliding head machines that incorporate platen tool configurations in compact work envelopes.

**Floyd Automatic Tooling Ltd**  
**Tel: 01462 491919**  
**Email: [info@floydautomatic.co.uk](mailto:info@floydautomatic.co.uk)**  
**[www.floydautomatic.co.uk](http://www.floydautomatic.co.uk)**



### Drilling In XXL-Format

With the KUB Centron you can create large holes  
High length-diameter ratio with safety and economy.

For more information:  
[cutting.tools/en/kub-centron](http://cutting.tools/en/kub-centron)

# ITC adopts environmentally friendly packaging

As part of its commitment to the environment, sustainability and social responsibility, Industrial Tooling Corporation (ITC) has now changed all of the packaging on its UK manufactured cutting tools to 100 percent recyclable materials. The Tamworth headquartered cutting tool manufacturer has always demonstrated best practice in both its manufacturing operation and its environmental impact; making this move to recyclable materials is just the latest step in a continuous drive to reduce the company's carbon footprint.

ITC manufactures hundreds of thousands of cutting tools annually using the most technologically advanced and carbon neutral solutions available and while the performance of its cutting tools are reducing spindle load, cycle times and improving machine utilisation to provide cost and environmental benefits to its customers; the issue of plastic recycling and disposal has been problematic to address. That was until ITC's longstanding packaging partner, rose plastic developed its new range of BlockPack and TwistPack Plus Tubes produced from environmentally friendly bioplastic.

rose plastic is a leading manufacturer of packaging for the cutting tool industry and the Rotherham company is delighted to announce that ITC has become the very first UK cutting tool manufacturer to embrace the environmentally friendly packaging.

The new biopolymer plastic is produced using ethanol from sugarcane as opposed to conventional polyethylene, maintaining 97 percent of the chemical properties of conventional HDPE. This ensures that the packaging retains its performance and appearance characteristics while offering 100 percent recyclability and sustainability. The new Bio-HDPE packaging has 96 percent bio-based content that is manufactured from sugar cane. Commenting upon ITC moving to fully recyclable material, Jo Buck from rose plastic UK Ltd says: "rose plastic is fully committed to its environmental responsibilities and the new Bio-HDPE packaging we are manufacturing has environmental benefits throughout the supply chain. This includes a 14 percent reduction on materials used in the BlockPack range, huge absorption of CO<sub>2</sub> throughout the production process and even the Sugar Cane Bagasse residue from production is recycled to replace conventional energy sources."

"This is our most environmentally friendly packaging yet, and we are delighted to now have a completely new range of sustainable Bio-HDPE packaging solutions available for 2020. We have a longstanding relationship with ITC and with both parties being conscious of our environmental responsibilities, this packaging is a huge move forward. ITC is an industry leader in its sector and being the first adopter of this new Bio-HDPE packaging, highlights how the company strives to innovate in all aspects of its business."

ITC's marketing manager, Georgia Graves concludes: "As a business, we have long been committed to reducing our carbon footprint. In recent years, ITC has instigated a range of measures to significantly reduce our oil and fluid consumption, we have introduced new machine tools and technologies that have reduced our power consumption drastically and our recycling programme is extremely comprehensive. We are committed to our social and environmental responsibilities and having a long-term supplier like rose plastic develop this new packaging is another step forward in our journey to becoming carbon neutral."

The Bio-HDPE packaging we have adopted from rose plastic



meets all of our rigorous quality, aesthetics and performance needs whilst further enhancing our environmental objectives."

**rose plastic UK Ltd Tel: 01709 724983**

**Email: [info@rose-plastic.co.uk](mailto:info@rose-plastic.co.uk) [www.rose-plastic.co.uk](http://www.rose-plastic.co.uk)**

SystemBoard

## Everything in perfect order



rose  plastic®  
innovations in plastic packaging

rose plastic UK Ltd. Phone +44 1709 7217 94 · [info@rose-plastic.co.uk](mailto:info@rose-plastic.co.uk) · [www.rose-plastic.co.uk](http://www.rose-plastic.co.uk)

# A gripping tale of workholding innovation

Following many years of providing market leading LANG 5-axis workholding and automation systems through a UK agent, LANG Technik UK has been established to provide both existing LANG users and new customers with first-class levels of sales and application support. The company's highly experienced sales engineers are now available to discuss all potential customers' needs.

Given the prevailing economic conditions, never has the need for users of machine tools to increase their levels of productivity been more urgent. The application of first-class workholding has been proven to deliver the required efficiencies. Superior workholding not only holds workpieces securely and minimises scrap and rework levels, it slashes non-productive time spent on setups and also maximises machine tools' available production time. Rather than being perceived as an added cost, following the adoption of LANG Technik workholding, customers report that, the considerable efficiency and production gains they achieve result in rapid returns on their investments.

Based on the company's close cooperation with its global customer base involved in many challenging industrial sectors, over several decades, LANG Technik's prolific R&D department has designed a wide range of ground-breaking workholding solutions. Now, the company is the first choice for milling operations workholding systems throughout the world.

LANG Technik offers cost-effective workholding solutions that solve all 5-axis machining tasks. In addition to its comprehensive range of innovative clamping devices, the company provides an advanced stamping technology. The highly flexible and modular zero-point system. Also, given the growing trend for unmanned machining operations, it offers cutting-edge automation solutions.

Complementing its already wide-ranging workholding range, LANG Technik recently launched four new workholding systems.

Due to its class-leading workholding capabilities LANG stamping technology remains the benchmark for the efficient processing of raw parts in 5-axis machining. The recently launched advanced Makro•4Grip Clamping System enables a range of completely new applications for the renowned stamping technology.

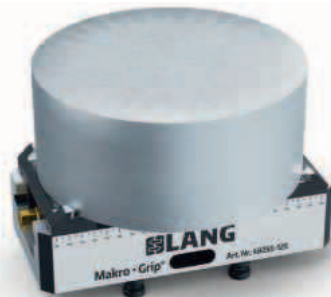

By retrofitting the Makro•Grip stamping unit and LANG centring vices the form-closure clamping technology can be applied to round parts. The advanced Makro•4Grip system uses universal stamping jaws with stamping inserts for individual positioning, in addition it has matching clamping jaws for all sizes of LANG centring vices. The clamping jaws are available as a separate set of jaws for all 77 and 125 vices. The jaws grip the pre-stamped part in four indentations at a clamping height of just 3 mm and provide the same form-closure clamping principle as for the well-proven system for prismatic parts.

Also new to the LANG Technik range and designed for the clamping of round parts is the versatile Vasto•Clamp. The robust 6-Jaw Vasto•Clamp Chuck uses a dependable friction based clamping principle for the secure clamping of round material. With its six top jaws Vasto•Clamp can be used for clamping raw parts with two different hardened gripping jaws or with soft jaws for components that are sensitive to deformation.

The flexible, manually actuated scroll chuck can be used as a 2-, 3- or 6- jaw chuck. Due to its innovative click mechanism the rapid mounting and exchange of the system's jaws is performed without the need for tools. The Vasto•Clamp chuck is available with integrated zero-point studs for the Quick•Point 96 zero-point clamping system.

The perfect solution when working with small diameters that require accurate machining operations, the new LANG Technik Preci•Point collet chuck uses standard ER50 collets which range from 6-34 mmØ clamping. The system features a robust case-hardened construction and has integrated 52 mm Quick Point studs that can be inserted and removed to users existing Quick Point setup with ease.

Preci•Point collet chucks have M6 tapped holes in their base making it easy for customers to insert an end-stop which can be easily removed if through bores are required. The new collet chuck has an extremely thin design allowing maximum accessibility for milling round parts.

Last but not least, a new, cost-effective version of LANG Technik's top-selling Makro-Grip 5-axis vice has just been released. At up to 45 percent cheaper than the company's most popular 5-axis vice, the new Makro-Grip Night King vice represents excellent value-for-money.

**LANG Technik**  
**Tel: 01296 796 576**  
**Email: [gareth@lang-technik.co.uk](mailto:gareth@lang-technik.co.uk)**  
**[www.lang-technik.co.uk](http://www.lang-technik.co.uk)**



# Knockout performance?

The answer's  
**YES**



## Kitagawa

**NC rotary tables**

From 1st MTA, the UK's leading machining  
accessories supplier.

Email: [enquiries@1mta.com](mailto:enquiries@1mta.com) Freephone: 0800 783 0510

Fax: 0800 783 0517 [www.1mta.com](http://www.1mta.com)



## Leader indexing chuck technology helps turn a profit

For both accuracy and efficiency, the philosophy of not letting go once you have located a part is the ideal workholding choice. Nowhere is this better demonstrated than by the indexing chuck, which is more than a chuck; it is a complete technology. Supporting this technology, workholding specialist Leader Chuck Systems offers a wide range of two jaw self-centring indexing chucks in diameters from 125 mm up to 500 mm. Specifically designed for holding valve bodies and similar fittings, the chucks feature interchangeable indexing plates. Usual divisions are four 90° movements with an indexing accuracy of  $\pm 2$  seconds of arc, but divisions of any incremental angle can be specified.

"It is not a new concept," states managing director Mark Jones, "but indexing chucks offer significant advantages for difficult to hold components that would require multiple or staged fixing that could introduce errors. Historically, they have been popular in the production of volume automotive and valve industries for components such as trunnions, couplings and universal joint spiders, valve bodies and multi way connectors. Component accuracy is derived from the indexing accuracy of the chuck as all the machining is effectively related to the first datum setting."

Over the years, the range of components making use of the indexing chuck has become increasingly diverse, as designers and production engineers become aware of the benefits and flats or dimples for location and clamping are being included in the cast or forged raw component material. These features simplify location and can even reduce the size of the chuck required in many instances.

Manually indexed, the chucks which can be manually or power clamped, also support the drive towards lean manufacturing as the ability to fixture a part once helps improve profit margins on shorter batch runs. Even though these chucks provide a complete solution for a specific application, they do so without compromising the flexibility of the lathe. The quick-change philosophy promoted by Leader throughout its workholding product range has also been adopted here and a fully manual chuck can be removed from a typical turning centre in under 10 minutes. The cost of the

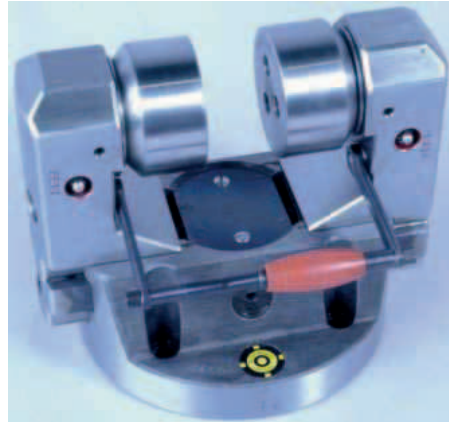

investment is also not prohibitive with manual indexing chucks starting at £5,000. So, there is no penalty for investing and installing a bespoke solution.

Produced from high tensile forged steel a standard range of Leader indexing chucks is available. However, a depth of workholding knowledge and experience will positively benefit the manufacturing process. This is where Leader can help the customer make significant efficiency gains. As Mark Jones points out: "There are a number of prime considerations for selecting the correct size of chuck and it is impossible to select the chuck without considering the tooling required and the access it needs to complete the machining necessary."

Clamping jaws are configured for specific applications and for competitors' products the chucks usually feature one clamping and one static jaw that also provides the indexing drive. This configuration does not provide any self-centring. However, Leader indexing chucks with manual or power clamping offer simultaneous clamping drive that centres the workpiece as accurately as a standard power jaw chuck of the same size, making this workholding system the number one choice for cast raw material machining.

Based in the heartland of British precision engineering, the company now ranks among the world's top suppliers of chucks, workholding, workpiece & tool clamping and raw material/component feeding products. This is offered alongside expert advice and a commitment to customer service that is second to none. A wide variety of component clamping, toolholding and automation solutions makes Leader Chuck Systems a leader in the market.

The company began manufacturing workholding products over 65 years ago. Today, it has an established and acknowledged reputation throughout the international machine tool and precision engineering industries for delivering cost-effective, innovative solutions

**Leader Chuck Systems Ltd**  
**Tel: 01827 700000**  
**Email: [mjones@leaderchuck.com](mailto:mjones@leaderchuck.com)**  
**[www.leaderchuck.com](http://www.leaderchuck.com)**



**WE GENERATE  
EXCITEMENT.**



## **“Keep them at zero, men!”**

Conversion times can be cut up to 90% – with zero-point clamping systems from AMF. This raises machine operating times considerably. So, let's go!

Also ask us about our automation solutions.

UK Sales Office, Tony Fornsworth  
Phone: 0 79 76 94 24 21, [fornsworth@amf.de](mailto:fornsworth@amf.de)



Request your free  
catalogue today!

**ANDREAS MAIER GmbH & Co. KG**  
Fellbach (Germany), [www.amf.de](http://www.amf.de)



## Industry 4.0 pressworking

First shown last November at the Blechexpo 2019 exhibition in Stuttgart, a new Industry 4.0-ready system for automatically positioning and securing a tool on the ram of a power press and then feeding back production data has been launched in Britain and Ireland by Roemheld UK.

Flexline offers numerous configuration options for rapidly installing almost any tool on a variety of punching and forming presses. During operation, integrated sensors measure die or punch holding force and monitor it in real-time, allowing data to be transmitted continuously via an interface such as an IO-link to the press control. As an option, Roemheld supplies evaluation software that graphically displays the condition of tool clamping.

Andreas Reich, head of quick die clamping technology at Hilma- Roemheld in Germany, says: "Many press operators like the fact that their systems can be digitalised and networked with little effort. Flexline is suitable for either factory installation or

retrofitting. It is simple to operate and inexpensive to purchase, so is a practicable, innovative solution that is readily accessible to manufacturers."

Industry 4.0-ready clamps secure the upper punch or die on the ram of an automatic hydraulic press. The operator then has access to information concerning the actual holding force on the tool and is immediately able to detect unusual clamping and stripping forces during production, as well as tool overload, wear and breakage.

A continuous log of the retaining force simplifies error analysis and enables rapid problem-solving when servicing is required. It facilitates predictive maintenance, helping to stabilise a process and avoid downtime. An additional sensor system helps to determine the degree of contamination of the hydraulic working medium, enabling preventive maintenance to avoid failure of the clamping elements. Remote maintenance is also possible.

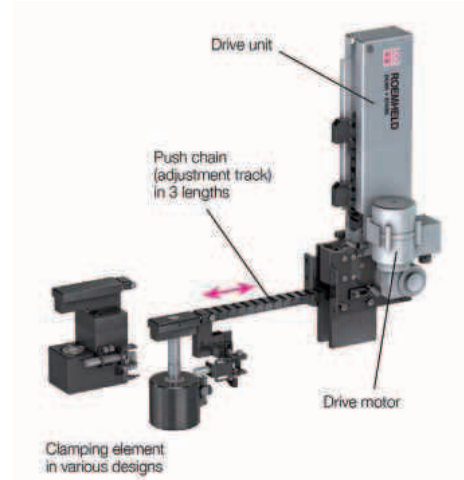

Flexline Industry 4.0-ready has a modular design for mounting on the clamping edge or in the T-slot of the ram. With its double piston, a clamping stroke of 19 mm and a travel speed of up to 150 mm/s, it is suitable for many applications.

**Roemheld UK Ltd**  
**Tel: 01462 459052**  
**Email: Terry@Roemheld.co.uk**  
**www.roemheld.co.uk**

## Kurt Workholding revamps 5-axis vice lineup

Kurt Workholding has announced the launch of its new Precision Force 5-Axis MaxLock™ vice lineup featuring three new models with three available jaw options. Robot-ready Kurt PF-series vices offer new user-friendly features including easy-to-adjust lash and 52 mm spacing for automation-ready mounting systems to adapt to competitors' zero-point systems.

The new quick centreline adjustment makes centreline adjustment fast and efficient and keeps parts perfectly positioned. New spring-loaded gibs keep parts square and are designed to maximise part-positioning repeatability through multiple cycles.

Kurt's PF 420, PF 440 and PF 460 vices come with standard 4-inch jaw width and jaw openings ranging from 2.625" to 6.625" making them the perfect vice for any customer's workholding applications. PF-series vices replace the previous Kurt HP models and feature the patented AngLock® design to minimise jaw lift and deflection. The proven AngLock design naturally pushes the vice jaws down and forward

allowing much greater surface contact on parts, maximising holding strength with less clamp force.

"We wanted to bring a family of 5-axis vices to market that holds parts securely, keeps parts square with excellent repeatability and that are reliable and affordable," says Steve Kane, Kurt Workholding sales and marketing manager. "We are confident that the PF-series vices will address our customers' workholding requirements and reduce operational costs."

Available in three jaw configurations, with either carvable, dovetail or serrated jaws, customers can save the added expense of buying a jaw set they don't need with a PF-series vice. All jaw sets are also sold complete and separately. Kurt PF-Series vices are available now.

Founded in 1946 in Minneapolis, Minnesota, USA, Kurt helps businesses succeed through best-quality contract machining, aluminum die casting, screw



machining and custom product solutions. Kurt's unparalleled engineering expertise and legacy of excellence come together to produce best-in-class products. 100 percent employee-owned and operating over 500,000 sq ft of manufacturing facilities, Kurt is a bright beacon in manufacturing. With over 500 non-unionised workers, it is well positioned to be a leading employer for years to come.

**Kurt Manufacturing**  
**Tel: 001 877 226 7823**  
**Email: skane@kurt.com**  
**www.kurtworkholding.com**

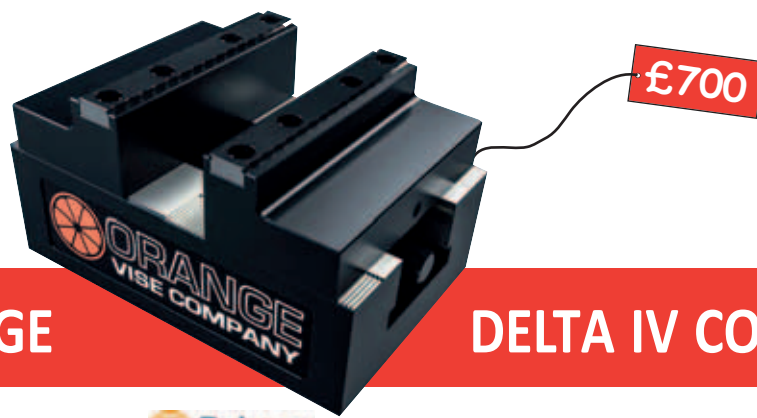

WIN THIS ORANGE

DELTA IV COMPACT VICE!



SPOT THE DIFFERENCE!



Email your answer to: [competition102@leaderchuck.com](mailto:competition102@leaderchuck.com)

OR scan the QR code

Winner will be picked at random after 31/10/20



# When to specify stainless steel for component parts

Stainless steel is a material often specified for engineering projects due to its combination of strength and corrosion resistance. However, there are various grades of stainless steel to choose from, each with their own characteristic and costs, so it's important to make the right choice for your application.

John Marshall, technical manager at WDS Components Parts Ltd, explains the advantages of stainless steel for standard and component parts:

It's the chromium alloy which gives stainless steel its best-known advantage, high resistance to corrosion. The chrome component not only creates the corrosion resistant chromium oxide protective layer, but also contributes to its hardness, making it highly robust and resistant to impact. However, its relative hardness makes it more difficult to machine than mild steel, which means careful selection over your supplier is required in order to ensure optimum product quality and accuracy.

### The main types of stainless steel for component parts

Type 304 is the most common type of stainless steel for component parts, composed of up to 20 percent chromium, enhancing its resistance to corrosion. It's often used in areas which are mildly corrosive, or which require only an occasional washdown, for example handles or hinges. For this reason, it's also a more economical choice. Type 303 has similar properties but slightly improved machinability when very low tolerances are required, but with slightly lower durability.

The highest quality stainless steel generally used for standard parts and components is Type 316. It's added molybdenum component makes it highly resistant to corrosion as well as pitting, the effects of which would create a less hygienic environment and accelerate corrosion. Known as 'food grade', though it's also the first choice in the marine industry, 316 can endure regular chemical washdown or environments of high salinity. While Types 303/4 steels should only be specified for certain conditions, Type 316 could be widely used for any application. These characteristics make it more expensive, although the cost difference between 304 and 316 has reduced over time.

### Growing range of stainless-steel components

The range of stainless-steel components which WDS provides continues to grow through increasing demand across wider industries and applications. Hand knobs, for example, are ubiquitous throughout industry, including food and beverage, marine, and also for machine parts. New to

the WDS range includes a T Knob with threaded stem as well as a four-spoke threaded hand knob, both in 316 stainless steel. While stainless steel is often selected for its shine, the new threaded hand knob is also available in 316 with a matt finish, usually chosen in order to hide fingerprints and maintain the most hygienic appearance.

Another new addition in stainless steel is the handwheel. Handwheels are often provided in aluminium, which can be suitable even for outdoor use if safety, hygiene or regulations allow. However, the new 316 stainless steel handwheel will last far longer and is the choice for use in corrosive environments, such as marine applications. Small crafts to superyachts use WDS components and not only does 316 stainless steel provide the anti-corrosivity required, its aesthetic appeal is also more popular in the market.

Used as a fixing on a machine when indexing a range of motion or series of positions, a cam action indexing plunger is now available in stainless steel. Indexing plungers and bolts are generally manufactured in Type 304, giving adequate resilience even if it's not required to face the full rigours of a daily wash down.

Similarly, castor wheels for use in food manufacture and preparation must meet the necessary hygiene standards, but at the same time aren't required to withstand full washdown. Therefore, a stainless steel Type 304 frame is suitable, combined with a nylon wheel. On the same principle, levelling feet with up to 50 degrees of angle tilt are also available in a 304 stainless steel stem and can be fitted with an anti-microbial polypropylene base.

**WDS Component Parts Ltd**  
**Tel: 0113 2909852**  
**Email: SGray@wdsLtd.co.uk**  
**www.wdsLtd.co.uk**





# The small alternative to a large centric clamping vice

Maximum flexibility for machining a wide range of parts and small quantities is not just wishful thinking; with the Hainbuch modular system it becomes reality. No matter what shape or size, round, cubic, small or large, with the modular system you can clamp any kind of workpiece. The various adaptation clamping devices can be changed over very quickly. The Marbach, Germany-based manufacturer of clamping devices is constantly adding to its modular system so that users can always find the optimum solution for every clamping situation. However, one thing was still missing, an adaptation for clamping cubic parts, which is why Hainbuch has introduced the 2-jaw module to the market.

## The modular system: designed for maximum flexibility

Round workpieces are clamped externally with classic clamping heads, but when these reach their limits, because a larger diameter of the workpiece needs to be clamped, then the 3-jaw module is used. For cubic parts,

the 2-jaw module is used for centric clamping in machining centres and milling machines. In just two minutes, it is possible to change-over from external clamping to centric clamping. The 2-jaw module can even be used at speeds of up to 1,500 rpm. Due to its small, lightweight design it is the perfect alternative to a large and heavy centric clamping device. The basic unit into which the jaw module is inserted is a Hainbuch chuck or vice. Modules can be exchanged without changing the clamping device and, thanks to the integrated Centrex quick-change interface, no alignment is needed.

## Small, light and multitasking

The Hainbuch solution with its chucks or vices and jaw modules is nothing like the gigantic, heavy vices found in many shop floors and whose size is more a drawback than an advantage. In practice this often leads to a large chuck holding a small workpiece. This immediately causes a dilemma because it often means the tools

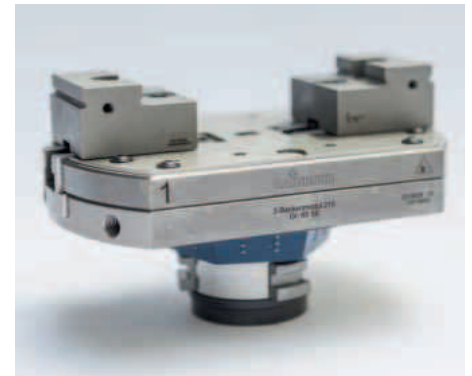

are hard to access. It is not unusual to use special tools, but this comes with a very high risk of collision. By comparison, the Hainbuch modular system is far more efficient and just as capable of multitasking as machine tools are nowadays.



**Hainbuch UK**

**Tel: 01543 278731**

**Email: [nick.peter@hainbuch.co.uk](mailto:nick.peter@hainbuch.co.uk)**

**[www.hainbuch.com](http://www.hainbuch.com)**

**MicroLoc**  
Advanced Referencing Workholding Systems  
Production • Automotive • Aerospace • Sub-Con

 Designed and Manufactured in the UK by Micron Workholding  
 MicroLoc is a registered trademark of Micron Workholding Ltd
 

- The all **NEW** hydraulic system reduces operator fatigue
- Increases productivity
- All the benefits of the manual MicroLoc System



**Secure clamping on just 2mm**

Helping you hold onto your **PROFIT!!**



Visit us at MACH: Stand 19-20

**Micron Workholding Ltd**

SALES 01480 861321  
[www.microloc.com](http://www.microloc.com)  
[sales@microloc.com](mailto:sales@microloc.com)

## Pneumatic, fail-safe swing clamps

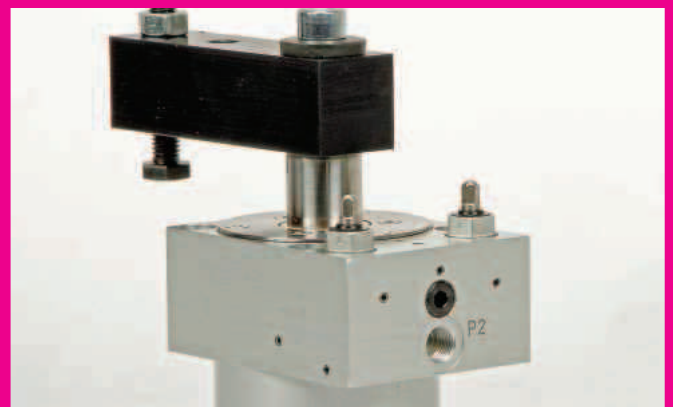

### Securely clamp parts for machining

- Mechanical lock maintains full holding force up to 600N
- Even if air is disconnected - ideal for APC
- Speed of swing mechanism adjustable
- Enables synchronisation or sequencing



**ROEMHELD**  
 HILMA ■ STARK

Find out more at  
[www.roemheld.co.uk](http://www.roemheld.co.uk)  
 or call 01462 459052

**Roemheld workholding.** Driving Innovation through Manufacturing

## Ready for the smart factory

### TRUMPF presents new TruPrint 2000 3D printer for medical devices

TRUMPF has announced a new 3D printer, TruPrint 2000, that lends itself to medical engineering and other applications with lofty standards and quality. TRUMPF experts revamped the system so inert gas now flows through it back to front. This enhances printed parts' quality. In another new development, the operator can now remove excess powder from the component right there in the system rather than having to take it out and unpack it at a separate station, as in the past. This is easier and saves time when dealing with the smaller build chambers of 3D printers such as the TruPrint 2000. The newly designed machine now processes the printing powder in an inert gas environment, which prevents contaminants from infiltrating the powder circuit. This is a key advantage for sensitive medical devices etc.

"With the TruPrint 2000, we are showing that TRUMPF puts the needs of AM-focused industries first; that is, the aerospace, automotive, mechanical engineering, tool and mould making and the medical and dental engineering industries. The TruPrint 2000 enables manufacturers to take advantages of additive manufacturing's benefits, particularly medical and dental engineering companies," says Klaus Parey, managing director of TRUMPF Additive Manufacturing.

### Highest productivity at low cost

The TruPrint 2000 features the Multilaser design. Two 300W lasers working in tandem illuminate the 3D printer's entire build chamber to boost the system's productivity. Taking the same approach as for the TruPrint 1000, TRUMPF development engineers reduced the TruPrint 2000 laser's focal diameter to 55 µm to print components with smoother surfaces, enhanced quality and intricate grid structures. The TruPrint 2000 is perfectly at home printing parts out of titanium, a material that figures prominently in medical devices. Companies do not need a separate unpacking station, so they also save money with this printer.

"The machine's new design brings the benefits of lean manufacturing to users. It requires fewer add-ons, so the entry-level investment is lower for companies that want to get into AM," says Florian Krist, product



manager at TRUMPF Additive Manufacturing.

### Digital monitoring built in

Users enjoy the benefits of automated powder bed and melt pool quality monitoring. In the event of an error, the system notifies the operator, who can then take remedial action. Another great benefit is an end-to-end documentation trail that corroborates the quality of the printing process. This is a key prerequisite for the additive manufacturing of medical devices.

### Getting implants to patients that much faster

TRUMPF has already used the new machine to print interbody cages, which are implanted to add stability to the spine. These can be inserted as a placeholder between two vertebrae to restore the vertebral segment's natural height. The lasers' small focal diameter lends itself to fabricating the implants' intricate structures. Healthy bone tissue adheres well to these structures. It takes this new system just 24 hours to produce 19 spinal implants. It not only serves medical engineering companies well; it is also an excellent choice for dental applications and tool and mould making.

With 300W of laser power, it has no trouble handling standard materials such as cobalt-chromium alloys. With that kind of performance, it can readily fabricate dental casts as well as injection-molded parts with complex internal cooling channels.

They provide a more precise way of controlling the temperature of tools during production, which makes them more durable and improves cast parts' machining quality. This also slashes cycle time for printed tools and boosts productivity.

### 3D printing opens up new applications for amorphous metals in industry

TRUMPF has joined forces with Heraeus AMLOY to work together on the 3D printing of amorphous metals, also known as metallic glasses. The goal is to establish the printing of amorphous parts as a standard production method on the shop floor by improving process and cost efficiencies. Amorphous metals are twice as strong as steel, yet significantly lighter and more elastic. They exhibit isotropic behaviour, which means their material properties remain identical, regardless of the direction in which the 3D printer builds up the workpiece.

In addition to creating highly robust parts, 3D printing also gives engineers more freedom in the design process. A number of areas could benefit from 3D printing of amorphous metals. Key examples include parts that are subject to significant stresses and lightweight design in sectors such as aerospace and mechanical engineering. These materials are also an excellent choice for medical devices due to their biocompatibility.

"3D printing of amorphous components in industry is still in its infancy. This new

collaboration will help us speed up printing processes and improve surface quality, ultimately cutting costs for customers. This will make the technology more suitable for a wider range of applications, some of which will be completely new," says Jürgen Wachter, head of the Heraeus AMLOY business unit.

"Amorphous metals hold potential for numerous industries. For example, they can be used in medical devices, one of the most important industries for additive manufacturing. That's why we believe this collaboration is such a great opportunity to make even more inroads into this key market with our industrial 3D printing systems," says Klaus Parey, managing director TRUMPF Additive Manufacturing.

Amorphous metals are formed by cooling molten metal extremely quickly. A 3D printer can then build them into larger, more complex parts; something that other methods are unable to do. This opens the door to new industrial applications for amorphous metals. 3D printing also exploits the considerable potential that amorphous metals hold for lightweight design. A 3D printer only builds structures that actually help a part fulfil its function, so material use and weight are kept to a minimum. For their part, amorphous metals are very light by nature, so the combination of 3D printing and amorphous metals can reduce weight in all sorts of applications. 3D printing makes the production of amorphous parts faster and simpler in a wide range of contexts. The technology enables users to build parts in one piece instead of making components one by one and then assembling them into a finished part.

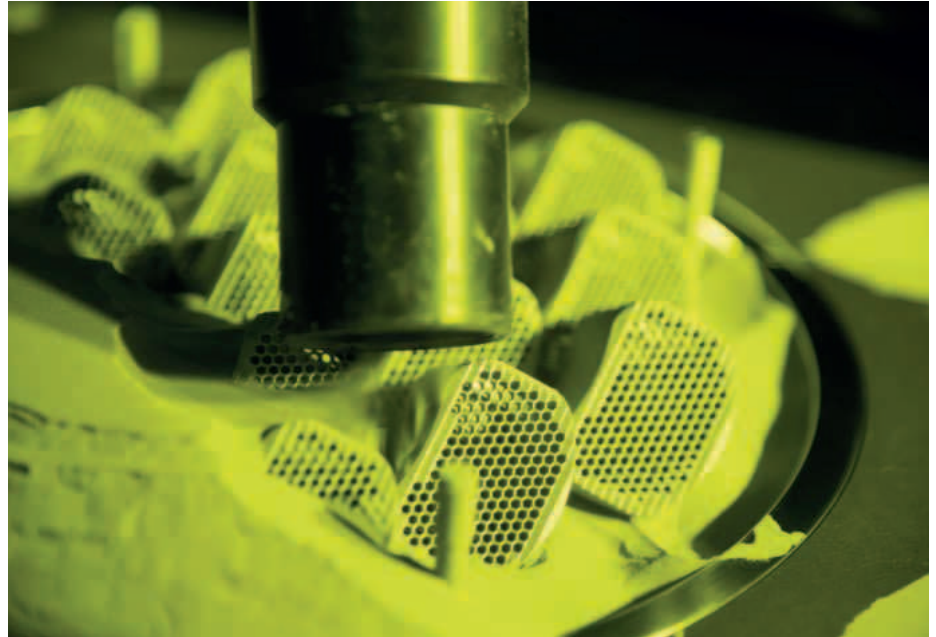

In this cooperation, Heraeus AMLOY combines its expertise in the production and processing of amorphous metals with TRUMPF's experience in additive manufacturing. Heraeus AMLOY has optimised its amorphous alloys for 3D printing and tailored the material for use with TRUMPF's TruPrint systems. The latest-generation TruPrint 2000 machine is a particularly good choice for printing amorphous metals. The machine is designed in such a way that the excess powder can be prepared in an inert gas environment for the subsequent building process. This protects the powder from any adverse influences. This is a key benefit for amorphous metals



because they react so quickly with oxygen.

TRUMPF has also boosted the productivity of the TruPrint 2000. Two 300W lasers scan the machine's entire build chamber in parallel. Using a laser focal diameter of just 55 micrometres, users can carry out both low and high-volume production of amorphous parts with extremely high surface quality. The "Melt Pool Monitoring" function automatically monitors the quality of the melt pool, so any errors in the process are spotted at an early stage.

Customers that already have a TRUMPF 3D printer can now use it to process zirconium-based alloys from Heraeus AMLOY. It is also possible to order 3D-printed amorphous parts directly from Heraeus AMLOY. The two partners are also hoping to make copper- and titanium-based alloys available for 3D printing in the future.



**TRUMPF Ltd**  
**Tel: 01582 725335**  
**Email: sales@uk.trumpf.com**  
**www.uk.trumpf.com**



## Ultrasonic technology enhances manufacturing processes within Russia's automotive industry

For technical solutions to be optimised and operate most effectively, it is essential that both the technology manufacturer and the end user work together closely and communicate clearly and concisely. This is especially true for ultrasonics, where the greatest benefits will be realised when the ultrasonic specialist and customer work together at the early stages of the project to incorporate design features which will aid production processes.

Ultrasonic technology is becoming increasingly recognised as both a reliable and cost-effective process, for joining and cutting lightweight automotive components. The introduction of ultrasonic technology has transformed a number of manufacturing processes within the Russian automotive sector including: assembly operations on door panels or spoilers and mounting sensor brackets on thin-walled bumpers.

One example of the technology in action is on the front bumpers for the Škoda Karoq and Škoda Rapid models, which are manufactured using Telsonic's ultrasonic welding and cutting equipment, supplied by Windeq TC Telsonic's Russian partner headquartered near Moscow. The company is the first Russian system manufacturer to design and produce semi-automatic ultrasonic systems for the automotive manufacturer and Windeq TC has also been recognised as an official supplier to Magna Russia since 2019.

Other applications where ultrasonic technology is a key process include the manufacture of the front and rear spoilers and reflector mounts for the VW 316 Tarek. Lada also use ultrasonic systems to attach the structures used for electric window guides and brackets for interior door panel



Integrating ultrasonic technology within automated manufacturing and production systems is simple. The ultrasonic generators are able to communicate with the control system of the processing machine using a common field bus interface

storage compartments. In this application it was possible to use dual sonotrodes, as these joining processes require welding to take place at particular spots and along seams. This is a distinct advantage in areas where the welding points on the seams are close together. With two blades, a dual sonotrode is able to produce two welds at the same time whilst only requiring one converter and booster to apply mechanical vibrations.

The Telsonic Group, headquartered in Bronschhofen, Switzerland, has been providing ultrasonic technology solutions in Europe, America and Asia since 1966. Continuous innovation helps to ensure that, in many applications, the company

maintains a lead over competitors, offering added value to users. With more than 250 highly-qualified staff the owner-managed family company specialises in plastic and metal welding, together with ultrasonic cleaning, screening and cutting. Current trends mean that these skills are in strong demand, e.g. for lightweight construction, electromobility, battery production, the packaging industry, medical technology and 3D printing.

**Telsonic UK Ltd**  
**Tel: 01202 697 340**  
**Email: info.uk@telsonic.com**  
**www.telsonic.com**

# PSL DATATRACK

Flexible Production Control software  
for subcontract precision engineers

Est.  
**1988**



engsub@psldatatrack.com    twitter.com/psldatatrack    www.psldatatrack.com    08456 345931

## DP Technology announces support for additive DED manufacturing

For centuries, manufacturing industry has relied on subtractive machining. But over the last two decades, additive manufacturing, commonly known as 3D printing, has become a more widely used manufacturing process.

As one of the main additive manufacturing processes, Directed Energy Deposition (DED) uses a focused energy source, such as a laser or electron beam, to melt the material. The ability to control the grain structure of a part makes DED a good solution for the repair of functional metal parts. For example, DED is often applied to rebuild large, expensive and high-wear components for aerospace, energy, or marine industries, such as turbine blades, drill heads, or propellers. DED is also one of the few metal 3D printing technologies suitable for integration into CNC machines to create a hybrid manufacturing solution. By mounting a deposition nozzle on a multi-axis machining system, highly complex metal parts can be produced faster and with increased flexibility.

To satisfy this growing market demand, DP Technology is working closely with some

of the world's leading machine manufacturers to validate their brand-new additive cycles.

The DP Technology teams are proud to announce the very first commercial version of ESPRIT that includes additive DED cycles. ESPRIT's additive capabilities are the product of the team's more than 35 years of experience in toolpath generations and they include the same intuitive user interface that users expect from the software. The product release includes 3-axis, 4-axis, and 5-axis DED support. Combined with the subtractive processes and embedded into a single software, DP Technology brings a full spectrum of support to hybrid manufacturing.

ESPRIT's additive DED cycles include additive simulation and verification, as well as global support from ESPRIT's technical teams.

DP Technology validated its post processor through collaboration with major machine manufacturers and educational institutions. "For more than a decade, we've been working on Additive Manufacturing (AM), including research on DED toolpath

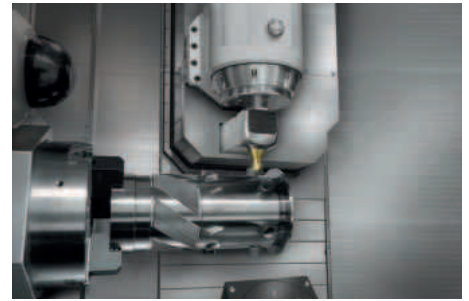

trajectories and AM thermal simulation. ESPRIT's additive DED solution is the result of the close collaboration between DP Technology, the industry's most trusted CAM solution provider and Grenoble University, the world's leading research institution on additive DED technology," says Frederic Vignat, head of the Additive Department at Grenoble University in France.

**ESPRIT CAM Ltd**  
**Tel: 0151 6323415**  
**Email: [chris.edwards@dptechnology.com](mailto:chris.edwards@dptechnology.com)**  
**[www.espritcam.eu](http://www.espritcam.eu)**

## Sequential Scheduler enhancements for improved accuracy and reporting

As part of the production planning process for subcontract precision engineering companies, PSL Datatrack's Sequential Scheduler module is designed to assist in the scheduling of shop floor processes and is subject to continual improvements. The module helps to create a closely controlled, smooth flow of work throughout a factory so that deliveries are made on time and any potential bottlenecks which may result in late delivery are identified, allowing rescheduling to take place.

One key purpose of using the Sequential Scheduler is to provide an overview of the sequence of jobs that need to be undertaken to manufacture any component on any shop floor resource, inclusive of any subcontract operations that may be needed. PSL Datatrack has constantly added new levels of functionality to the module to improve its accuracy, functionality, reporting abilities and real time shop floor visibility. These have historically been

achieved through closer integration with the quotations module, enhancements to the Shop Floor Data Collection (SFDC) module and the use of the status board display system to provide real time visibility on the progress being made on any job throughout each operation.

The latest development in the software helps to increase efficiency by allowing operations that have similar setup requirements to be grouped together. Time can then be saved on setups and overall manufacturing efficiency improved. Furthermore, any grouped operations can either be brought forward or delayed until an economic quantity of components under manufacture is available or before being sent out for plating or any other third-party finishing processes that may be needed.

This new functionality helps ensure jobs are correctly prioritised and required materials are readily available. The reporting



features provide management with a quick view of the time required to complete jobs and allow any replanning or rescheduling to be calculated within seconds.

Prospec Systems Limited is a leading author and supplier of PSL Datatrack production control software. The company was established in 1988 and its friendly, experienced team has supplied solutions to manufacturing businesses for over 30 years.

**PSL Datatrack**  
**Tel: 08456 345931**  
**Email: [sales@psldatatrack.com](mailto:sales@psldatatrack.com)**  
**[www.psldatatrack.com](http://www.psldatatrack.com)**



# Aberlink CMM breathes life into NPI quality

The current global COVID-19 pandemic has caused a monumental shift in manufacturing, both in the way parts are produced but also the processes to produce them. As more companies turn their focus to the medical industry, quality assurance has taken on an increased level of importance. One such manufacturing company involved in this radical challenge is NPI Solutions Ltd.

Established in 2001, NPI is a subcontract machining company specialising in the precision engineering and manufacture of products for diverse sectors including defence, medical and power generation to the more niche, high-end audio market.

The Irvine, Ayrshire-based company has the capacity to fulfil every customer demand, boasting not only a wide range of 4- and 5-axis mills and turning centres, but also modern, fully equipped sheet metal, anodising and powder coating departments; the whole manufacturing process under one roof. It is this one-stop approach that has found NPI growing dramatically, handling upwards of 400 orders per month equating to over 40,000 components.

However, with the advent of the COVID-19 pandemic, many companies have found themselves dedicating resources to the manufacture of ventilators. Such critical medical equipment is ultimately reliant upon components subject to the most stringent quality control requirements.



NPI operations director, George Gillespie explains: "As a company we invest a lot of money every year in the latest production equipment, we're quite happy to spend £250k on a machine tool because it produces components. We had not made significant investment in quality and inspection for several years, relying on a combination of manually driven Coordinate Measuring Machines (CMMs) and other standard inspection room equipment. The ventilators gave us the nudge required: we had to get a new, more advanced CNC CMM and fast."

"When the ventilator work started coming through at pace, we found ourselves making three of the main critical ventilator body components in very large batches. Machined on three or four faces, the components were intricate and required considerable inspection. We had to be able to check them very accurately and very fast. To have manually checked the required geometry for these components would have been a nightmare."

The main issue facing NPI was that due to the knock-on effect of the pandemic, many CMM manufacturers did not have the ability to demo, supply or install a machine and certainly not in the required timescale.

George Gillespie continues: "We knew of Aberlink and the great reputation that the company has and so, assisted by Tony Smith of Northern Metrology, we quickly placed an order for an Axiom too CNC CMM. In an ideal world, we needed a CMM installed and operational in two weeks. Aberlink really stepped up to the mark in exceptional circumstances and supplied it in just three."

Following the successful installation of the cutting-edge Axiom too CNC CMM, complete with fully motorised probe head, the final piece of the puzzle was training, made more difficult by the need for social distancing.

Aberlink was able to offer NPI a full and extensive remote online training session. However, George Gillespie, being a skilled engineer by trade and faced with increasingly tight deadlines, made the



decision to test the waters himself. He explains: "With the support of two or three phone calls to Aberlink's free technical support, I was up and running with the machine. If you are a good CNC machinist and you know your way around parts, the Aberlink Axiom too CMM is so easy to learn. I am a great believer in just diving right in and the included Aberlink 3D measurement software was so easy to learn, even when working with CAD models. Although not a substitute for dedicated, hands-on training, the support videos and manuals supplied with the machine are more than enough to get you up and going."

Now, with the slowing demand for the ventilator components, NPI plan on making the Axiom too an integral part of their manufacturing and it will be heavily relied upon for the accuracy of all projects, including those for the company's many Tier 1 and Tier 2 customers who demand comprehensive inspection reports.

**Aberlink Ltd**  
**Tel: 01453 884461**  
**Email: sales@aberlink.com**  
**www.aberlink.com**





# Mitutoyo

## Programmability gives digital height gauge the edge

Automatic running of part programs makes the *QM-Height* an outstanding instrument for increasing productivity, decreasing operator fatigue and practically eliminating measurement errors in the inspection room. Fingertip positioning provided by the optional pneumatic suspension makes light work of surface plate work.

Our proprietary Digimatic ABSOLUTE linear encoder delivers high accuracy, resolution and repeatability. Easy one-key, icon-based commands for frequently used measurements, such as inside/outside diameter and pitch calculations, ensures excellent ease-of-use. Go/No-Go tolerance judgements are quickly set up and performed on critical feature dimensions.

Your inspection room measurement begins and ends with us.  
For more information visit: [www.mitutoyo.co.uk](http://www.mitutoyo.co.uk)



# MECH Metrology improves measurement certainty by 50 percent

Bowers Group has supplied MECH Metrology with a Trimos Horizon Premium Length Measuring Machine which has increased capacity for inhouse calibration services and improved certainty of measurement by 50 percent. In addition to enabling the business to calibrate plug gauges traceable to UKAS standards, the Trimos Horizon Premium is used to calibrate a variety of equipment including thread, plug and ring gauges, plain plug gauges and plain ring gauges.

MECH Metrology is now able to test screw ring gauges and internal threads in house, a job that would have been previously subcontracted out. The Trimos Horizon Premium has also improved MECH Metrology's output, as well as significantly increasing the efficiency of the calibration process.

Russell Johnston, owner of MECH Metrology, says: "There are three key reasons why we chose to invest in the Trimos Horizon Premium; capability, capacity and accuracy. We can now calibrate more equipment in house than ever, at an even higher level of accuracy. In fact, I would estimate that the Trimos has improved our certainty of measurement by 50 percent. Speed of process has also improved significantly, so we can get more work done in less time."

Based in Fareham, MECH Metrology and Power Tools Ltd has been in business for over 26 years as a one-stop-shop for metrology equipment and calibration

services. In addition to supplying businesses with quality branded metrology products to meet customers' gauging, tooling, and measurement needs, MECH Metrology also offers a fully traceable calibration and repair service.

"Customers are increasingly looking for a one stop solution which we can offer with confidence" explains Russell Johnston. "Following a request from a customer, we simply take the item off the shelf and send it straight into the lab for calibration before it goes out the door. It's a perfectly streamlined process. Our calibration management system ensures that equipment is recalled for calibration in a timely manner, customers have access to online certification information and all data is electronically held."

The need for quality control is an essential activity in most businesses, so it's important to have effective calibration processes in operation. The ability to perform accurate measurements on a consistent basis can only be achieved if instruments used are periodically calibrated to designated standards. MECH Metrology recognises the importance of being able to offer a cost-effective and comprehensive calibration service to all its clients and have many customers that benefit from calibration management services.

As part of its ongoing investment in people and equipment, MECH Metrology is always looking for ways to improve and refine its services. After the business



received a number of regular calibration requests that had to be subcontracted out, MECH Metrology decided to invest in the equipment that would ensure they could carry out the requests in-house, therefore improving services and calibration turn-around times. Previously using an older generation Trimos THV Mini Horizontal, MECH Metrology decided it was time for an upgrade, which Bowers Group were more than happy to provide.

As a top of the range model designed for workshop or laboratory use, the Trimos Horizon Premium Length Measuring Machine is ideal for the control and calibration of measuring instruments with fixed and variable dimensions. All measuring ranges are direct, which means that the whole measuring range is available without adjustment or intermediary re-calibration. A large selection of interchangeable accessories completes the possible applications and guarantees a correct positioning of the instruments to be calibrated. Not only is the Trimos Horizon Premium robust and well designed, it is simple to use and offers fast and precise checking for optimal and high productivity measuring results.

Craig George, technical sales engineer at MECH Metrology, says: "We were driven to invest in the Trimos Horizon when we couldn't carry out some of the calibration requests we received internally. We didn't want to continue to have to subcontract them out, so the Trimos Horizon has solved this issue for us. It allows us to carry out far more of our calibration services in house, without having to subcontract out the items we didn't have the capacity for."

**Bowers Group**  
**Tel: 01276 469866**  
**Email: [sales@bowersgroup.co.uk](mailto:sales@bowersgroup.co.uk)**  
**[www.bowersgroup.co.uk](http://www.bowersgroup.co.uk)**

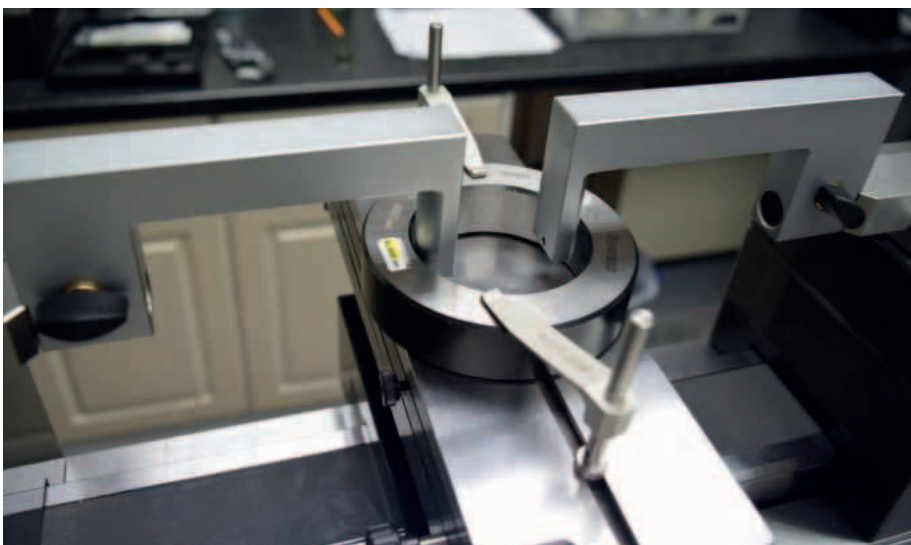



We are **specialists**  
in contract  
measurement services,  
using the **latest**  
**metrology technology**  
and **equipment**.

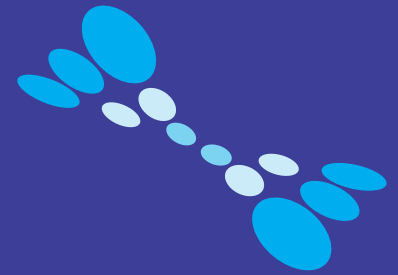

Manchester Metrology



t: 0161 637 8744  
f: 0161 425 0944  
w: [www.manchester-metrology.co.uk](http://www.manchester-metrology.co.uk)  
e: [info@manchester-metrology.co.uk](mailto:info@manchester-metrology.co.uk)



[manchestermetrology](https://www.facebook.com/manchestermetrology)



[manmetrologyLtd](https://twitter.com/manmetrologyLtd)



[manchester-metrology-limited](https://www.linkedin.com/company/manchester-metrology-limited)



[manchestermetrologyLtd](https://www.instagram.com/manchestermetrologyLtd)



# First advanced Mitutoyo CMM in Europe for the ESL Group

Following the hi-profile launch of Mitutoyo's CRYSTA Apex V range of CNC Coordinate Measuring Machines (CMMs), the Basildon, Essex-based ESL Group recently became the first company in Europe to take delivery of one of the advanced CMMs.

Founded in 1962 as a specialist, subcontract gear-cutting business, ESL Engineers Ltd quickly gained an excellent reputation for its technical expertise and for the quality of its output. Impressive levels of organic growth over several decades and strategic company acquisitions, has allowed the progressive company to considerably increase its production capacity and to significantly expand its range of manufacturing specialities.

Having added the ability to produce a diverse range of precision machined components to its renowned gear-cutting proficiencies, the ESL Group has consolidated its numerous activities into an impressive, 30,000 sq ft manufacturing facility and can now be truly regarded as a single-source, precision engineering subcontractor.

Accredited to ISO9001 and AS9100D and boasting many aerospace approvals, the ESL Group has developed partnerships with many leading aerospace companies and has applied its strict aerospace manufacturing and quality standards to other equally demanding sectors.

As a long-time, loyal user of Mitutoyo CMMs, to enable the company's busy quality department to maintain its exacting quality standards and to speed-up its inspection work, the ESL Group recently purchased a newly launched Mitutoyo CRYSTA-Apex V CNC CMM model.

ESL Group quality engineer, Dave Humphrey explains: "The ESL Group have used Mitutoyo CMMs for over 20 years and have been very impressed with their ease and speed of use, also their reliability and accuracy. In addition, we always receive excellent service from Mitutoyo UK."

"As Mitutoyo continually develops its CMM technology, to stay at the forefront of inspection advances, periodically we have replaced our older Mitutoyo CMMs with the latest models. This policy has allowed us to take advantage of the most up-to-date



advancements in CMM technology and has helped us to uphold our meticulous quality standards.

"Recently, the need to further increase our inspection capacity has occurred. Having installed a Mitutoyo Apex S CNC CMM less than two years ago, on contacting Mitutoyo UK it was interesting to hear about the technical improvements made to the brand new Mitutoyo CRYSTA-Apex V CMM range.

"Although we considered that progresses in areas such as software enhancements means that the new CMM represented a further step forward for Mitutoyo, before committing to purchasing an CRYSTA-Apex V machine we followed our normal commercial practice of considering the merits of other CMM brands in terms of their capabilities and price. As previously, the new Mitutoyo CMM proved to be the most attractive option and an order was placed.

"So new is the CRYSTA-Apex V range, we were the first company in Europe to take delivery of the advanced CMM. Our new CRYSTA-Apex V CNC CMM and our existing Mitutoyo CNC CMM are now located in our environmentally temperature-controlled quality department. As the new machine is an evolution of its predecessor, it was easy for our three quality department staff to quickly become accustomed to its operation and already

they are able to swap from machine to machine with ease.

"Our CRYSTA-Apex V and our older Mitutoyo CMM are the mainstays of our quality provision, we use them to perform 1st off, in-process and final inspection routines and a multitude of other high-precision measuring and inspection tasks, such as the generation of full F.A.I and SPC reports. When required we are able to supply these reports to our customers and to archive all traceable inspection data. In addition to inspecting one-off parts, it helps that we can load multiple smaller components onto the CMMs' beds, recall the relevant programs, then perform fully automated CNC, mass inspection routines."

A wide choice of Mitutoyo CMMs are available in a range of sizes and accuracy classes, enabling practically all precision 3D measuring applications to be covered. Drawing on the technological expertise of a world leader in metrology, each Mitutoyo machine represents an excellent investment in terms of productivity, versatility, quality of construction and not least, training and service support.

**Mitutoyo (UK) Ltd**  
**Tel: 01264 353123**  
**Email: philip.fisher@mitutoyo.co.uk**  
**www.mitutoyo.co.uk**

# Manchester Metrology works with Wenzel

The WENZEL exaCT® M is a new powerful and flexible CT scanner, used for measuring and testing small to medium-sized components.

It was built around a workstation-concept and its compact design, with well thought-out ergonomics, make it possible for this new CT scanner to combine more power and flexibility with less space requirements. It has an integrated evaluation unit which allows for easy loading and makes it ideal for automating measuring and testing processes.

The workstation is used for measuring and testing small to medium-sized components, with a measuring volume of 300 mm in height and 200 mm in diameter. It is particularly suitable to use in dimensional metrology and Non-Destructive Testing (NDT) of components, assemblies and materials.

This new CT scanner's flexibility makes it possible to be used in a variety of other fields including: Dimensional control; Wall thickness analysis; Actual-to-nominal comparison; Tool and component

optimisation; Development, Rapid prototyping; Reverse Engineering; Material defect analysis; Structural analyses; Assembly tests; Joining technology testing; Electronics testing.

The WENZEL Group is a leader in innovative metrology. WENZEL's technology is used in all industries, including the automotive sector, aeronautics, power generation and medicine.

WENZEL technology solutions are installed throughout many industries such as automotive, aerospace, power generation and medical. The company has an installed base of more than 10,000 machines worldwide. Subsidiaries and agents in more than 50 countries take care of sales and provide after sales service support to our customers. Today the WENZEL Group employs 650 people worldwide.

Manchester Metrology Ltd is the official re-seller of the WENZEL exaCT M and is a leading metrology company offering



subcontract engineering work and metrology equipment for hire or purchase across the UK and worldwide.

**Manchester Metrology Ltd**  
**Tel: 0161 6378744**  
**Email: info@manchester-metrology.co.uk**  
**www.manchester-metrology.co.uk**



## **BOWERS GROUP**

PARTNERS IN PRECISION

### WHATEVER YOUR **MEASUREMENT NEED...**

*Bowers Group offer a range of dedicated metrology equipment and services to **turn designs into quality components***

**Tel: 08780 50 90 50**  
**Web: www.bowersgroup.co.uk**  
**E-Mail us for more details**  
**sales@bowersgroup.co.uk**

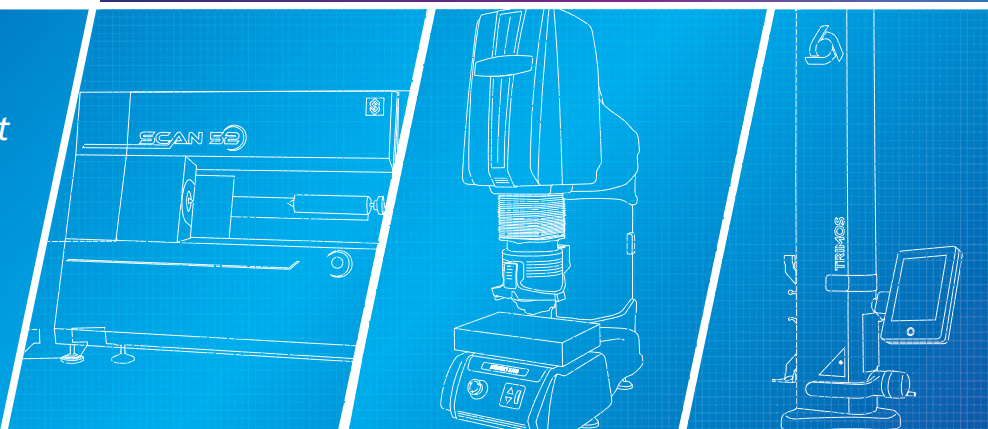

The Bowers Group of Companies

# Tebis CAD/CAM supports Cloud-based advanced tooling library for CAM automation

Paul Scally, operations manager of Tebis UK, explains why you need Tebis cutting tool library for CAM automation

Tebis CAD/CAM software offers a unique Cloud-based cutting tool library to store best practice manufacturing information together with four other database libraries: Virtual Machines with clamping devices; Geometric features associated with machining features, Machining cycles; Machining processes. Tebis cutting tool library not only stores cutting tool geometry shape information, but also stores advanced machining parameters grouped for different materials and different machine tools as well as different toolholders.

The cutting tool library interacts with all the other libraries and can sit on a server in the Cloud for administration and control. What makes Tebis CAD/CAM different from other software systems is the many more types of manufacturing parameters stored with it and the way Tebis deals with and uses the data. The advanced manufacturing parameters are organised in machining groups and include spindle speeds, feed rates, step-down feed rates, and corner feed rates. These stored best practice parameters are useful not only to new users but also to experienced users so as that they do not need to remember the parameters or taking the time to check the cutting tool manuals. Without the advanced cutting tool library, it is quite often that the best practice manufacturing parameters may not always

be used so as that machining quality and efficiency may be compromised.

Tebis cutting tool library is capable of storing the exact geometry of cutting tools, toolholders and intermediate tool holders and validate the assembly. This ensures these elements used by the CAM users are correct and available on the shop floor.

With the Cloud-based environment, Tebis has the master tool library sitting on the Cloud and this is the tool library which is managed by the administrator and the management to ensure consistent uses among all users even across different work shifts and sites. Tebis software automatically downloads the latest library data by activating the system and users always work with the latest data. This is beneficial to large and also small installations.

Another advantage of Tebis CAD/CAM is the support for lens cutters and large radius contour cutters. Tebis uses the exact contour of these cutters for toolpath calculation and is able to accurately simulate residual stocks on the parts when these are used.

When working with Tebis geometry and machining features, cutting tools can be automatically chosen by the software and matching appropriate machining processes.

Tebis software can also mirror and store the tool tables and magazines for a fixed or

random carousel. In this way, cutting tools can be organised into magazines, tool cabinet and special builds. Tebis CAD/CAM allow customers to optimise and standardise cutting tools and machining parameters for materials, machines, machining operations and machine groups to achieve the best machining quality and highest efficacy.

## Tebis CAM automation with feature library

For Tebis, automation is a key principle for effective and efficient CNC programming while improving machining quality, efficiency and safety. One of the features to support CAM automation with Tebis CAD/CAM is the use of the feature library.

Andrew Walters, application engineer for Tebis UK explains why you need Tebis CAM automation with feature library: "The feature library is the way of recognising the geometry data within the CAD model. Once Tebis software recognises the geometry data and assigns some basic attributes then, Tebis can start to add predefined machining operations to machine the geometries in the CAM programming process. This creates an environment where machining operations and parameters of the features can be optimised, standardised, predefined and are consistent across the company's entire working process to improve CAM programming efficiency and quality.

"The feature library within Tebis automatically detects and assigns features to the geometries and automatically group features for machining. In addition to working with ruled geometries, Tebis software also recognises free-form geometries and do feature-based NC programming. Features are not limited to the usual 2.5D type features such as holes and a slots, Tebis software is capable of dealing with 2D open features and free-form shapes."

**Tebis (UK) Ltd**  
**Tel: 02476 158178**  
**Email: info-uk@tebis.com**  
**www.tebis.com**

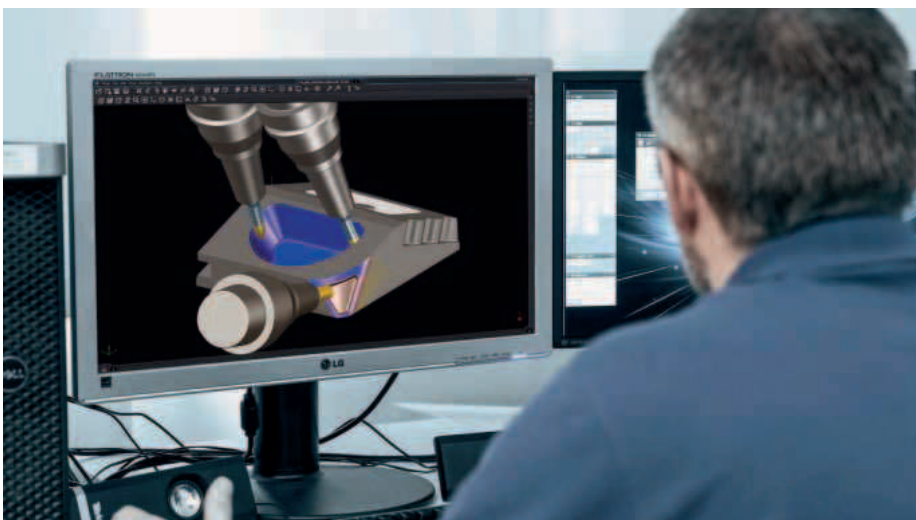



## Hypertherm announces release of ProNest 2021

Hypertherm, manufacturer of industrial cutting systems and software, has announced the release of ProNest<sup>®</sup> 2021, a major version update of its advanced CAD/CAM nesting software for automated cutting. This new release contains new features and enhancements designed to make customers more efficient and profitable.



Redesigned 2D CAD package provides improved font support, ability to shape text and other new features that are especially popular among sign makers. CAD editor preference for users to set a default CAD program for edits to parts in the ProNest part list. Select the embedded ProNest CAD software or choose a third-party software such as AutoCAD. Part report can be quickly opened from the part list so users can add individual part reports with an image of the part, plus dimensions, size, material, class, process, costing information and more. Interior bridge cutting to add bridges to text and other interior geometry so that pieces don't drop when cut. This helps minimise interior cut-outs on parts for aesthetic purposes and reduces tip-ups.

"ProNest 2021 builds on the strong foundation of ProNest 2019 to make the programming process more efficient," says Tom Stillwell, marketing project manager for Hypertherm CAD/CAM software products. Whether using plasma, waterjet, laser, or oxyfuel cutting, this new version provides the powerful tools fabricators and manufacturers need to increase material savings, boost productivity, lower operating costs and improve part quality."

In addition, Hypertherm is releasing upgrades to its ProNest LT software for lighter production environments. Users with an active subscription and customers with an active maintenance plan can upgrade to the new version of their respective product at no additional charge and continue to receive unlimited technical support and other benefits.

Hypertherm designs and manufactures industrial cutting products for use in a variety of industries such as shipbuilding, manufacturing and automotive repair. Its product line includes cutting systems, in addition to CNC motion and height controls, CAM nesting software, robotic software and consumables. thousands of businesses.

**Hypertherm Europe B.V Tel: 0031 165596907**  
**Email: [info@hypertherm.com](mailto:info@hypertherm.com) [www.hypertherm.com](http://www.hypertherm.com)**



### Make Production Smarter

Hexagon offers a range of CNC simulation software, factory automation solutions and computer-aided manufacturing (CAD / CAM) packages specifically for various production methods.

| Visit [hexagonmi.com](http://hexagonmi.com)



# ALPHACAM – a Hook to Leemark’s aerospace success

Target of just two operations for even the most highly complex 5-axis components

A company specialising in manufacturing complex aerospace components helped develop a family of 45 high-spec parts for a helicopter cargo hook in just five months, using ALPHACAM CAD/CAM software.

The Hawk 8000 Cargo Hook has been selected for the next-generation Bell 525 Relentless helicopter, which is currently being developed. Drallim Aerospace were contracted to design the hook which needed to be capable of handling an 8,000 lb payload. They had already worked with Leemark Engineering on a number of products and approached them to manufacture the casings, Solenoid covers, heavy-duty linkages, levers and pins for the assembly.

Leemark is run by three brothers, Mark, Kevin and Neil Stockwell. Set up by their father over 50 years ago, they retain the family ethos of quality and customer service. Principally supplying precision components to Tier 1 aerospace companies, their parts can be found on aircraft such as the Lockheed Martin F35 Lightning fifth-generation stealth plane, the Saab Gripen E fighter jet and various military, police and civilian helicopters, along with ejector seats and satellites.

Most components are highly complex, manufactured on 12 CNC machine tools at



their factory in Middlesex. Leemark director and production manager Neil Stockwell explains that 11 of those machines are programmed with ALPHACAM: “It drives all our 3- and 5-axis Matsuura machining centres, CMZ Y-axis and 2-axis lathes and Agie wire eroder. The only one it doesn’t drive is the spark eroder, which has conversational software.”

He says ALPHACAM was an essential piece of the equation when it came to producing the Hawk 8000 cargo hook components, mainly from aerospace

aluminums and billets of hardened AMS 5643 American spec stainless steels, along with a small amount of plastic.

Neil Stockwell says: “We were tasked with not only manufacturing them from scratch but producing them as if we were making them in large volumes, so we needed tight cycle times. Being aerospace, there were AS9102 reports with every component and it meant that the processes were sealed, so that when they did go into full production there were no more qualification periods to go through.

“We achieved all that within five months, thanks to ALPHACAM’s built-in machining strategies which helped us to optimise our high-end machines and cutting tools.”

Leemark manufactures every machinable part for the Cargo Hook; the most complex, in terms of 5-axis machining, being the cover and solenoid case. However, the most accurate is the steel lever which carries out several actions inside the body of the hook.

“A high percentage of the milled components have bores on them with an 18-micron tolerance,” adds Neil Stockwell. “The majority of the turned components have even tighter tolerances.”

Engineering director Kevin Stockwell says programming time varies from around half an hour for simple parts, to between 15 and 20 hours for the most complex components, with machining cycle times taking up to two

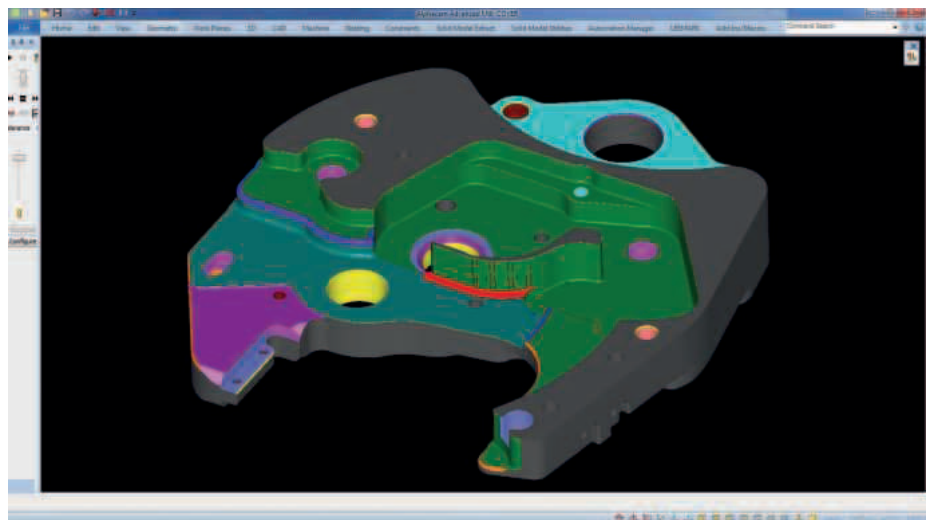

hours: "We use waveform and trochoidal milling strategies which give us significant savings on cycle times and extends tool life."

His programming process begins with importing STEP models, working out the best way of machining the part, and how much excess material they need to hold it during cutting. This is vital to their philosophy of keeping 5-axis machining limited to two operations wherever possible.

Kevin Stockwell continues: "We hold the part on one face to work on all the others. Then a second operation machines the final face. We restrict as many parts as we can to just two setups. Components are becoming increasingly more complicated nowadays as designers try to limit the weight of everything that goes on the aircraft. But ALPHACAM Advanced Mill's 5-axis capability means we're not only able to produce them, but we can keep cycle times and costs down, too."

He works from the imported STEP file without having to create another model inside ALPHACAM, by simply programming on its workplanes, selecting a face and plane and then machining from it.

The company is also heavily involved in the ejector seat business, having recently worked on a short-lead-time project with a number of new, complex components.

ALPHACAM recently showed another side of its versatility to produce a repeat order of parts for the Saab Gripen fighter jet, after ten years. Kevin Stockwell adds: "These were originally programmed on a previous version of ALPHACAM and run through post processors that we no longer use. But by re-engineering them and reprogramming them with our current version of ALPHACAM, we reduced cycle times through fewer operations, keeping the price down in line with what it was ten years ago."

He says that satellite parts are particularly complex, some of them taking around 20 hours to program, but Kevin Stockwell estimates it would take at least 50 hours without ALPHACAM.

Their machines currently run 18 hours a day, but part of their continual improvement plan includes extending their 5,500 sq ft

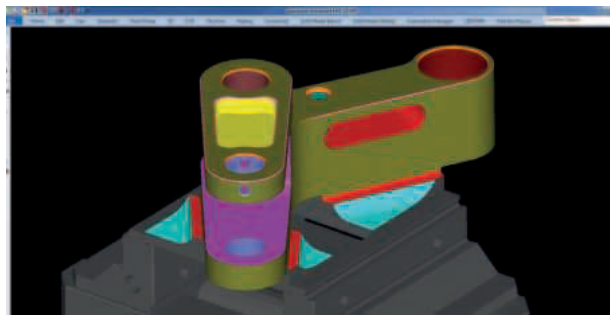

factory by a further 2,000 sq ft to house additional machine tools. Those new machines are likely to include a pallet system powered by ALPHACAM, so they can progress to lights out manufacturing.

Concluding, Neil Stockwell says that having used the software for many years they wondered if they had become complacent about it and did look at other packages on the market: "But we saw that ALPHACAM was still the very best fit for Leemark."

**Hexagon Manufacturing Intelligence**

**Tel: 01242 542040**

**Email: [enquiry.uk@hexagonmetrology.com](mailto:enquiry.uk@hexagonmetrology.com)**

**[www.hexagonmi.com](http://www.hexagonmi.com)**

**Gc GibbsCAM®**

**MULTI-TASK MACHINING**



GibbsCAM delivers many new capabilities to improve and accelerate every part of the programming process, taking parts from concept to creation in record time.



Tech CAD/CAM - GibbsCAM UK distributor since 1997

☎ 01284 754781 🌐 [www.techcadcam.net](http://www.techcadcam.net) ✉ [info@techcadcam.net](mailto:info@techcadcam.net)



# Waterjet cutting turns waste into added value

## Improved material recycling and usage with waterjet cutting

When processing expensive materials, it's important to minimise waste. The following case shows how waterjet technology can produce Inconel cylinders and save material in the process. By using waterjet technology to cut out holes instead of drilling them, the residual material can be stored, shaped and reused. This not only delivers better economy, but new product opportunities.



### The results match the challenge

This case involves cutting holes up to 127 mm, 3 inches, in diameter in 152.4 mm, 5-inch, wide Inconel cylinders. The tolerance requirements are high and, until recently, processing has been performed by drilling. As the circumference of the hole is more than 50 percent of the material's diameter, drilling means a good portion, 36 percent, of the material is turned into waste.

The narrow incisions, 1-1.5 mm and fine kerf of waterjet cutting provides multiple recycling possibilities. Instead of simply drilling a hole, waterjet technology cuts out three separate pieces from the original material, much like stacking a Russian Matryoshka doll. The results are residual materials that can be recycled instead of wasted.

This is a precision process with a high potential for material savings. Success is dependent upon the correct cutting parameters, as well as the machine's performance and precision. The challenge is to attain a result that lies within tolerance requirements, while maintaining accuracy over time.

### A standard solution with a twist

The solution is based on a Water Jet Sweden H-model with a 2 x 1 m, 6.6 x 3.3 ft, table surface. It's a standard machine model, but it offers a complete workstation for all types of high-tolerance waterjet



cutting in 2D. The 152 x 203 mm, 5 x 8 inch, cutting items do not require a large work area. So, despite high-tolerance requirements, this standard machine size is more than adequate. It is adapted to this particular machining process for easy and practical material management. Using a standard model also means that this solution is both cost-effective and proven, ensuring performance over time. The H-model comes with optional, extra-high cutting pressure. A KMT Pro 3 60 HP delivers 6,200 bar of water pressure, resulting in faster processing and straighter cut surfaces, even with thicker materials.



The H-model is a true, high-performance CNC machine. It comes with FANUC OiF CNC control systems and a FANUC 8.5" touch-screen panel with an easy layout, especially designed for waterjet cutting.

### Customised tank and fixtures

In order to cut the thick cylinders with up to 6,200 bar, this H-model solution is enhanced with a customised tank, designed for an effective and smooth production process. The solution also includes extra splash guards on the side and a special nozzle cover to spread water horizontally. When piercing thicker materials this is important for the working environment, as water spray is often deflected. To ensure both high precision and repeatability, the tank is equipped with an integrated fixture system that consists of three parts: a fixture bench, a palette fixture and material holders.

The fixture bench is connected to the tank with special feet for improved support and maximum stability and repeatability. The

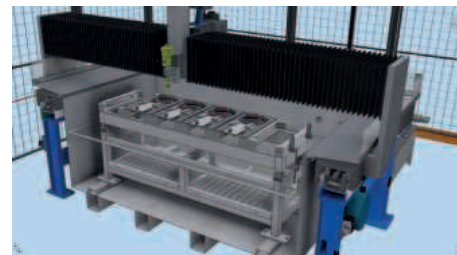

palette fixture is designed to be easily moved in and out of the tank. Special cone-shaped guides automatically realign with the starting position on the fixture bench. The material holders are designed to handle various item diameters and withstand tough manufacturing environments. Easy loading and unloading provides an efficient workflow and manufacturing process.

In order to withstand the continual wear of both water and sand, the customised tank and fixture solution is manufactured entirely in stainless steel.

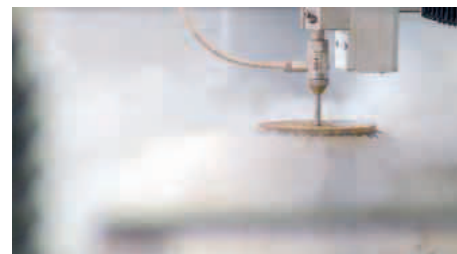

### Added value is standard

"Thanks to the customised tank and special fixture solution, our H-model machine is now an enhanced workstation that performs a highly specific and precision production process," states Tony Rydh, CTO and founder of Water Jet Sweden. "Both the tank and the fixture system are designed for easy operation, and smooth loading and unloading with a specialised forklift. The robust design means durability that can withstand years of cutting in tough manufacturing environments. Finally, it delivers an improved economy and new opportunities for years to come."

**WJS UK Ltd**

**Tel: 01937 845499**

**Email: info@wjsuk.com**

**www.waterjetsweden.co.uk**

# DISCOVER WHAT AN OMAX ABRASIVE WATERJET CAN DO FOR YOU!

**OMAX Waterjets** streamline operations by reducing your need for multiple machines, secondary processes and extensive employee training. OMAX Waterjets are the perfect complement to your shop. The flexible tool cuts like a saw, machines like a lathe, contours like a mill, shapes like a wire EDM, and forms like a broach. Learn more today.

**CUTS STEEL,  
ALUMINIUM, GLASS,  
FOAM, RUBBER,  
CARBIDE, STONE  
AND GRANITE**

**EASY  
FIXTURING**

**USER-FRIENDLY  
SOFTWARE**

OMAX@OMAX.COM • WWW.OMAX.COM

FOLLOW US    

 **OMAX**® ABRASIVE WATERJETS



# Sustainability made profitable

A manufacturing company that wants to keep up in the future will inevitably face the issue of sustainability. For small and medium-sized companies, this is a Herculean task that requires a great deal of planning, foresight and knowledge in parallel to day-to-day business. Costs and benefits must be weighed, standards set, restructuring planned and employees sensitised. Measures which, due to their complexity, are dangerously often postponed or not implemented in a concerted manner. Austrian waterjet pioneer StM Waterjet has now created a solution for this problem with its "Green Philosophy". It offers users holistic manufacturing concepts that are optimised for sustainability and combine profitability with maximum performance and flexibility. It thus opens up the possibility for companies to make production processes more economically viable, while minimising negative effects on the environment and sparing energy and natural resources.

This is made possible by StM's modular waterjet cutting system, which has been continuously optimised in terms of sustainability and adapted to the latest requirements for decades. Interested companies from the steel and stainless steel, aluminium, non-ferrous metal, plastic, stone,

glass and ceramics processing industries can have this system adapted to their individual needs by experienced application engineers at StM and have processes demonstrated live, an input that requires no investment whatsoever. This allows companies to evaluate the effects of new processes without any risk. In the end, they will benefit from a solid and flexible "ready-to-use" solution that is operational 24/7 within a few days and requires little training.

With this partnership-based sustainability policy, StM ensures that the "Industry 4.0" standard does not have to be introduced at the expense of profitability and will not overburden anyone. Further information on the "green philosophy" is available to interested parties at the StM test centres in Germany, Austria and Switzerland.

### More power, less consumption and wear

Waterjet cutting is per se an energy-efficient cold cutting process. At StM Waterjet, this advantage is supported by the design as well. StM waterjet cutting systems are consistently designed as a raw-material and energy efficient system that can be adapted to changing cutting requirements at any time. Their service life is typically 15 years or more. The construction of a StM waterjet cutting system is low-vibration, very robust

and at the same time designed to be lightweight, on average 1,800 kg. This minimises the drive power of the motors and maximises cutting speed and cutting quality. The electronic components are RoHS-compliant standard modules for which the manufacturer guarantees spare part availability for at least 10 years, even after production has been discontinued. The thermally sensitive axis amplifiers are cooled by an energy-efficient, temperature-controlled air conditioning unit. This ensures a long service life of the components.

All lamps and lights as well as sensing devices are designed with LED technology. The electric motors of the high-pressure pump and the system components have efficiency class IE3. These energy-efficient asynchronous three-phase motors save energy during the entire service life of StM waterjet cutting systems. StM also uses electronic speed controls, which further increase performance, where appropriate. The high-pressure pump has an oil/air cooler. Comparable high-pressure pumps of the competitors need 12 litres/minute water to cool the pump. All system components, including the high-pressure pump, switch off automatically after cutting or in the event of a fault in order to avoid unnecessary power consumption. In addition, StM waterjet





cutting systems require only 50 litres/minute of compressed air for the control valves and no sealing air for the guides and drives. Up to 400 litres/minute per cutting head are common on the market.

But waterjet cutting "powered by StM" helps to save resources even beyond the energy aspect. It requires minimal personnel and tool costs. Material consumption is minimised by technical details like infinitely variable abrasive dosing and the efficient nesting of cutting jobs. The StM SmartCut cutting software also enables the cutting of workpieces on raw plates so efficiently and closely nested that 10-20 percent of raw material can be saved compared to conventional cutting processes. Rejects are minimal, especially with sensitive materials, as the tool water cuts without structural changes or thermal stress.

### Minimum storage, maximum recycling

Due to the extreme flexibility of the waterjet cutting process, users can react immediately to current demand and switch to just-in-time production. After all, a wide variety of materials can be cut without the need for retrofitting costs. Parallel pure water and abrasive cutting is possible, regardless of whether 2D, 3D, pipe or robot cutting is requested. This makes expensive warehousing history. StM waterjet systems are additionally made of 90 percent steel and aluminium. These raw materials are 100 percent recyclable. Individual components of old systems can still be used for new acquisitions, as the StM module system is almost fully compatible. Seals and process water can also be reused, e.g. with the fully automatic "StM OneClean" recycling system for water and abrasive. All residues can be separated and disposed of properly.

### Programmed for healthy economic management

StM's "Green philosophy" also has a social component, which aims to make work healthier. This is due partly to the fact that waterjet cutting produces neither gases nor dust and noise pollution is moderate. Furthermore, the operation of a StM system is very convenient. On the other hand, the system takes over the heavy and monotonous work as well as tasks that require great precision. This not only minimises rejects and errors, employees also enjoy working more. With a standard PC and the intelligent SmartCut software from StM, drawings can be imported and cutting parameters defined in no time at all. The system calculates cutting time and costs per order so that production in the ideal cutting area can be controlled at any time. Malfunctions can easily be remedied by the user or through remote maintenance. Maximum safety is ensured by plastic hoods on Z-axes and cable carriers as well as a clearly visible warning light.

On request, StM's application engineers will explain how the StM's "Green philosophy" can be used in the best possible way for your own operation. Interested parties who would like to get an idea of this convincing system and the service concept at StM are invited to inform themselves without obligation at any time by visiting the website or visiting the StM test centres in Austria, Germany and Switzerland. They can, among other things, have test cuts made and employees trained there to become application specialists as part of training courses.

**StM Stein-Moser GmbH**  
**Tel: 0043 6458 20014832**  
**Email: info@stm.at**  
**www.stm.at**

**WARDJet**

Cut materials up to 300mm thick

Cut bevels up to 60°

THE NEW  
**APEX 60**  
 PUTTING 5-AXIS CUTTING WITHIN REACH

wardjet.com/apex60  
 01952 291600

## Factors of speed

It is often asked "how fast is a waterjet?" OMAX waterjets are faster than many cutting machines on the market. Exactly how fast depends on a number of factors. Power, material, thickness and more need to be considered when determining how long a finished piece will take to cut. For example, tool steel will have a different cutting time than titanium. The following are the main factors that affect the speed of OMAX machines:

### Power of the pump

Double the horsepower of the pump and the cutting speed will dramatically increase. Horsepower determines how much water is actually flowing through the waterjet's nozzle. Think of a 30 hp pump as a garden hose and a 100 hp pump as a fire hose. If the goal is to move as much water as possible, efficiently, thereby inducting the abrasive into the stream and cutting, then the fire hose is going to be faster.

### Material

In terms of types of material, an abrasive waterjet is the most versatile cutting method available. OMAX machines are currently being used to cut aluminum, brass, carbon fibre, glass-refined plastics, ballistics laminates and much more. With abrasive waterjets, there is no need for special coatings or other considerations. Materials simply need to be fixtured into place. The cut product has no Heat-Affected Zones (HAZ) or material distortion, often removing the need for secondary machining.

Typically, the harder the material, the

slower the cut. There are some exceptions to this: titanium generally cuts faster than steel on a waterjet. The thickness of the material is also a factor. Waterjets can cut any thickness up to the Z-height of the cutting head, but thicker materials will cut more slowly than thinner. As long as the material in question is lower on the Mohr scale than your cutting medium, you can cut it.

### Geometry of the part

Simple parts are faster to cut than more complex parts, which is true for all industrial cutting methods. However, when you get into more complex shapes, the specifics of the cutting tool can make incremental changes that result in huge time savings. A waterjet is a machine tool that shows its true benefit when cutting complex geometries on a variety of materials. For abrasive waterjets, hardware performance only provides a portion of the potential cutting performance returns. An optimal software controller is capable of ensuring exceptional precision throughout every angle and curve in a cut while increasing the speed of production and reducing the cost of consumables. To get the full value of your abrasive waterjet, you need the best hardware coupled with the best, most optimal software and OMAX's IntelliMAX software is the most advanced waterjet cutting controller on the market.

### Desired surface finish

The higher the quality of a part's surface finish after cutting, the longer it will take to

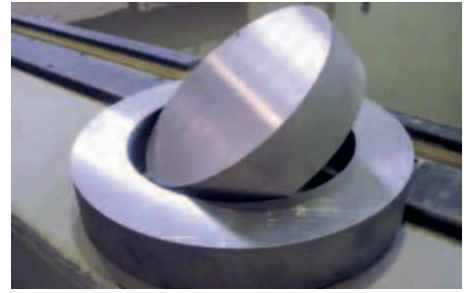

make the piece. Due to its precision and high cut quality, many fabrication shops use their waterjet as a single-stop tool. This means the parts that come off the waterjet are ready for use without any secondary machining.

To save time, several manufacturers aim for lower quality surfaces because they plan to cut near-net shapes. Integrating this near-net shape cutting into processes significantly reduces production time. An abrasive waterjet can handle large sheets of raw material and cut multiple blanks with very little setup and fixturing time. Abrasive waterjets can easily cut material that's difficult to machine on a CNC mill, such as Inconel®, Hastelloy® and titanium, and there's no need to change tooling to cut different types of material.

### Up-to-date software

OMAX is constantly refining its cutting models and implementing new, clever optimisations that speed up production. Take advantage of these by regularly updating your software. Software can make a huge difference, especially when

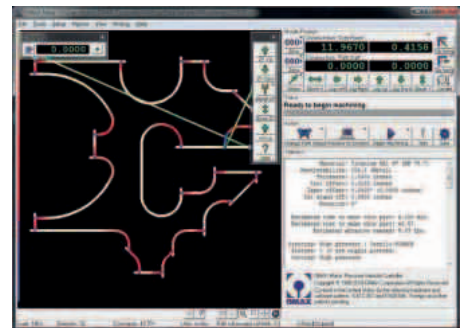

compared with the non-OMAX machines your competitors may have and, with free updates for the life of the machine, it's easy to keep systems fully updated for optimal cutting.

### UK Agent:

**Aquajet Machining Systems Ltd**

**Tel: 01257 248480**

**Email: sales@aquajet.co.uk**

**www.omax.com**

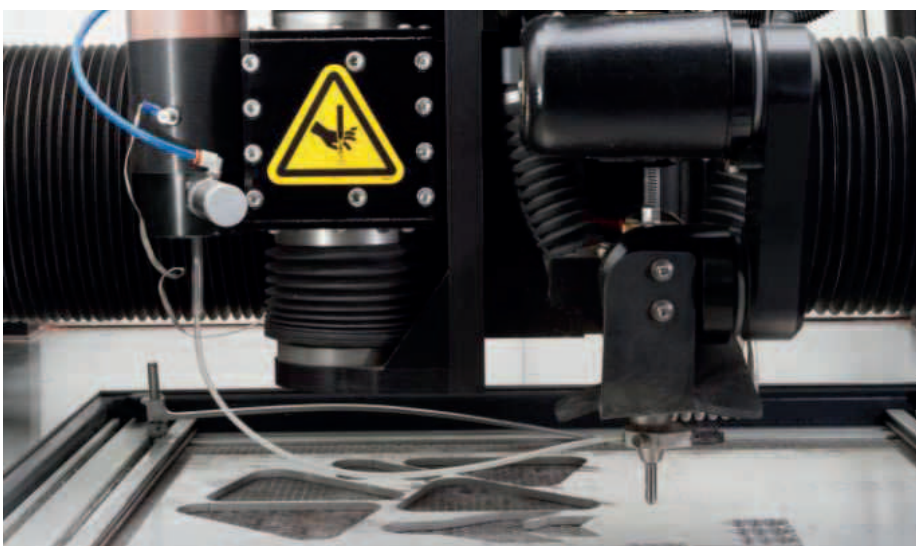



# New 5-axis cutting head to radically increase waterjet cutting efficiency

Following the recent introduction of a new corporate identity, AAG (XYZ Automation Group) has added an exclusive 5-axis cutting head to its WARDJet range of waterjet cutting systems. Called the Apex-60, this compact and fully integrated machine enhancement is said to be the most affordable and versatile of its kind currently available and to bring the benefits of advanced three-dimensional cutting technology to a wider range of industrial applications.

Key attributes of the Apex-60 include the ability to cut at angles of up to 60 degrees using a cutting force of 39N and at a maximum speed of 50.8 metres/minute which, according to AAG, sets the Apex-60 apart from any comparable 5-axis cutting head. It also greatly accelerates the speed and efficiency at which secondary finishing processes such as 60-degree cut bevels, weld preparation, grinding, chamfering and countersinking can be carried out, all of which invariably require additional machine

staff and thus increasing operational costs and machine downtime. With a Z-travel capability of 304.8 mm, the Apex-60 will process materials in the widest and thickest dimensions likely to be encountered, with full maximisation of the cutting envelope and no compromise on quality.

The Apex-60 will also accommodate the processing of a wider range of more complex materials. Typically, these include stainless steel and other non-ferrous metals, cast and wrought iron, various alloys like brass and bronze, aluminium sheet and aluminium composites, marble, ceramic, glass, fibreglass, high-density plastics and laminates and solid and composite rubber formulations. These are used variably in an equally diverse range of industries, including the general engineering, automotive, aerospace/aeronautical, electrical, metal/glass fabrication, plating/finishing and marine sectors.

The XYZ team believes for ongoing success it's crucial to keep in touch with its



clients. The company backs up this belief with sales and support offices in Canada, the United States, the UK, Poland and India, enabling it to directly interact with more than 90 percent of its customers.

For further information or to talk with an AAG technical engineer contact:

**XYZ Automation Group**  
**Tel: 01952 291600**  
**Email: [enquiries@axyz.com](mailto:enquiries@axyz.com)**  
**[www.axyz.co.uk](http://www.axyz.co.uk)**

# CAN'T CUT THIS?

**Cut any material and any shape with a single equipment**

Flow's waterjet cutting equipment performs a perfect cut on any material (wood, acrylic, plastic, armoured glass, marble, granite, stainless steel, carbon, aluminum, titanium, rubber, cork, nylon etc.) with excellent finishing, no tool change, just choose a new material from the software library.

With Flow water jet it is possible to cut any design, even the most complex ones with richness of details and in the most varied thicknesses and with great finishing.

Contact us and know the options that we have to meet your company

**Flow**  
SHAPE TECHNOLOGIES GROUP®

**Flow UK : [www.FlowWaterjet.com](http://www.FlowWaterjet.com)**  
**Unit 3 Canton House**  
**Wheatfield Way, Hinckley, LE10 1YG UK**  
**Office: +44 1455 895 300**

**Flow Europe**  
1988-2020  
First in Waterjet  
40 Years of Waterjet Technology, Innovation & Customer Commitment



## Go with the Flow - 40 years of waterjet cutting



Flow is a leader in ultra high-pressure waterjet, abrasive waterjet technology and complete systems for cutting. Founded in the early seventies in Kent, Washington in the US as a high-pressure pump manufacturer, today Flow technology is well known in many industries for precise two- and three-dimensional cuttings.

Flow's roots date back to the early 1970s, when former research and development scientists from Boeing founded Flow Research. The first technology commercialised by Flow Research was the use of an UHP waterjet as an industrial cutting tool. Soon after, it invented, patented and perfected the world's first abrasive waterjet system.

Since 1974, Flow has delivered over 13,000 waterjet and abrasive waterjet systems to customers in more than 100 countries.

Pump pressures of 4,000 and 6,000 bar produce waterjet velocities of approximately 1,100 m/sec. By means of adding an abrasive medium, abrasive waterjet technology, to the waterjet also hard materials such as metals, stone, glass or plastics can be cut easily. Material thicknesses of up to 250 mm are worked effortlessly. Here its versatility in the use of the most varied materials is particularly convincing. Flow Europe GmbH, founded in 1980 in Darmstadt, Germany, acts as the European Headquarters with its own branches in Italy, the UK, France, Czech Republic and Spain.

### 50 years waterjet cutting technology

Flow is a pioneer and absolute leader in waterjet technology. Already in 1971, the waterjet was applied for industrial purposes for the first time: to cut disposable baby diapers. It was very quickly recognised that the pump will always remain an important component of a smooth cutting process, however, the market demands complete cutting systems. Today the high-tech company offers innovative systems for a

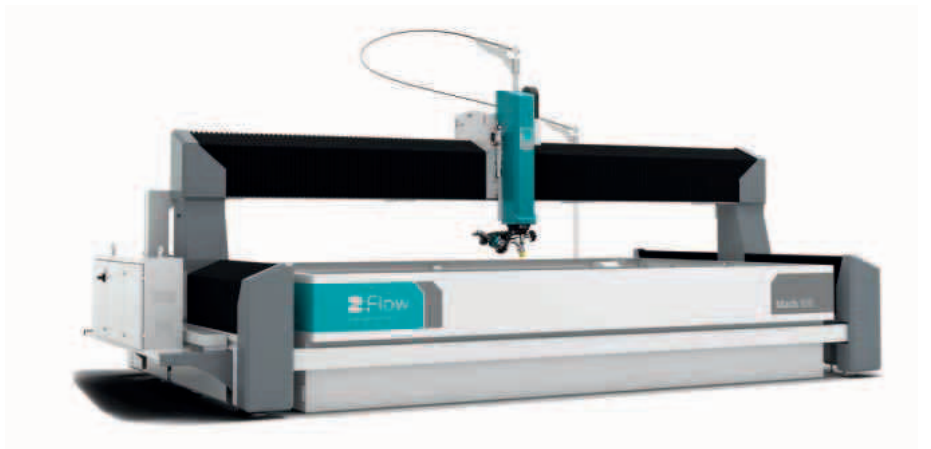
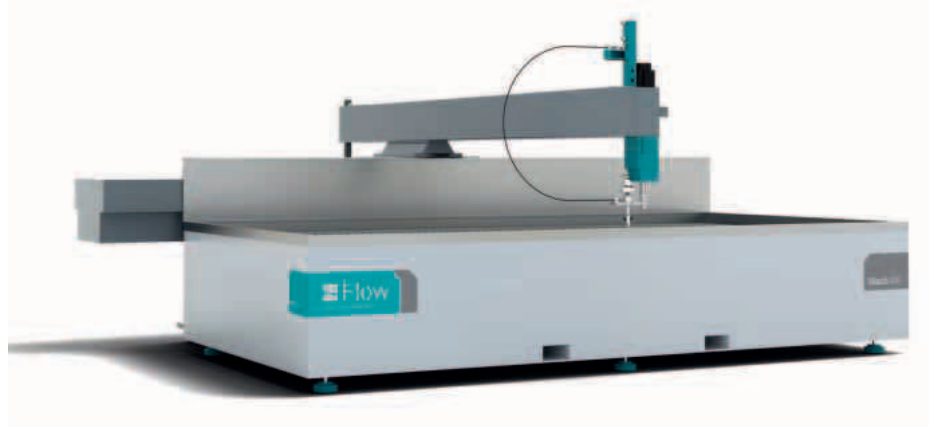

wide range of applications to its customers in the aerospace, automotive, paper, food, plastics metal, stone, and glass industries. Whereas classical separating methods such as sawing or flame/plasma/laser cutting often require a second working step, finishing, the waterjet performs the finishing directly.

### 40 years abrasive waterjet cutting

With the development of abrasive jet cutting by Flow, the special cutting head for abrasive waterjet cutting is registered for a

patent, the way was open to an even wider range of applications. By adding an abrasive to the waterjet, the cutting force is increased tremendously. Thus, high-quality cuts can be performed in nearly all materials. Metal, glass, stone and other hard materials can be worked precisely and environmentally friendly.

### 40 years Flow Europe

Flow Europe GmbH in Darmstadt was founded in 1980 as the FLOW Group's European Headquarters with own branch

offices in Italy, the UK, France, Czech Republic and Spain. Since then Flow Europe has grown and developed continuously. About 80 employees are working throughout Europe.

With the brand-new demonstration and training centre opened in France in 2019, with nearly 700 m<sup>2</sup> of floor space, the company has now taken a further step to present and test technology and products optimally. Here customers and interested parties can be advised and informed about the many and diverse applications. Customer-related test cuts on the most varied machines can be performed.

Since March 2020, Michael Eckart has managed the company in Darmstadt. At his side is a highly motivated, young management team for the areas of engineering, project management, production, sales, marketing, finance and administration.

### A strong back-up

Today the high-tech company Flow, part of SHAPE Technologies Group, is a leading system supplier for waterjet and abrasivejet cutting technology worldwide. The company, with much practical know-how, can work on ever-new customer applications. More than 700 employees worldwide create from the experience of over 13,000 delivered waterjet systems.

In the International Headquarters in the USA, research is conducted intensively. Approximately six to nine percent of sales are reinvested annually in research and development for the

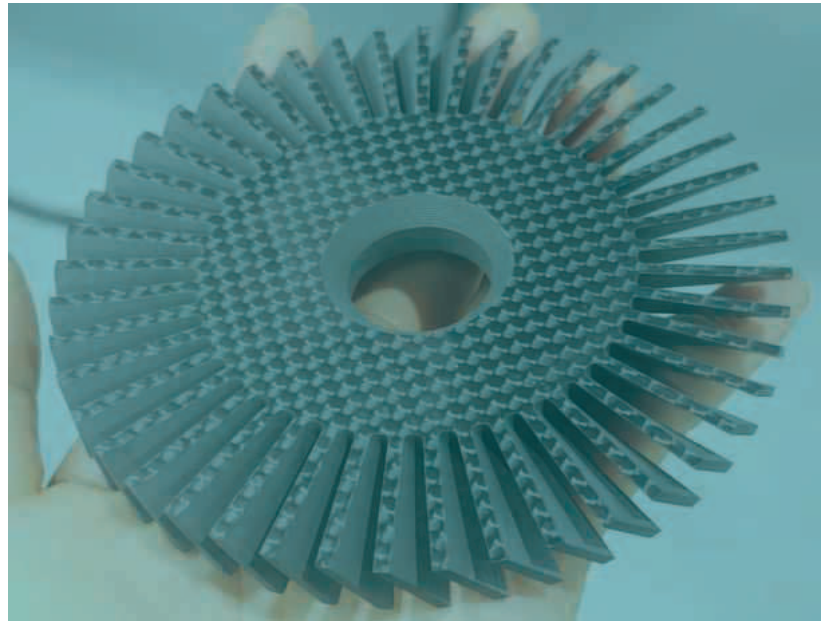

solutions of tomorrow. Currently it has access to a database of well over 10,000 cutting experiments carried out themselves with the most varied materials.

**Flow UK Ltd Tel: 01455 895300**

**Email: info-uk@flowcorp.com www.flowwaterjet.com**

**Passion for precision**

With over 30 years experience in waterjet cutting our passion for precision, development & quality is unparalleled.

We offer bespoke machine designs & with our market leading service & support are with you every step of the way. Let us help find the right solution for you. Call us on 01937 845 499.

Devoted to performance

**WJS**  
WATER JET SWEDEN

WJS UK Ltd, Moat House Square, Thorp Arch, Wetherby. [waterjetsweden.co.uk](http://waterjetsweden.co.uk)

**We think one cut ahead.**

Waterjet cutting system by StM. [stm.at](http://stm.at)

**StM**  
Waterjet solutions



# Fully automated laser productivity

A fully automated LVD laser cutting system at J.A. Harvey (Bassingham) Ltd / Harvey Fabrication in Lincoln is allowing the family-run company to maintain a stable pricing structure and, in some cases, reduce costs for its customers along with improving production lead times. It is aiding them in the current climate to compete for the larger contracts against fierce competition. The system includes a 10 kW Phoenix 4020 Fibre Laser integrated with twin storage towers, automated loading and unloading, two shuttle tables and an additional powered side table that can be moved in and out of the system for manual operation. The company also purchased LVD's CADMAN®-L laser programming software and CADMAN-JOB workflow management software.

The productivity of the system has allowed the company to condense 110 hours of laser cutting and 100 hours of plasma cutting into just 70 hours on the new machine. This has allowed it to cut costs by up to 20 percent on larger contracts.

This is the largest automation system to have been installed by LVD in the UK and the first since it acquired the Italian industrial automation specialist COMPAC S.r.l.

Harvey Fabrication was founded by the father of the current directors, Paul and Dave Harvey in 1973 and originally focused on work for the agricultural sector. It now employs more than 50 people in a 50,000 sq ft factory with facilities for laser, plasma and flame cutting, as well as punching,



bending, section bending, plate rolling, sawing, drilling and fabrication.

Director Paul Harvey says: "Our core business is fabrication, supplying fully fabricated parts and assemblies on a subcontract basis and we try to do as much as we can in-house to support our customer base."

It manufactures a lot of secondary steelwork components and structural fittings as well as structural steelwork and is CE marked to BS EN 1090 execution class 4.

With that breadth of customers, it is no surprise that Harvey Fabrication also works in a wide range of materials and thickness, from thin sheet up to heavy plate across low-carbon and high-strength steels, aluminium and stainless steel.

The company bought its first laser, a second-hand 4.5 kW CO<sub>2</sub> machine, in 2013. Up until then it had used outside subcontractors, but deliveries were often late, which affected Harvey's own customer service.



Work for the laser quickly grew by developing their existing customers and before long it was running 120 hours a week with one operator on a permanent night shift, so the company decided to think about investing in a new system.

It decided on the 10 kW LVD Phoenix laser because of its cutting capacity and the quality of cut that could be achieved with nitrogen as an assist gas and the fact that LVD were prepared to work together to find the correct solution. Thanks to this cutting capability, some work that was previously cut on the plasma machine and then drilled is now being done in a single operation on the laser.

"On structural steel, depending on the execution class, we can now put the holes in by laser," says Paul Harvey.

"Imagine you want to put a 90 mm hole through a 25 mm plate to a 0.15 mm tolerance for a linkage pin or a bush. Plasma will only cut to a mm tolerance, drilling it will take ten minutes, but if we use the laser it takes no time and gives the tolerance we need. It has speeded up production and guarantees the accuracy."

Paul Harvey says the original plan had been to just buy a laser rather than an automated system: "When you are a subcontractor you don't give much thought to automation, but we'd been running a standalone laser for five years, so I knew the





time that unloading took. So maybe it was worth automating that. Then I started thinking about the possibility of automated loading too."

The key point though was that any automation had to have a high degree of flexibility, running small manually loaded and unloaded batches and big fully automated runs on the same machine.

"One job might be to quickly produce six profiles from an offcut, but our next job might be to cut 50 sheets of 20 mm material," says Paul Harvey.

He looked at a lot of standard solutions, but nothing fitted what he was after, until he saw a picture of an LVD system with tower automation and realised that this could be the answer.

Paul Harvey adds: "LVD could offer a tailor-made solution to suit exactly what we needed."

The system now installed at Harvey Fabrication includes two storage towers with a total of 33 stations, each holding up to three tonnes of material. They are positioned along the factory wall with a loading station in between them. The Phoenix laser has two normal shuttle tables and a direct unload station at the side of the

machine where parts can be loaded or unloaded. Overhead cross rails connect the storage towers, the conventional shuttle tables and the unload station.

"We have effectively got three working tables. While we have two tables working in the machine we can be unloading to the other one and then we can take that table out and pick the parts off it by hand or forklift, or whatever we want to do," explains Paul Harvey.

This gives a high degree of flexibility for accommodating urgent and small-run jobs, while allowing the efficient use of heavy remnants.

The storage capacity of the automation system gives further flexibility, with a wide range of materials in store and ready for processing. This will also allow unmanned operation overnight. The final piece in the jigsaw is the CADMAN-JOB production planning software.

Paul Harvey concludes: "As well as managing the workflow to the laser, this will tell us our operating efficiency, how many cutting hours we have scheduled and how many hours we still have available.



"One of the biggest reasons for us making this investment was the cost-effectiveness, in terms of time savings, that you get from running a fibre laser with automation. It means you can increase the margin on a product without increasing the cost to the customer.

"The productivity is colossal. We have taken 110 hours from the old CO<sub>2</sub> laser and 100 hours off our plasma machines and condensed that into about 70 hours on the new system."

**LVD UK Ltd**  
**Tel: 01295 676800**  
**Email: [salesteam@lvd.uk.com](mailto:salesteam@lvd.uk.com)**  
**[www.lvdgroup.com](http://www.lvdgroup.com)**

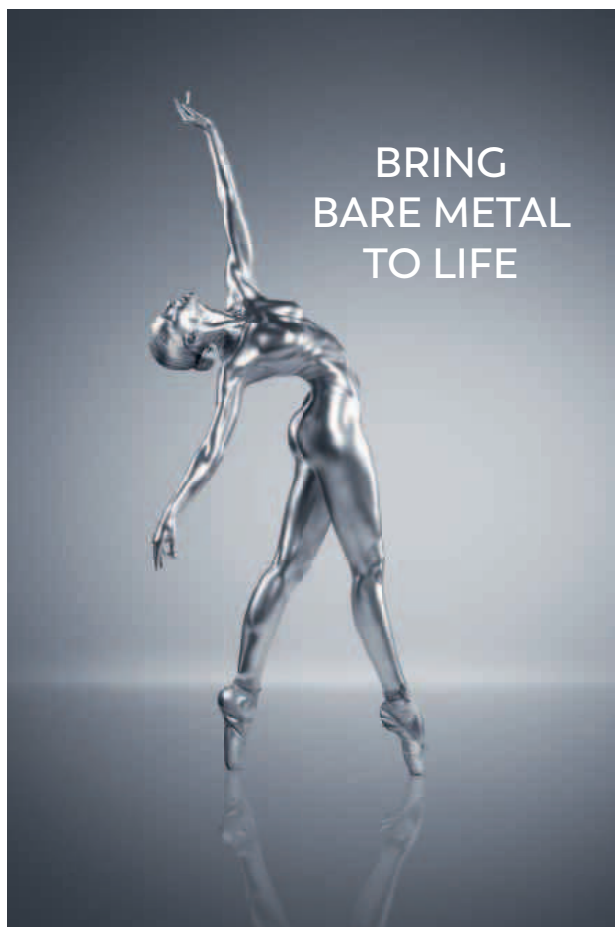

**BRING  
BARE METAL  
TO LIFE**

## DYNA-CELL PRESS BRAKE AUTOMATION

Fast and cost-efficient robotic bending

Dyna-Cell offers maximum productivity, bending small- to medium-sized parts with top precision. The unique combination of the electric-drive Dyna-Press Pro press brake, an agile Kuka robot and LVD's unique gripping technology makes this manufacturing cell a solid asset in your workshop.

- Optimum cost-benefit ratio
- Perfect match between press brake and robot for high performance
- Quick transfer from work preparation to production
- Unique gripper made by LVD for handling a wide part size range
- Unmanned or manned production

We help you bring bare metal to life: [lvdgroup.com](http://lvdgroup.com).



SHEET METALWORKING, OUR PASSION, YOUR SOLUTION

INTEGRATE

BEND

PUNCH

LASER

# Major European train builders invest in Powerstir Friction Stir Welding

Specially developed Powerstir Friction Stir Welding (FSW) machines from UK-based Precision Technologies Group (PTG), that incorporate a 30 m x 4 m moving gantry, could soon redefine the way in which Europe's leading manufacturers of railway rolling stock produce aluminium carriage bodies.

Manufacturers typically use a combination of TIG and MIG welding to create railway panel welds. However, as the Powerstir friction stir welding process provides far superior, high-strength joints, one leading European train builder already anticipates that using its newly purchased Powerstir FSW machine will lead to a reduction in the wall thickness of panels, with the potential for weight savings of as much as 30 percent. Thanks to the considerable gantry length of Powerstir rail sector machines, the business will also be able to weld some of its longest carriage panels in one single operation.

Since their launch, PTG's Powerstir gantry-type FSW machines have been used extensively in the production of railway carriage panels for some of the world's fastest trains. With a growing demand for lighter-weight aluminium carriage bodies across the wider rail industry, increasing numbers of European-based manufacturers are now placing orders for PTG's British-built Powerstir machines. "We are delighted that leading European rolling stock builders are recognising the considerable advantages that Powerstir friction stir welding offers and look forward to working alongside them as they begin using our technologies," comments PTG regional sales director, Mark Curran.

### Longest single FSW railway panel welds

Developed by Precision Technologies Group specifically for use in the railway industry, Powerstir gantry machines are renowned for their ability to produce particularly long friction stir welds. For example, a Powerstir machine is used to create what are believed to be the longest single FSW railway panel welds in China at over 15 m in length.

### Proven weld quality

PTG is widely considered to be a leader in



the development of FSW technologies for transport applications. Over recent years, Powerstir friction stir welders have found favour with companies from across the automotive, aviation and high-speed rail sectors. The Powerstir FSW process provides a clean, highly aesthetic alternative to traditional welding. It delivers proven weld quality, excellent mechanical properties, virtually no porosity and the opportunity for reduced wall thickness in many applications. Reduced wall thickness provides important opportunities for saving weight, while virtually no porosity helps minimise the ingress of moisture over time, an important attribute, especially where railway carriages are operated in harsh environments. With welding speeds of up to 3,000 mm/min, the Powerstir process is typically more than three times faster than conventional automated welding techniques.

### High-strength joints that are virtually defect free

Friction stir welding combines frictional heat with precisely controlled forging pressure to produce extremely high-strength joints that are virtually defect free. Due to the very low welding temperature, mechanical distortion is practically eliminated, with minimal Heat Affected Zone (HAZ) and an excellent surface finish. Friction stir welding transforms the parent metal from a solid to a plasticised state. This occurs during a process that involves mechanically stirring the materials to be joined together, to form a high-integrity, full-penetration welded

joint. The Powerstir FSW process is effective on flat plates, cylindrical components and even on parts of irregular thickness. Although used primarily for joining aluminium, powerstir friction stir welding can also be applied to magnesium, copper, titanium and steel alloys.

### The first name in precision

Incorporating the brands of Holroyd, PTG, Powerstir Friction Stir Welding and Holroyd Precision Rotors, PTG has established itself at the forefront of high-precision machine tool design, build and supply for specialised applications. The range includes advanced machine tools for the production of complex helical components, such as compressor rotors, pump screws and high-accuracy gears and Powerstir machine tools for friction stir welding advanced alloys used in transport applications. With production facilities in the UK, USA and China, Holroyd Precision Rotors manufactures the special purpose, ultra-precision helical components used in a wide range of industries, including refrigeration, air-conditioning, gas and vacuum pumping, industrial air handling, aerospace, medical equipment, motion control, power transmission, power generation, oil & gas, fluid transfer and high-end automotive. PTG also provides advanced technical consulting services.

### PTG

Tel: 01706 526 590

Email: [neil.jones@ptgltd.com](mailto:neil.jones@ptgltd.com)

[www.ptgltd.com](http://www.ptgltd.com)

# 123insight INFO Exchange

## The new online way to evaluate MRP

Regular sessions

90 minutes

Free to attend

**See what a manufacturing system *should*  
be doing for your business.**

At 123 Insight we've always done things differently. Due to the coronavirus outbreak, we've placed our usual manufacturing software Evaluation Workshops on hold, instead creating a new online event.

The 123insight online INFO Exchange is a free to attend manufacturing companies' online interaction from which you will gain a better understanding of what MRP can do for your business. This regularly held group online session lasts for around 90 minutes, during which you will see software demonstrated and get to understand the 123insight difference. There's a Q&A session at the end, so you'll also get to hear from other like-minded companies, often asking questions that you may not have even considered!

Alternatively, register to get instant access to our online Demo Movies, broken down by job role, which explain what 123insight will do for each department in your business.

***Book to attend at [123insight.com](https://www.123insight.com)***

**Advanced  
Simplicity®**

123 Insight Limited

[info@123insight.com](mailto:info@123insight.com) [www.123insight.com](http://www.123insight.com)





# Drilling In XXL-Format

With the KUB Centron you can create large holes  
High length-diameter ratio with safety and economy.

Find out more at:

[cutting.tools/en/kub-centron](http://cutting.tools/en/kub-centron)

TEAM CUTTING TOOLS



KOMET



klenk

CERATIZIT is a high-tech engineering group  
specialising in cutting tools and hard material  
solutions.

**Tooling the Future**

[www.ceratizit.com](http://www.ceratizit.com)